

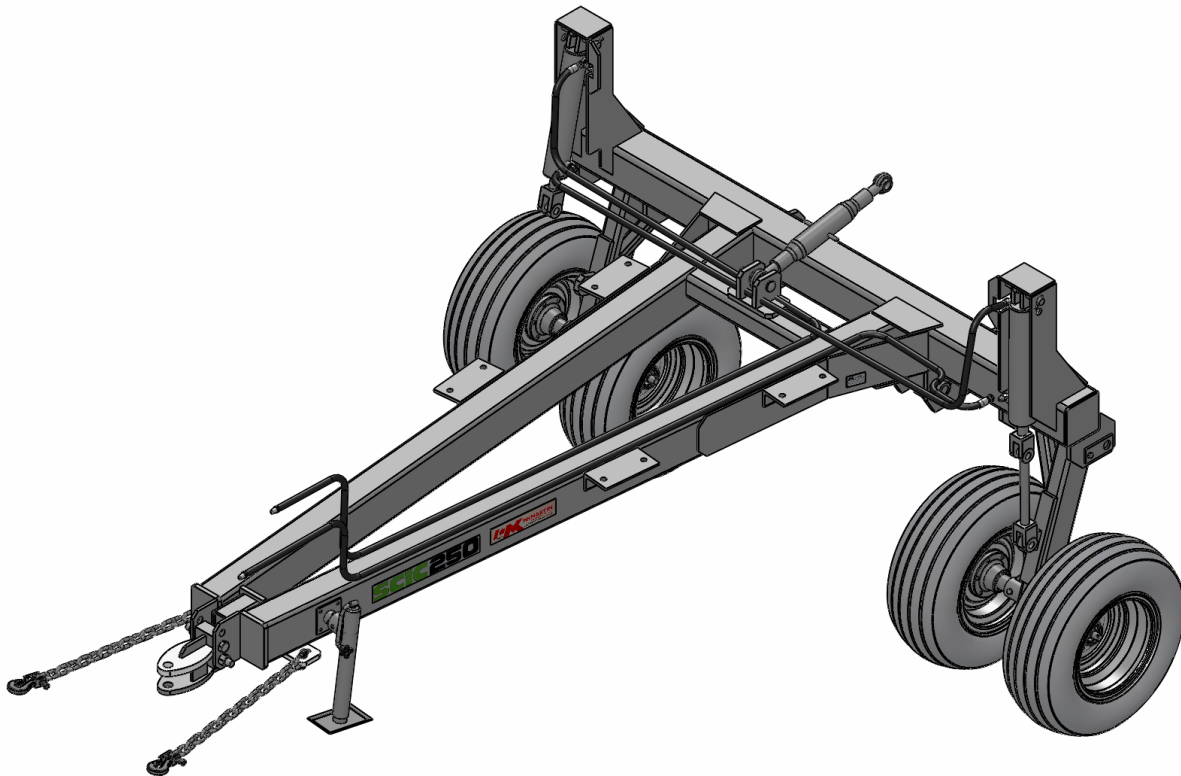

## Tool Caddy

# SCIC250

## Owner/Operator Manual



M K Martin Enterprise Inc  
3950 Steffler Rd Elmira On. Ca N3B 2Z3

Tel: 519-664-2752  
Toll Free: 1-855-664-2752  
Fax: 519-664-3695  
e-mail: sales@mkmartin.ca  
www.mkmartin.ca



## Warranty and Limitations of Liability

All equipment is sold subject to mutual agreement that it is warranted at M K Martin Inc. (Hereafter called the company). to be free of any defects of material and workmanship. The company shall not be liable for special, indirect consequential damage of any kind under this contract or otherwise. The company's liability shall be limited exclusively to replacement or repair without charge at it's factory or elsewhere, at it's discretion, any materials or defects, which become apparent within one year form the date of purchase. In no event shall M K Martin Enterprise Inc. be liable special, direct, or incidental or consequential damages of any kind. The purchaser by acceptance of the equipment will assume all liability for damage which may result from use or misuse by the employees or others. The purchaser shall maintain and service the equipment as recommended in the Operator's Manual.

This warranty does not cover **Rental/Commercial or Rental** use of the equipment. This equipment is rated as agricultural.

For **Rental/Commercial or Industrial** use, Warranty is for defective material and workmanship for a period of 90 days from the date of purchase.

Warranty is null and void unless the Warranty Registration form has been completed and on file at

M K Martin Enterprise Inc  
3950 Steffler Rd  
Elmira On Ca N3B 2Z3

For your Record

**Purchase Date** \_\_\_\_\_

**Model #** \_\_\_\_\_

**Serial #** \_\_\_\_\_

Please contact your retailer

**Manufactured by**  
**M K Martin Enterprise Inc**  
**3950 Steffler Rd**  
**Elmira On Ca N3B 2Z3**  
Tel: (519)-664-2752  
(855)-664-2752  
Fax: (519)-664-3695  
E-mail: sales@mkmartin.ca

www.mkmartin.ca

## Table of Contents

- Registration
- Safety
- Decal Location
- Operation
- Parts
- Bolt Torque
- Maintenance

# Warranty Registration

Please Cut and Return to M K Martin Enterprise Inc

Fold And Tape here    *Do not tape all edges or use staples*

*Fold Here*

Postage  
Stamp

**M K Martin Enterprise Inc**  
3950 Steffler Rd  
Elmira ON CA N3B 2Z3

**M K Martin Enterprise Inc**  
3950 Steffler Rd  
Elmira On Ca N3B 2Z3

Purchaser's warranty protection equipment is valid only when this completed form or a copy of

~~WRPWO~~ ~~WRPWE~~

~~WRPWR~~ ~~WRPWO~~

~~WRPWE~~

Date of delivery to purchaser -----

Type of Equipment -----

Model # ----- Serial # -----

**Retailer's Signature Indicates**

- ~~WRPWR~~
- ~~WRPWR~~
- ~~WRPWR~~
- Warranty was explained to purchaser
- ~~WRPWR~~

**Retailer**

Signature -----

Company -----

Address -----

**Purchaser's signature indicates**

- ~~WRPWR~~
- Received operator's manual
- Clearly understands conditions of warranty
- Received instructions of safe and proper operation of equipment

**Purchaser**

Signature -----

Company -----

Mailing address -----

City ----- Prov/State ----- Postal Code/Zip -----

Available phone number -----

Warranty is valid only when it has been received by manufacturer at address

## Safety

**Take Note!** This safety symbol is found throughout this manual to call your attention to instructions involving yourself and others working around the machine.

- **Failure to follow these instructions can result in injury or death!**



This symbol means

-- **Attention!**

-- **Become Alert!**

-- **Your Safety is involved!**

Signal words are used in this manual.

**Caution:** Indicate a potential hazardous situation that may result in injury.

**Warning:** Indicates a hazard situation that could result in serious injury or death.

**Danger:** Indicates a hazardous situation that needs to be avoided. It is you the operator that needs to be aware of these dangers.

If you have any questions not answered in this manual please contact you dealer or

M K Martin Enterprise Inc  
3950 Steffler Rd  
Elmira On Ca N3B 2Z3

Tel: 519-664-2752  
1-855-664-2752  
Fax: 519-664-3695  
e-mail sales@mkmartin.ca

[www.mkmartin.ca](http://www.mkmartin.ca)



## Safety -- It,s in your interest!



### Caution:

When attaching the Tool Caddy ensure all pins and locks are secure before driving away!

When unhitching the Tool Caddy, Lower the row units to the ground and position the jack, before removing the drawbar pin. With the row unit raised, the hitch end may be too light to balance the load on the rear. This may cause the front end to raise up unexpectedly and cause injury.



### The Tool Caddy has **high-pressure hydraulic lines!**

Before using check for leaks, abrasions and kinks.

Wear safety glasses and gloves when checking for leaks. Use a piece of wood or cardboard to find leaks, as a fine stream of oil may not be visible but can still penetrate the skin and enter into the blood stream!



**If skin is penetrated with an oil stream, seek medical attention immediately!**

Use safety chain at all times!



# Decal Location

Manufactures Decal



Serial Plate



Model Number

High Pressure

## **Operating**

The SCIC 250 Tool Caddy attaches to the Cat #3 implement and raises up and down by raising and lowering the wheels. The cylinders are re-phasing cylinders, to keep the frame level at all times.

The implement is attached to two lower hitch plates and the top link.

Working height is controlled with the Tractor hydraulics.

# Notes

## Parts

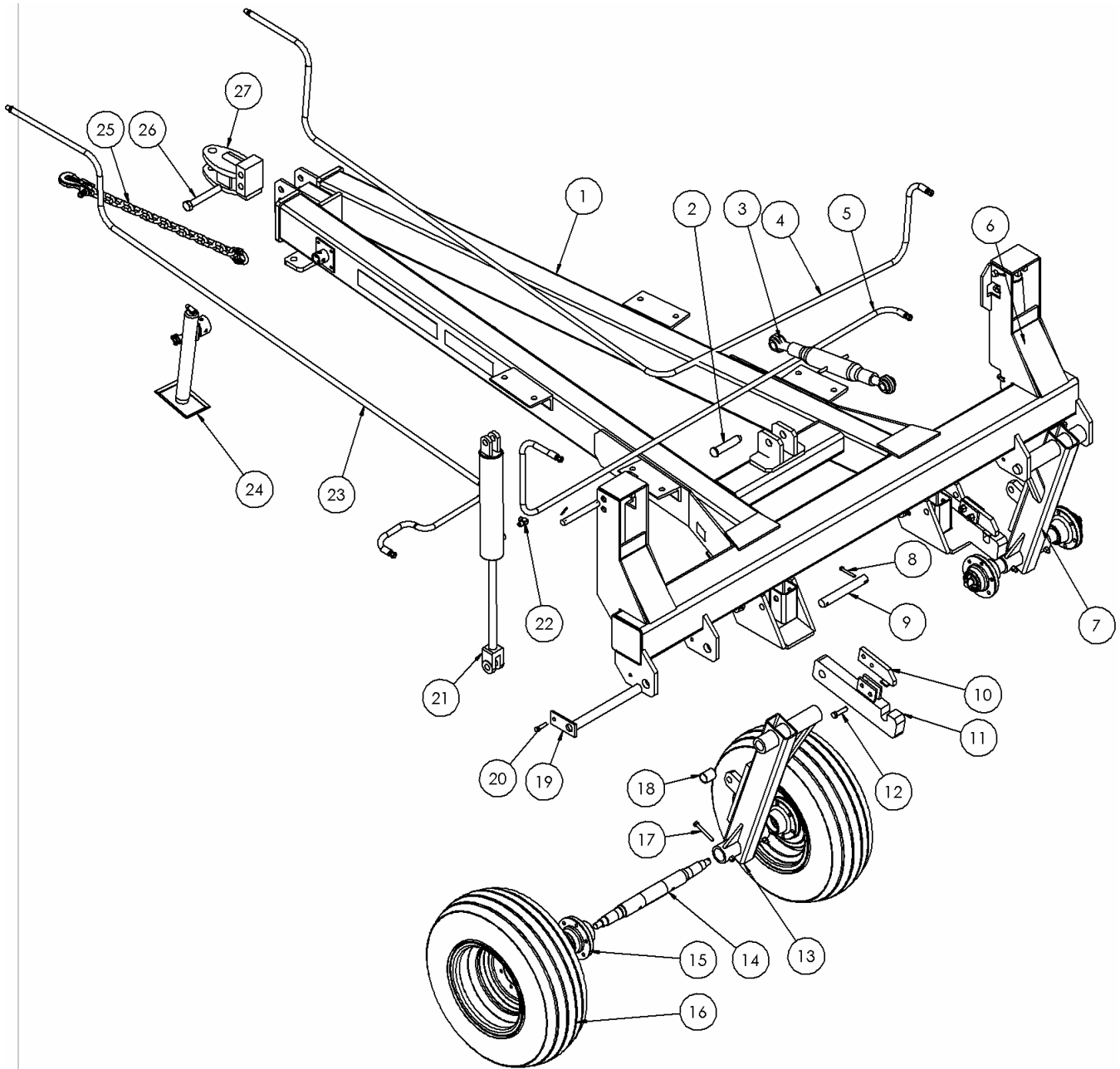

Item #	Part #	Description	Qty
1	24398	Main Frame	1
2	wal387507	Cat #3 Top Link Pin	1
3	wal387612	Cat #3 Top Link	1
4	23557	Long Hydraulic Line	1
5	23556	Short Interconnect Hose	1
6	cyl32WP16-125	3 1/4x16 re-pha cylinder	1
7	24400	Right Wheel Stem	1
8	OL	Bolt 3/8x3 c/w ln	4
9	22542	Hitch Lock Pin	2
10	22548	Hitch Latch	2
11	22549	Hitch Bar	2

12			
12	OL	Bolt 5/8x2 1/2 c/w ln	4
13	22526	Left Wheel Stem	1
14	23055	Spindle	2
15	hub6000	6000 Hub	4
16	OL	11.5L15 Wheel	4
17	OL	Bolt 1/2x4 c/w ln	4
18	brgbrz171520	Bushing	4
19	24396	Wheel Stem Pivot Pin	2
20	OL	Bolt 1/2x2 c/w ln	2
21	cyl35WP16-125	3 1/2x16 re-phase Cylinder	1
22	681-0808	Hydraulic Fitting 90° elbow	4
23	23558	Short Hydraulic Line	1
24	CFSIJ5015T	Jack	1
25	wal651045	Safety Chain	2
26	OL	Bolt #8 1-12x7 nf c/w ln	2
27	22233	Hitch	1

**Note:**

**OL = Obtain Locally**

**c/w = complete with**

**ln - Locknut**

## Bolt Torque

As used on this equipment

Bolt torque table shown below gives torque values for the various bolts used. This chart is for non-lubricated threads. Replace with the same strength bolt.

Torque Specifications. Torque values are identified by their head markings

Diameter	SAE 2		SAE 5		SAE 8	
	Lb-ft	N.m	Lb-ft	N.m	Lb-ft	N.m
1/4	6	(8)	9	(12)	12	(17)
5/16	10	(13)	19	(25)	27	(36)
3/8	20	(27)	33	(45)	45	(63)
7/16	30	(41)	53	(72)	75	(100)
1/2	45	(61)	80	(110)	115	(155)
5/8	95	(128)	160	(215)	220	(305)
3/4	165	(225)	290	(390)	400	(540)
1	225	(345)	630	(850)	970	(1320)

Allen head cap screws are similar to SAE 8 quality.

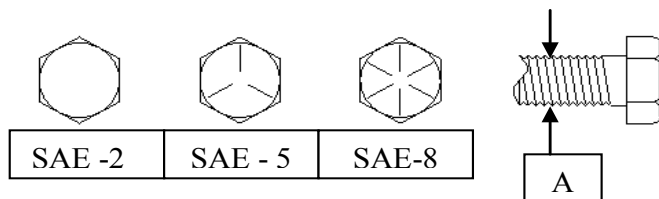

These torques are for a reference only. Not all these sizes and grades are necessarily used in this machine. Bolts that are used as a pivot or hinge have to be used with a locknut, therefore only tighten enough to secure the bolt and still allowing the part to rotate freely.

## Maintenance

- This equipment is designed for low maintenance.
- 
- After 1 hour of use inspect all nuts and bolts, ensure they are all tight.
- 
- After 5 hours repeat the inspection
- 
- After the first day of use check all nuts and bolts again, inspect all hydraulic lines and fitting for leaks and signs of rubbing or kinking. Rectify any leaks, rubbing or kinking.
- 
- Repair and/or replace any worn parts.
- 
- Inspect and repack wheel bearings annually.