

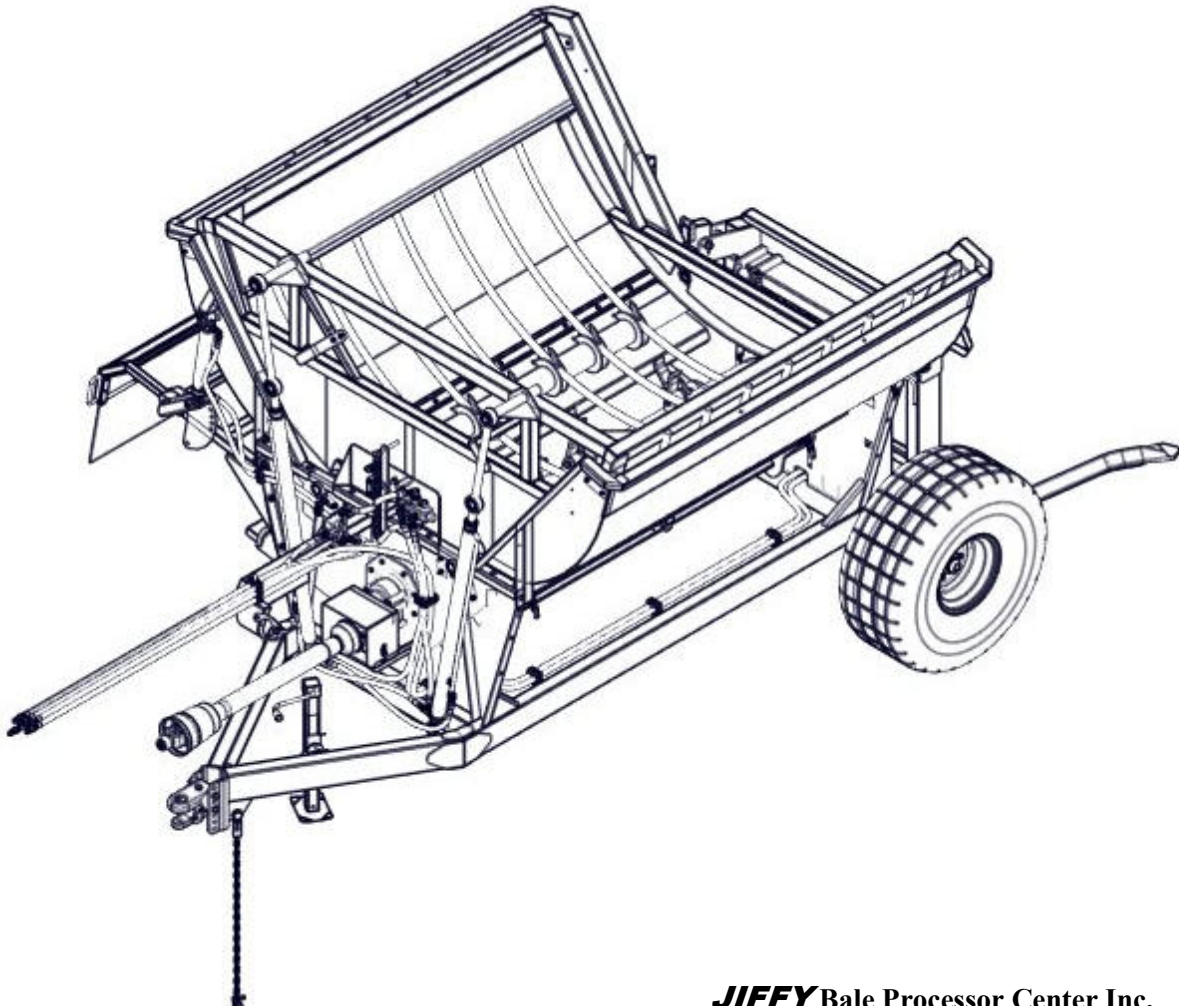

BALE PROCESSOR

Operator's & Parts Manual
Model No. J93800-0010.01



JIFFY Bale Processor Center Inc.

R.R. #4

Lacombe, Alberta, Canada

T4L 2N4

Phone: (403) 784-3518

Fax : (403) 784-2060

Email : JIFFYBale Proces-

sor@JIFFYBale Processor.com

www.JIFFYBale Processor.com

TABLE OF CONTENTS

TABLE OF CONTENTS	1.1
INTRODUCTION	1.3
JIFFY WARRANTY POLICY	1.4
BALE PROCESSOR SERIAL NUMBER LOCATION	1.5
2 SAFETY	2.1
2.1 GENERAL SAFETY.....	2.2
2.2 OPERATING SAFETY	2.3
2.3 MAINTENANCE SAFETY	2.3
2.4 HYDRAULIC SAFETY	2.4
2.5 STORAGE SAFETY	2.4
2.6 SAFETY DECALS	2.4
2.7 SAFETY SHIELD PLACEMENT	2.5
2.8 SIGN-OFF FORM	2.6
3 DECAL LOCATIONS	3.1
3.1 SAFETY DECAL LOCATIONS.....	3.1
3.2 INFORMATION DECAL LOCATIONS.....	3.3
4 OPERATION	4.1
4.1 TO THE NEW OPERATOR OR OWNER.....	4.1
4.2 PRE-OPERATIONAL CHECKLIST	4.1
4.3 BREAK-IN.....	4.2
4.4 CONTROLS	4.3
4.4.1 DEFLECTOR.....	4.3
4.4.2 CRADLE TILT SYSTEM.....	4.4
4.5 ATTACHING/UNHOOKING	4.5
4.6 OPERATING THE BALE PROCESSOR.....	4.7
4.6.1. LOADING AND UNLOADING.....	4.7
4.6.2 STOPPING	4.9
4.6.3 ROTOR CLEANING.....	4.10
4.6.4 CRADLE TILT	4.10
4.6.5 FLAIL BACKSLAP.....	4.11
4.6.6. BALE TINES.....	4.11
4.6.7. OPERATING TIPS	4.11
4.7 TRANSPORTING.....	4.12
4.8 STORAGE	4.13
5 SERVICE AND MAINTENANCE	5.1
5.1 SERVICING RECORD	5.1
5.2 SERVICING INTERVALS.....	5.2
5.3 GEARBOX	5.5
5.4 MAINTENANCE & ADJUSTMENTS.....	5.7
5.4.1 ROCKING BALE CRADLE SYSTEM.....	5.7
5.4.2 STROKE	5.7
5.4.3 SPEED	5.7
5.4.4 CRADLE SHIFTING VALVE.....	5.8
5.4.5 FLAIL BACKSLAP	5.9
5.4.6 ROTOR MAINTENANCE	5.9
5.4.7 PTO SAFETY SHIELD.....	5.9
5.4.8 SHEAR BOLTS	5.10
5.4.9 HITCH.....	5.10
5.4.10 BALE LOADING FORKS.....	5.10

TABLE OF CONTENTS

6	PDI SETUP	6.1
7	TRANSPORTATION	7.1
8	STORAGE	8.1
	8.1 PLACING IN STORAGE	8.1
	8.2 REMOVING FROM STORAGE & PRE-SEASON PREPARATION.....	8.1
9	TROUBLESHOOTING GUIDE	9.1
10	SPECIFICATIONS	10.1
	10.1 GENERAL SPECIFICATIONS	10.1
	10.2 TIRE SPECIFICATIONS	10.1
	10.3 BOLT TORQUE SPECIFICATIONS.....	10.1
	10.4 OVERALL DIMENSIONS	10.3
11	PARTS	11.1
	11.1 FRAME ASSEMBLY.....	11.1
	11.1.1 HITCH ASSEMBLY	11.3
	11.1.2 WHEEL AND HUB ASSEMBLY	11.4
	11.1.3 LIGHT KIT ASSEMBLY	11.5
	11.1.4 HUB ASSEMBLY	11.6
	11.2 BALE CRADLE ASSEMBLY	11.7
	11.3 CRADLE ROLLER ASSEMBLY	11.8
	11.4 DRIVE AND ROTOR ASSEMBLY	11.9
	11.5 DEFLECTOR ASSEMBLY.....	11.11
	11.6 VALVE SHIFTER	11.13
	11.7 LOAD FRAME ASSEMBLY	11.15
	11.8 CRADLE HYDRAULICS	11.17
	11.9 LIFT CYLINDER HYDRAULICS.....	11.19
	11.10 DEFLECTOR HYDRAULIC.....	11.20
12	NOTES SHEET	12.1

INTRODUCTION

Congratulations on your decision to purchase a JIFFY Bale Processor. This machine has been designed to provide you with the highest standards of quality, reliability and durability. This manual has been prepared to familiarize you with the operation and maintenance of your Bale Processor. We urge you to read this publication carefully and refer to it extensively for correct operating procedure.

The JIFFY Bale Processor is designed to give the operator a maximum capacity and working surface through the use of a large diameter roll. Added to this is a convenient method of roll removal, and a new process of roll adjustment, giving the operator infinite control of feed quality. The unit is constructed in a solid manner, giving you value for your dollar and a Bale Processor that will last.

This manual includes a Warranty Policy, a Safety Section, and Lubrication and Maintenance Schedule. We urge you to read through this information carefully. This will help to ensure the safe and trouble-free operation of your Bale Processor. All information, illustrations and specifications in this manual are based on the latest product information available. We, the manufacturer, reserve the right to make any changes at any time without prior notice.

LIMITED WARRANTY

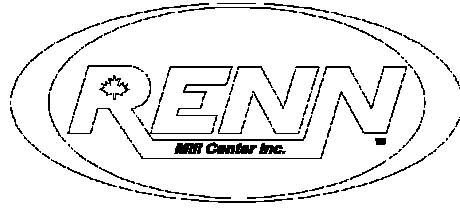

• NEW EQUIPMENT WARRANTY

Subject to the limitations and exclusions set out herein, JIFFY Bale Processor Center Inc. ("JIFFY") warrants that if any component or part of a machine manufactured by JIFFY proves to be defective in material or workmanship within

1. (1) year from the delivery date of the original sale to a purchaser who purchases the equipment for their own farming operation use; OR
2. (90) days from the delivery date of the original sale to any other purchaser.

JIFFY will at JIFFY's option either repair or replace the defective part without charge. No payments will be made in lieu of repair to the machine. This limited warranty may be enforced by the first purchaser or first consumer user; all subsequent purchasers acquire the product "as is" without any benefit of this limited warranty.

• LIMITATIONS AND EXCLUSIONS

This limited warranty by JIFFY does not extend to or include:

1. New tires - installed on the equipment which are subject to a separate warranty by the tire manufacturer—see warranty sheet included with your owners manual. All warranty claims must be submitted to the tire manufacturer for approval and payment.
2. Used tires
3. Drive Belts
4. Drive Chains

This limited warranty covers defects in material and workmanship in the parts manufactured by JIFFY except:

1. Damage resulting from accident, misuse, abuse, neglect or from other than normal and ordinary use of the equipment.
2. Damage resulting from failure to clean or use the product in accordance with the manufacturer's instructions.
3. JIFFY reserves the manufacturer's right to determine the responsibility for damage as detailed in 1 and 2 above.

JIFFY shall, as to each defect, be released from all obligations and liabilities under this warranty if;

1. The equipment shall have been operated with any accessory, equipment, component or part not manufactured by JIFFY or not approved for use by JIFFY.
2. The equipment shall have been repaired, altered or modified without JIFFY's approval or if the equipment shall have been operated subsequent to its involvement in an accident or breakdown unless the purchaser furnishes reasonable evidence that such repair, modification or operation subsequent to its involvement in an accident or breakdown was not the cause of the defect;
3. If the purchaser or consumer does not, within 30 days from the date of discovery of the defect, return the defective machine, accessory, equipment component or part at the purchaser's or users expense to an authorized dealer, purchaser shall be responsible for submission of reasonable evidence or proof of date of discovery of subsequent defect.

• WARRANTY AND PARTS REPLACED BY WARRANTY

JIFFY further warrants that if any genuine JIFFY part or component utilized by authorized JIFFY dealers in accordance with this limited warranty proves to be defective in material or workmanship within 90 days of such utilization, JIFFY will, at JIFFY's option either repair or replace the defective part without charge. Purchaser shall be responsible for any shipping charges including freight to and

• WHAT YOU MUST DO TO ENFORCE THIS WARRANTY

1. Warranty services must be performed by a dealer authorized by JIFFY. The purchaser must, at the purchaser's expense, deliver, mail or ship the defective part to any duly authorized dealer in the purchasers area. If the purchaser is unable to locate a dealer in the purchaser's area, please contact JIFFY. JIFFY will either refer you to an authorized dealer or instruct you where to return the product. Do not return the product to JIFFY, without JIFFY's prior authorization
2. Purchaser must pay any postage, shipping charges, insurance costs, freight and other expenses to and from the place where the warranty work is done or performed if required to return equipment or any component or part to an authorized dealer or as directed by JIFFY. Purchaser shall be obligated to pay any premium payable for overtime labour if overtime is incurred as a result of a request by the purchaser.

• UNAPPROVED SERVICE OR MODIFICATION

All obligations of JIFFY under this warranty shall be terminated:

1. If service is performed by someone other than a dealer authorized by JIFFY or,
2. If equipment is altered or modified in ways not approved by JIFFY.

Accidents and normal maintenance

This warranty covers only defective material and workmanship. It does not cover depreciation or damage caused by normal wear, accident, improper maintenance, improper protection in storage or improper use. The cost of normal maintenance and replacement of service items, oil filters, cutting parts, tires, bearings, chains, sprockets or brake parts shall be paid for by the purchaser.

• NO REPRESENTATION OR IMPLIED WARRANTY

1. Where permitted by law, neither JIFFY nor any company affiliated with it makes any warranties, representation or promises expressed or implied as to the quality or performance of its products other than those set forth above.
2. JIFFY makes no warranty of merchantability or fitness for a particular purpose.

• IMPROVEMENTS OR CHANGES

JIFFY reserves the right to make improvements or changes in design and specifications at any time without incurring any obligation to owners of previously sold units.

• WARRANTY CLAIM PROCEDURE

Warranty Claim Form must be delivered to JIFFY within 60 days after the warranty work was performed. Defective parts must be held for inspection for 90 days after the work was performed. JIFFY may request that parts be returned to the JIFFY factory for inspection. If approved, JIFFY will issue a credit within 60 days of receiving the warranty claim.

• ACKNOWLEDGEMENT REQUIRED

JIFFY shall have no obligation under this warranty unless the "Warranty Registration" included with your owners manual signed by purchaser and dealer is delivered to JIFFY within 30 days from the date of sale.

IMPORTANT NOTICE

To activate warranty coverage, the owner / dealer must complete the Warranty Registration form that can be found online and return to JIFFY Bale Processor Center Inc. R.R. 4, Lacombe, Alberta, Canada, T4L 2N4 within 30 days of re-

BALE PROCESSOR SERIAL NUMBER LOCATION

The serial number plate is located on the inside face of the back panel of the top hopper, on the driver's side of the machine.

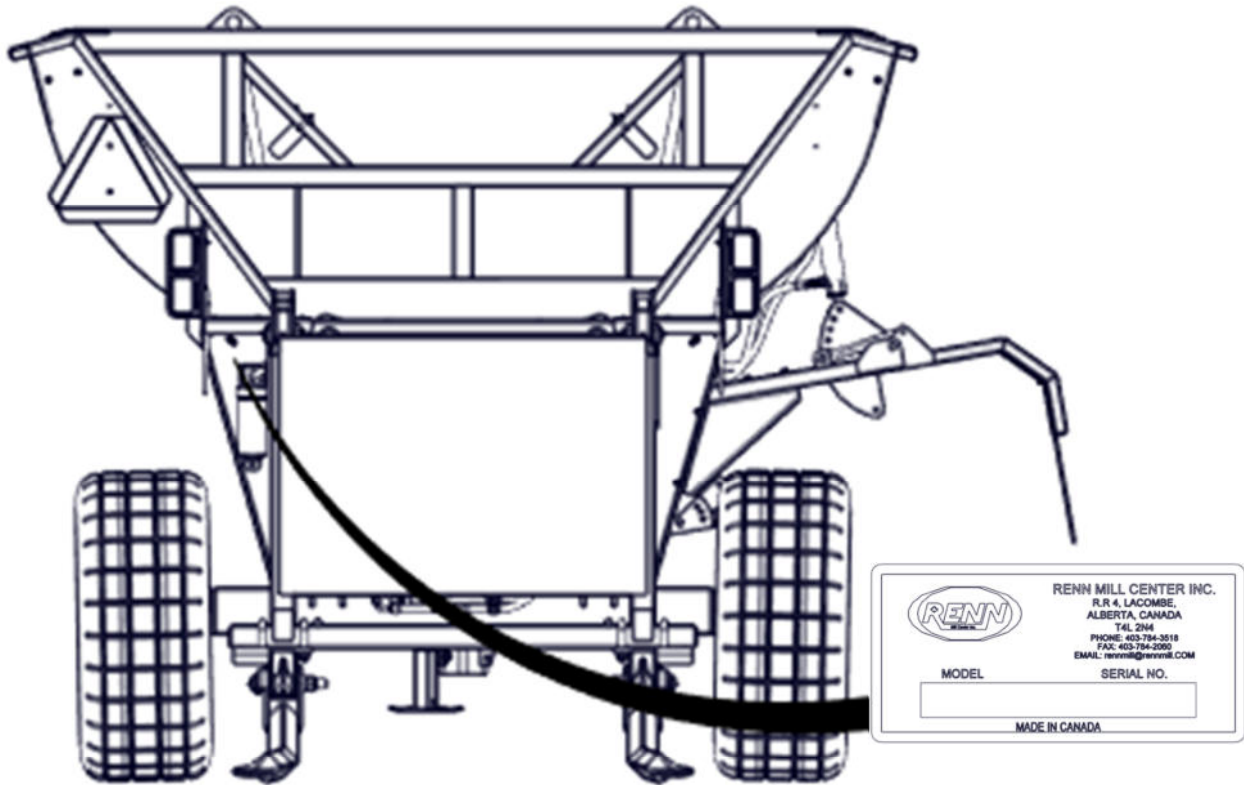

IMPORTANT: For fast, correct service when ordering parts, provide the following information to your local JIFFY Dealer:

- 1) The model number
- 2) The serial number

This information is essential when ordering parts for your JIFFY Bale Processor.

2 SAFETY

Safety Alert Symbol

This Safety Alert symbol means

**ATTENTION!
BE ALERT!
YOUR SAFETY IS
INVOLVED!**

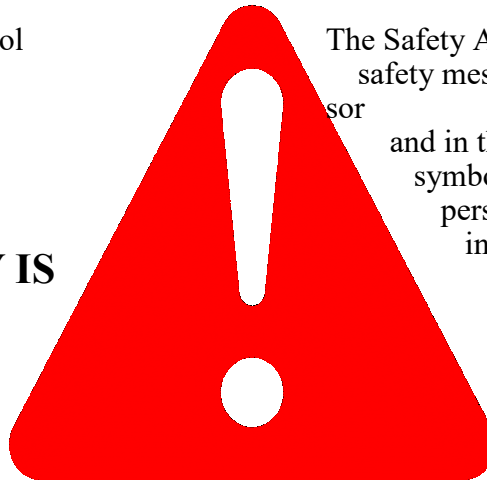

The Safety Alert symbol identifies important safety messages on the JIFFY Bale Processor

and in the manual. When you see this symbol, be alert to the possibility of personal injury or death. Follow the instructions in the safety message.

Why is SAFETY important to you?

3 Big Reasons

Accidents Disable and Kill

Accidents Cost

Accidents Can Be Avoided

SIGNAL WORDS:

Note the use of the signal words **DANGER**, **WARNING**, and **CAUTION** with the safety messages. The appropriate signal word for each message has been selected using the following guidelines:

DANGER -

Indicates an imminently hazardous situation that, if not avoided, will result in death or serious injury. This signal word is to be limited to the most extreme situations, typically for machine components that, for functional purposes, cannot be guarded.

WARNING -

Indicates a potentially hazardous situation that, if not avoided, could result in death or serious injury, and includes hazards that are exposed when guards are removed. It may also be used to alert against unsafe practices.

CAUTION -

Indicates a potentially hazardous situation that, if not avoided, may result in minor or moderate injury. It may also be used to alert against unsafe practices.

2 SAFETY



You are responsible for the SAFE operation and maintenance of your JIFFY Bale Processor. YOU must ensure that you and anyone else who is going to operate, maintain or work around the Bale Processor is familiar with the operating and maintenance procedures and related SAFETY information contained in this manual. This manual will take you step-by-step through your working day and will alert you to all good safety practices that should be adhered to while operating the Bale Processor.

Remember, YOU are the key to safety. Good safety practices not only protect you but also the people around you. Make these practices a working part of your safety program. Be certain that EVERYONE operating this equipment is familiar with the recommended operating and maintenance procedures and follows all the safety precautions. Most accidents can be prevented. Do not risk injury or death by ignoring good safety practices.

- Bale Processor owners must give operating instructions to operators or employees before allowing them to operate the Bale Processor, and at least annually thereafter per OSHA regulation 1928.57.
- The most important safety device on this equipment is a SAFE operator. It is the operator's responsibility to read and understand ALL safety and operating instructions in the manual and to follow them. All accidents can be avoided.
- A person who has not read and understood all operating and safety instructions is not qualified to operate the machine. An untrained operator exposes himself and bystanders to possible serious injury or death.
- Do not modify the equipment in any way. Unauthorized modification may impair the function and/or safety and could affect the life of the equipment.
- Think SAFETY! Work SAFELY!

2.1 General Safety

1. Only trained, competent persons should operate the Bale Processor. An untrained operator is not qualified to operate the machine.
2. Have a first-aid kit available for use, should the need arise, and know how to use it.
3. Have a fire extinguisher available for use, should the need arise, and know how to use it.
4. Wear appropriate protective gear. This list includes but is not limited to:
 - A hard hat
 - Protective shoes with slip resistant soles
 - Protective goggles
 - Hearing protection
5. Review safety related items with all personnel annually.
6. Place all controls in neutral, stop the engine, set the parking brake, remove the ignition key, wait for all moving parts to stop and disengage the PTO before servicing, adjusting, repairing or unplugging.

2 SAFETY



2.2 Operating Safety

1. Read and understand the Operator's Manual and all safety signs before using.
2. Install and secure all guards and shields before starting or operating.
3. Keep hands, feet, hair and clothing away from all moving and/or rotating parts.
4. Do not allow riders on the Bale Processor or tractor during operation or transportation.
5. Clear the area of all bystanders, especially children, before starting.
6. Be aware of overhead power lines at all times.
7. Attach any necessary flags and signs to Bale Processor before transporting.
8. Attach securely to the towing unit using a hardened pin with a retainer and a safety chain. The pin should be the maximum allowable size possible.
9. The Bale Processor is designed to process baled cereal grain commodities. It is not suggested to use the Bale Processor for other materials without receiving consent from the factory to do so. Failure to heed this warning will result in forfeiture of warranty.
10. Do not exceed a safe travelling speed during transportation.
11. Use a light kit on the Bale Processor to transport.
12. Ensure that adequate lighting is available when operating at night.
13. Use caution when using the machine on uneven terrain.
14. Always check behind you when backing up. The Bale Processor may block parts of your view.
15. Never unhook the Bale Processor while it is in use.
16. If applicable, make sure that all components are tight and that hoses, fittings and couplings are in good condition before pressurizing the hydraulic system.
17. Review safety instructions annually.

2.3 Maintenance Safety

1. Place all controls in neutral, stop the engine, set the parking brake, remove the ignition key, wait for all moving parts to stop and disengage the PTO before servicing, adjusting, repairing or unplugging.
2. Perform a lock out tag out (LOTO) procedure if required.
3. Relieve the pressure from the hydraulic system before servicing or disconnecting from the tractor.
4. Place stands or blocks under the frame before working beneath the machine or when changing tires.
5. Only use tools, jacks and hoists appropriate for the job.
6. Install and secure all guards and shields before resuming operation.

2 SAFETY



2.4 Hydraulic Safety

1. Always place all tractor hydraulic controls in neutral before dismounting.
2. Make sure that all components in the hydraulic system are kept in good condition and replace any worn, cut, abraded, flattened or crimped hoses.
3. Wear proper hand and eye protection when searching for a high pressure hydraulic leak. Use a piece of wood or cardboard as a shield instead of hands to isolate and identify a leak.
4. If injured, seek medical attention immediately. Serious infection or reaction can develop from hydraulic fluid piercing the skin.
5. Before pressurizing the system, make sure that all components are tight and that hoses, fittings and couplings are in good condition.

2.5 Storage Safety

1. Store unit in an area away from human activity.
2. Do not permit children to play on or around the stored Bale Processor.

2.6 Safety Decals

1. Keep safety decals clean and legible at all times.
2. Replace safety decals that are missing or have become illegible.
3. Replaced parts that previously displayed a safety decal should display the same decal.
4. Safety decals are available through your authorized JIFFY Dealer.

2 SAFETY



2.7 Safety Shield Placement

After servicing or maintenance, these shields should be back in place.

PTO Cover & Gear Box Shield

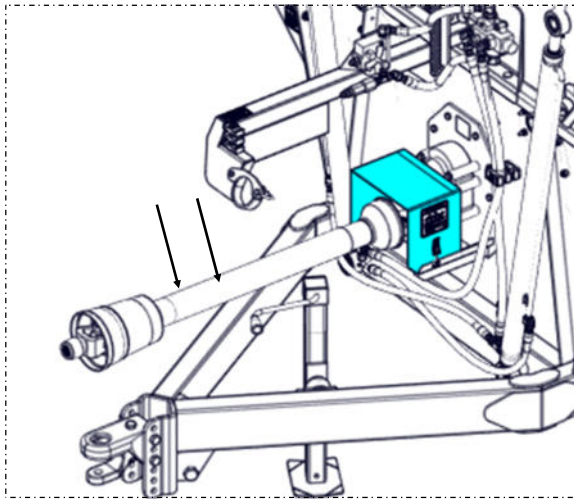

Shredder Access door

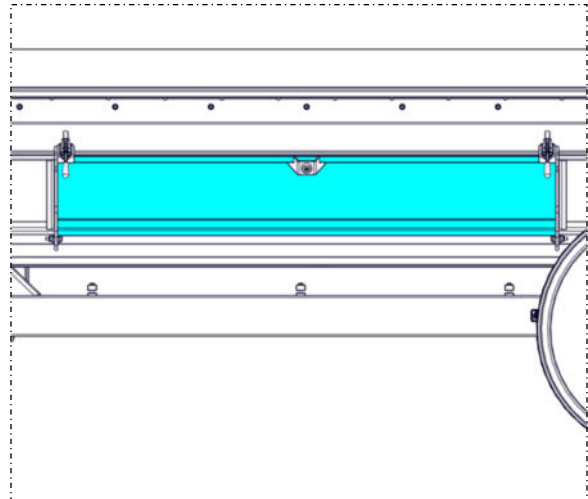

Shaft Guard

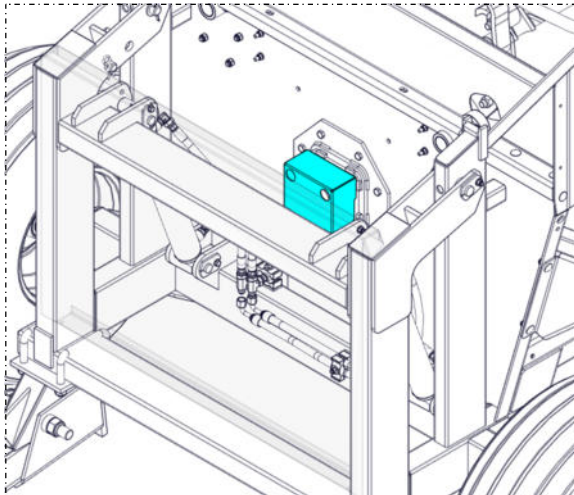

2 SAFETY



2.8 Sign-off Form

Anyone operating and/or maintaining the Bale Processor must read and clearly understand ALL Safety, Operating, and Maintenance information presented in this manual.

Do not operate or allow anyone else to operate this equipment until such information has been reviewed. Review this information annually, before the season start-up.

Make these periodic reviews of SAFETY and OPERATION a standard practice for all of your equipment. We feel that an untrained operator is unqualified to operate this machine. A sign-off sheet is provided for your record keeping to show that all personnel who will be working with the equipment have read and understood the information in the Operator's Manual and have been instructed in the operation of the equipment.

Sign-off Form

<i>DATE</i>	<i>EMPLOYEE SIGNATURE</i>	<i>EMPLOYER SIGNATURE</i>

**THIS PAGE INTENTIONALLY LEFT
BLANK**

3 DECAL LOCATIONS

3.1 Safety Decal Locations

The types of safety decals and locations on the equipment are shown in the following illustrations. Good safety requires that you familiarize yourself with the various safety decals, the type of warning and the area, or particular function related to that area, that requires your SAFETY AWARENESS.

- THINK SAFETY!!, WORK SAFELY!!



148000-0105



148900-0044



148900-0043



148900-0042



148900-0046



148900-0083

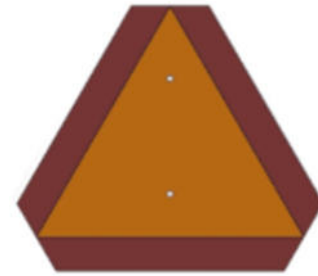

147000-0004



147000-0001



147000-0002



148900-0049

REMEMBER - If safety decals have been damaged, removed, or become illegible, or if parts have been replaced and do not contain safety decals where there were some previously, new decals must be applied. New safety decals are available from your authorized dealer.

3 DECAL LOCATIONS

3.1 Safety Decal Locations

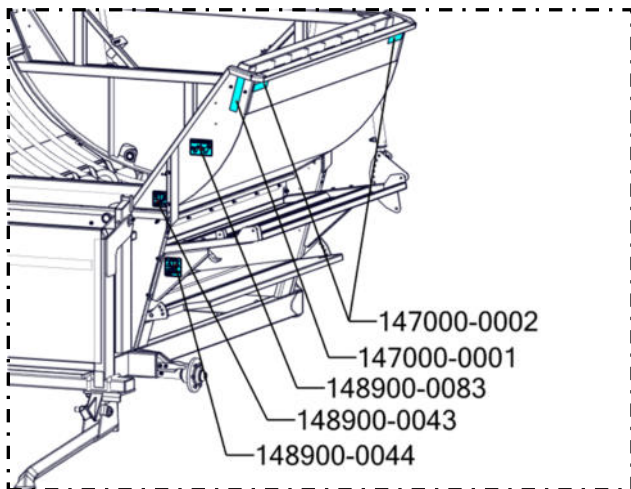
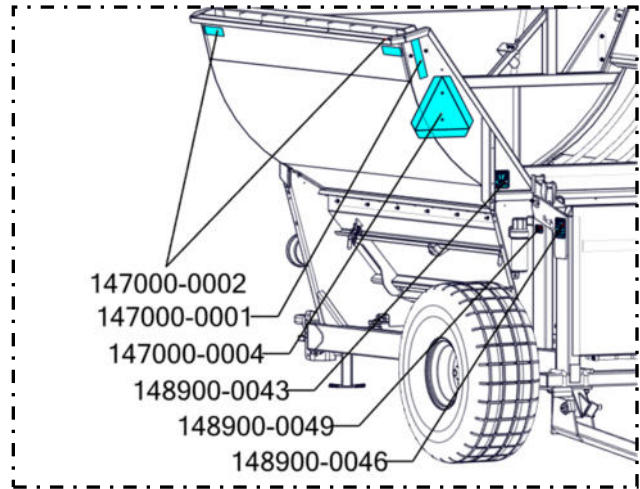
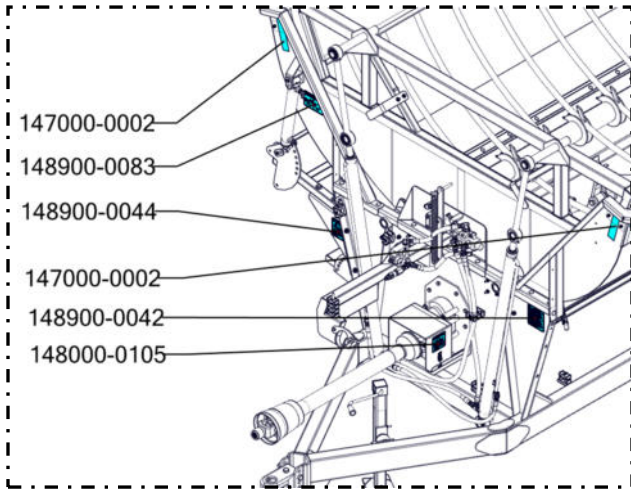

3 DECAL LOCATIONS

3.2 Information Decal Locations

The types of informational and operational decals and locations on the equipment are shown in the following illustrations. Good operation requires that you familiarize yourself with the various operational decals, the type of warning and the area, or particular function related to that area, that requires your AWARENESS.

- THINK SAFETY!!, WORK SAFELY!!



148900-0045

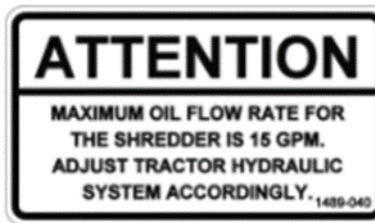

148900-0040

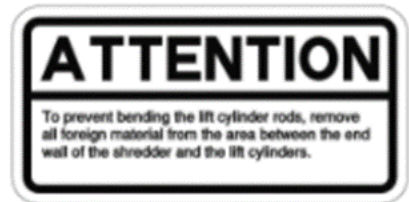

148900-0047



148100-0100



148900-0092



148900-0091



148700-0050



148900-0093



148800-0200



148900-0048



148000-0012

3 DECAL LOCATIONS

3.2 Information Decal Locations

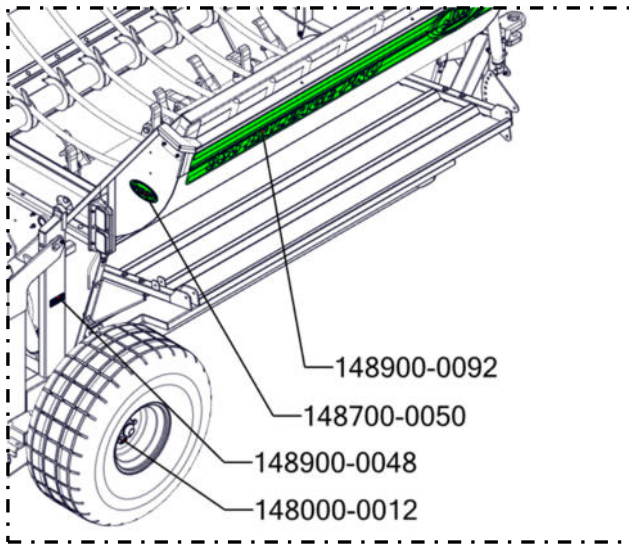
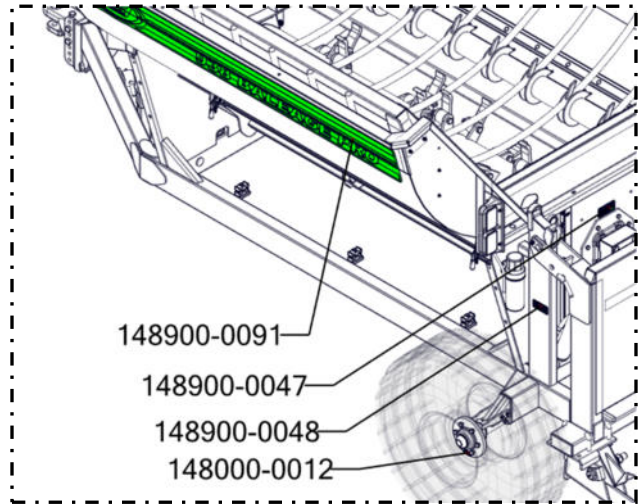
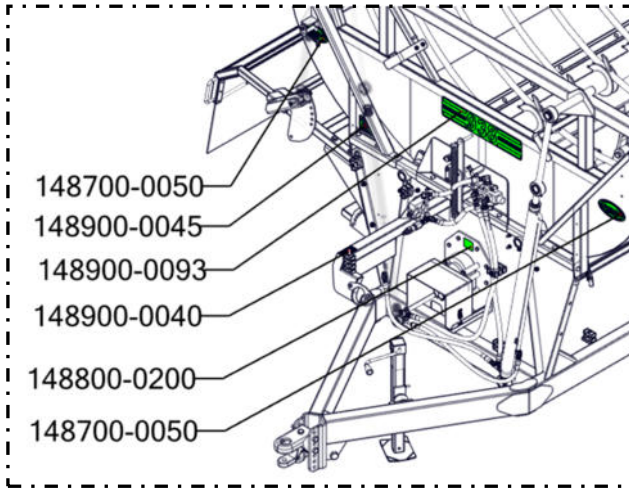

4 OPERATION

4.1 To the New Operator or Owner

The JIFFY Bale Processor is designed to process round or square bales and place the material in a row or spread it over the ground. Be familiar with all operating and safety procedures before starting.

In addition to the design and configuration of equipment, hazard control and accident prevention are dependent upon the awareness, concern, and prudence of personnel involved in the operation, transportation, maintenance and storage of equipment or in the use and maintenance of facilities.

It is the responsibility of the owner or operator to read this manual and to train all other operators before they start working with the machine. Follow all safety instructions exactly. Safety is everyone's business. By following recommended procedures, a safe working environment is provided for the operator, bystanders and the area around the work site. Untrained operators are not qualified to operate the machine.

Many features incorporated into this machine are the result of suggestions made by customers like you. Read this manual carefully to learn how to operate the machine safely and efficiently. By following the operating instructions in conjunction with a good maintenance program, your Bale Processor will provide you with many years of trouble-free service.

For more information, please refer to Section 2.3 & Section 5 for further maintenance directions.

4.2 Pre-Operational Checklist

The efficient and safe operation of the JIFFY Bale Processor requires that each operator read and understand the operating procedures and all related safety precautions outlined in this section. A pre-operational checklist is provided for the operator. It is important for both personal safety and maintaining the good mechanical condition of the Bale Processor that this checklist be followed.

Before operating the Bale Processor, and each time thereafter, the following areas should be checked:

1. Inspect the machine if it is the start of the season.
2. Lubricate the machine per the schedule outlined in the Maintenance Section (section 5).
3. Be sure that the machine is properly attached to the tractor. Be sure that a mechanical retainer is installed through the drawbar pin and the safety chain is installed.
4. Adjust the hitch position to make the Bale Processor level with the tractor.
5. Inspect all hydraulic lines, fittings and couplers.
6. Check all bearing locking collars to ensure that they are tight on the shafts and in good condition. Check that all set screws on the bearing collars are tight. Check that all bearing mounting hardware is secure.
7. Make sure all safety shields are properly installed.

4 OPERATION

4.3 Break-In

Although there are no operational restrictions on the Bale Processor when used for the first time, it is recommended that the following mechanical items be checked.

A. Before First Start Up:

1. Attach the Bale Processor to the tractor.
2. Cycle the lift frame and the bale cradle several times to fully charge the hydraulic cylinders with oil.
3. Top up the tractor oil reservoir if required.
4. Check the gearbox for any signs of leakage and check the gearbox oil level (Should be visible at the top of the oil plug).

B. After operating for 1/2 hour:

1. Re-torque all wheel bolts.
2. Re-torque all other fasteners and hardware.
3. Disconnect the PTO driveline and turn the rotor by hand. Be sure that it turns freely.
4. Check the rotor and flails. Remove all entangled material.
5. Check that no hoses are pinched, rubbing, bent, or crimped. Re-align as required.
6. Check for oil leaks. Repair or stop any leaks before continuing.
7. Lubricate all grease fittings.
8. Check gearbox for signs of leakage or wear.

C. After operating for 5 hours and 10 hours:

1. Re-torque all wheel bolts, fasteners, and hardware.
2. Check hydraulic hose routing.
3. Check that rotor turns freely.
4. Check that all flails move freely. Remove all entangled material.
5. Check the gearbox for signs of leakage or wear.
6. Follow the normal servicing and maintenance schedule as defined in section 5.

4 OPERATION

4.4 Controls

4.4.1 Deflector:

The discharge deflector is equipped with a lock pin system to set the deflector position. Retract the lock pin and move the discharge deflector to its desired position. Secure by inserting the lock pin into the frame anchor hole.

An optional hydraulic or electric position kit is available to position the deflector from inside the cab. Contact your dealer for more information.

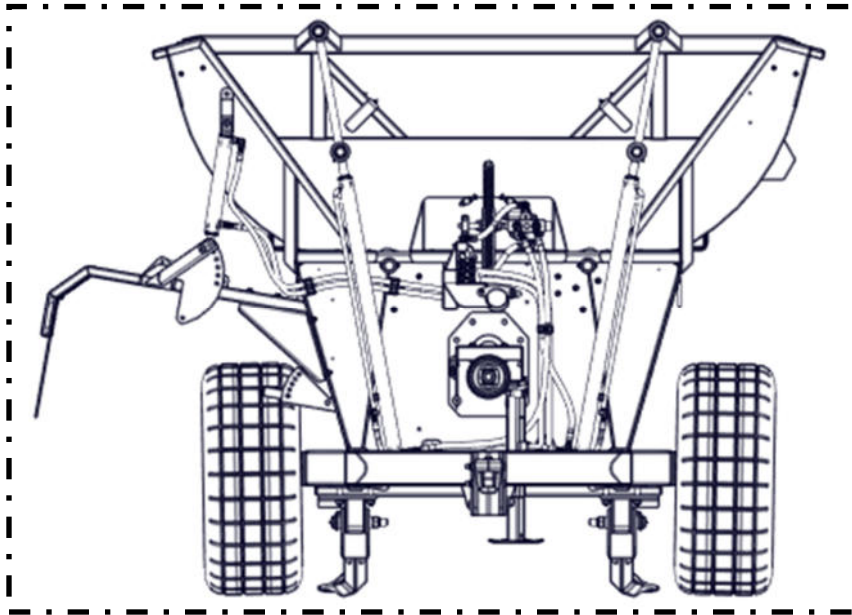

Windrowing Position

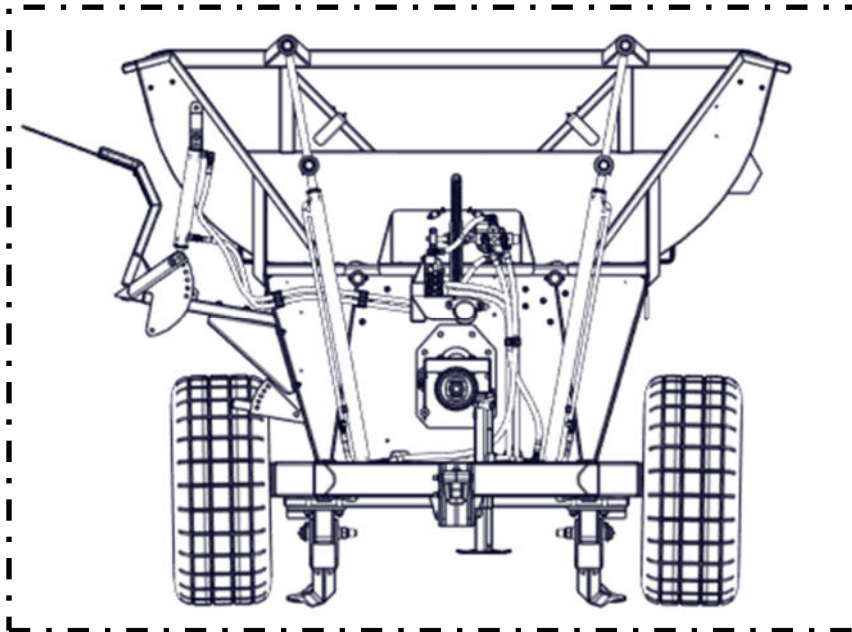

Spreading Position

4 OPERATION

4.4.2 Cradle Tilt System:

The Processor is designed with a cradle inside the frame that tilts or rocks from side to side and moves the bale across the flails/rotor to prevent bridging. It is a simple self-actuating system that is adjustable for speed and stroke to accommodate any type of bale or material.

a. Speed:

The system is designed with a standard flow divider to change and set the system speed. Set at 5 for maximum speed. Move toward 0 to decrease the speed. Normally it should take 10 to 12 seconds to complete one cycle of the cradle.

b. Stroke:

Use the sliding brackets on the cradle frame to set the range of the stroke.

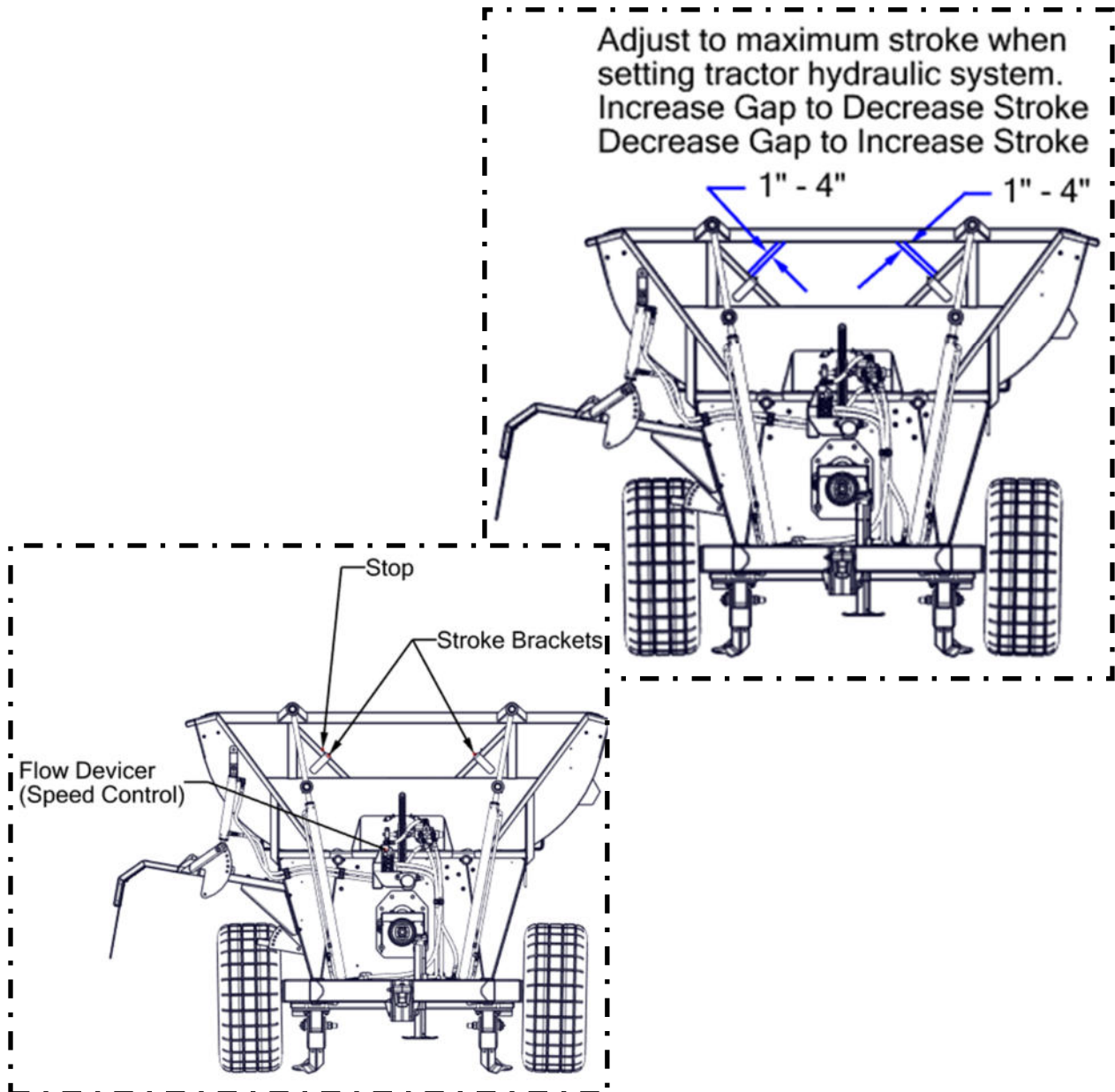

4 OPERATION

4.5 Lower Deflector working (Optional)

1. For processing into a windrow, set the deflector in-line with floor pan. This is the lowest hole on the angle adjuster frame which would result in lower exit speed and least amount of dust for windrowing.

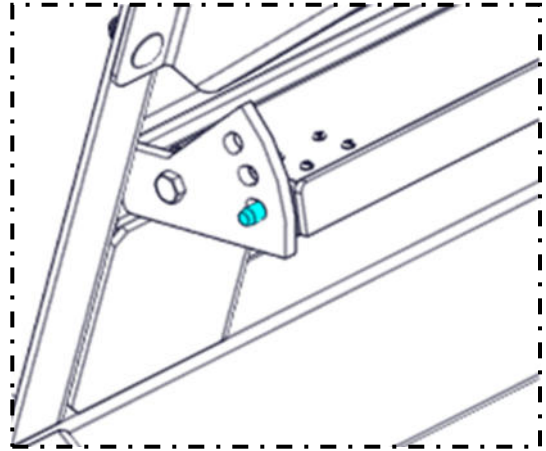

2. You can use the second slotted position when you are straw bedding or into a high bunk application. This position creates more straw throw.

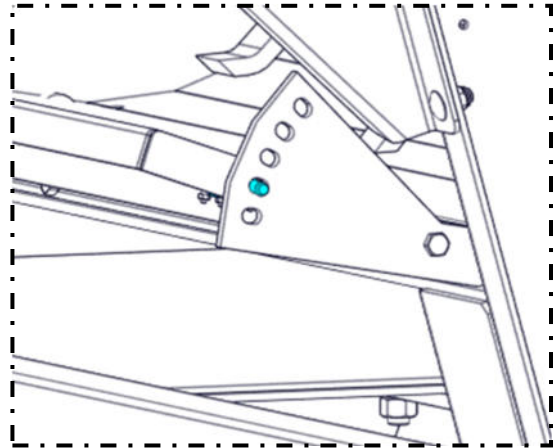

3. To produce a more even bed of straw, the pan can be twisted by forcing the end with the five holes to a lower slotted hole and the other end to the second slot which would result in varying exit speed along the length of the outlet, throwing longer on the narrowed end, throwing shorter on the more open end.

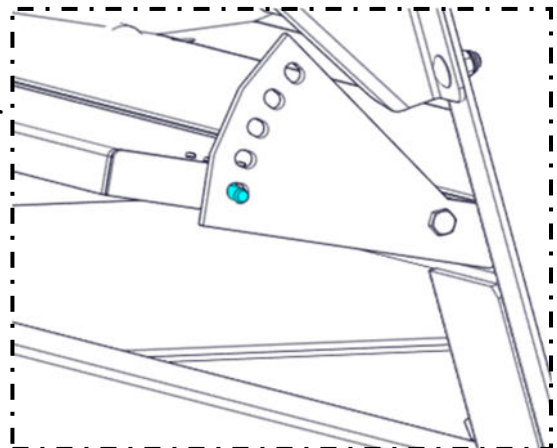

4 OPERATION

4.6 Attaching/Unhooking

The drawbar of the Bale Shredder is equipped with a two piece clevis style hitch. If the tractor is equipped with a clevis hitch, the clevis portion of the Bale Shredder must be removed to prevent binding when operating on uneven terrain.

Check hitch and clevis bolts on a weekly basis to make sure that they are properly tightened.

The machine should always be parked on a level, dry area that is free of debris and foreign objects.

Follow this procedure when attaching:

1. Clear the area of bystanders and remove foreign objects from the machine and working area.
2. Adjust the length of the drawbar to give the appropriate dimension between the PTO shaft and the drawbar pin hole. (Refer to Tractor Operator's Manual)
3. Use the jack to raise or lower the hitch to align with the drawbar.
4. Make sure there is enough room to back the tractor up to the hitch point.
5. Start the tractor and slowly back it up to the hitch point.
6. Stop the tractor engine, place all controls in neutral, set park brake and remove ignition key before dismounting.
7. Install a drawbar pin with provisions for a mechanical retainer such as a Klick pin. Install the retainer.
8. Attach the safety chain between the machine and the tractor drawbar cage.

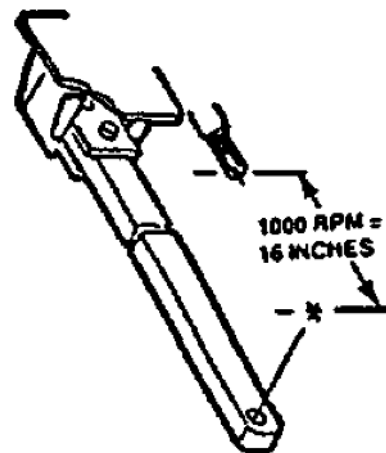

4 OPERATION

9. Connect the PTO shaft:

- a. Check that the PTO driveline telescopes easily and that the shield rotates freely.
- b. Attach the driveline to the tractor by retracting the locking sleeve, slide the yoke over the shaft and push on the yoke until the lock sleeve clicks into position. Pull on the yoke to be sure the driveline is locked on the shaft.

10. Connect the hydraulics:

- a. Use a clean cloth or paper towel to clean the couplers on the ends of the hoses. Also clean the area around the couplers on the tractor.
- b. Remove the plastic plugs from the couplers and isolate the hoses for the lift arm circuit from the hoses for the cradle tilt circuit.
- c. Match the appropriate hoses with the desired control lever in the tractor for ease of operation. Insert the male ends of the hoses into the female couplers on the tractor.

11. Route the hoses along the hitch and secure in position to prevent entanglement with any moving parts.

12. Lower the hitch jack and rotate it 90° to place in its stowed position.

13. When unhooking from the tractor, reverse the above procedure. Use a plank under jack if ground conditions are soft.



4 OPERATION

4.7 Field Operation

4.7.1 Loading and Processing

- 1) Lower bale tines to ground.
- 2) Back processor up with the bale tines sliding under the bale.

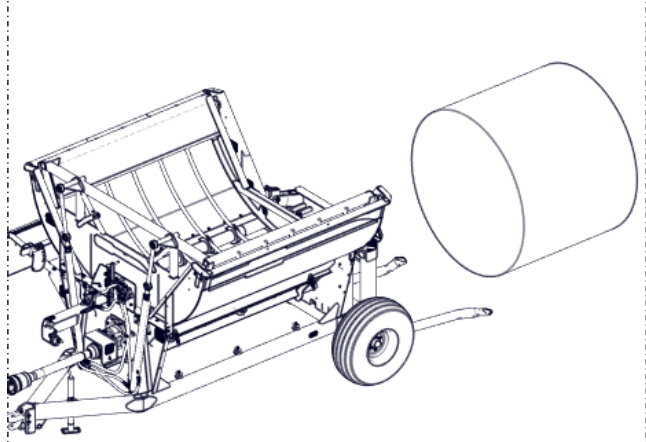

- 3) Slowly raise the tines until the bale clears the ground.
- 4) Remove strings, twine, or wrapping from the bale.

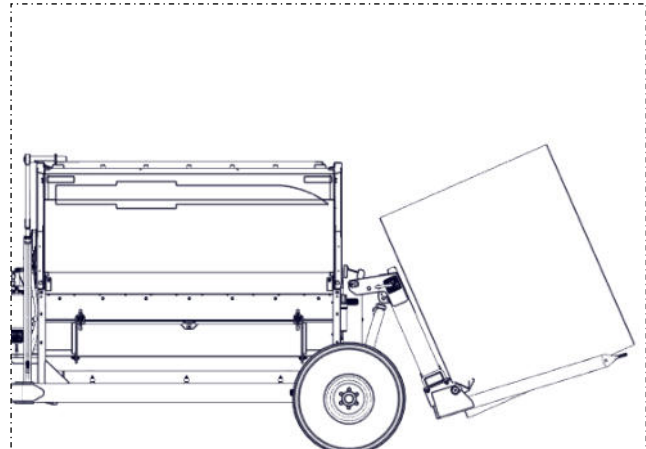

- 5) Raise the bale tines up and tip the bale into the bale cradle.

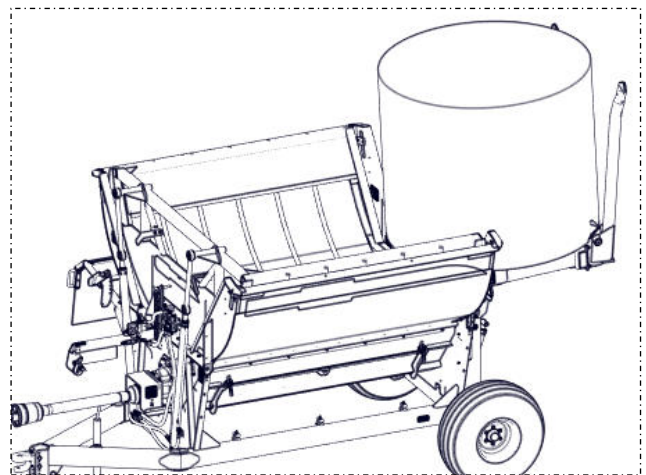

***** STOP CRADLE WHEN LOADING BALES INTO PROCESSOR *****

4 OPERATION

6) At this time a second bale can be picked up on the forks and brought along to the feeding area if desired.

Important: When the second bale is loaded on the bale tines, make sure that the loaded bale does not interfere with the cradle operation. Interference can cause damage to the cradle.

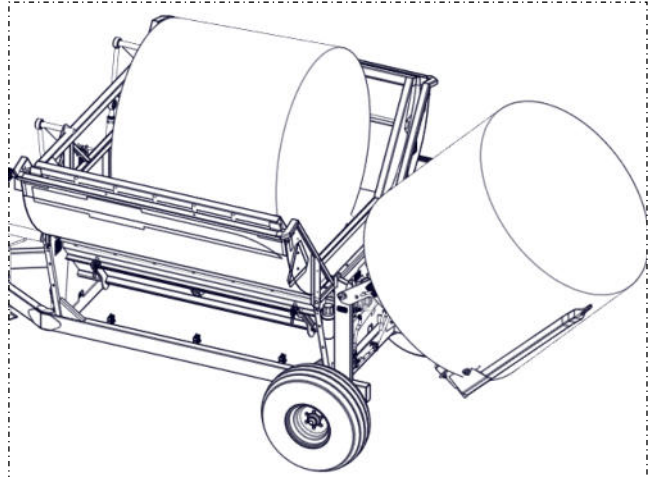

- 7) Processing:
- Set the discharge deflector to the desired position.
 - Start the tractor and run on idle.
 - Drive to the desired unloading location.
 - With the tractor on idle, slowly engage PTO.
 - Increase engine RPM to rated PTO speed.
 - Engage rocking bale cradle hydraulic circuit.

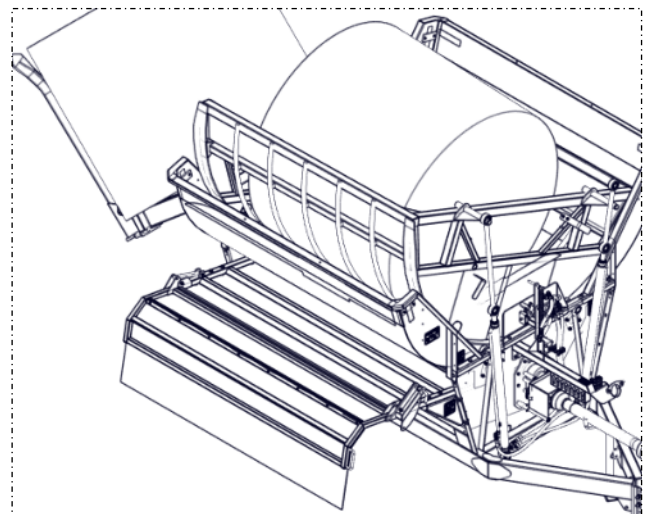

IMPORTANT

The processor is equipped with an 80° constant velocity drive line. When operating the Bale Processor, keep the PTO drive line as straight as possible to have the universal joint angles as small as possible during operation. Avoid sharp turns with the PTO engaged. If a sharp turn is unavoidable, disengage the PTO for the turn and then re-engage when appropriate to do so. Operating at more than 80° will damage the CV joint and will void warranty.

OPERATION TIP

Before engaging PTO it is a good practice to clock the bale slightly to the left or right. This allows the hammers to swirl freely on start-up and get up to operational speed prior to processing the bale. This can increase hammer longevity as there is less backslap from the hammers as they can swing back and hit the rotor pipe when the material resistance is higher than the hammer momentum.

***** STOP CRADLE WHEN LOADING BALES INTO PROCESSOR *****

4 OPERATION

4.7.2 Stopping:

- a. Disengage cradle tilt hydraulic circuit.
- b. Allow rotor to run until no more material comes out of discharge opening.
- c. Slowly decrease engine RPM to idle.
- d. Disengage PTO drive and wait for rotor to stop turning.

IMPORTANT

Disengage PTO clutch and wait until rotor stops turning before pushing the PTO clutch lever into its off position. If the PTO drive system on your tractor is designed with a brake that will stop the PTO shaft in less than one revolution, avoid using this feature. Stopping the rotor too quickly will break the PTO shear pin.

Each input drive line is designed with a shear bolt to protect the machine from shock impact loads. If the shear bolt breaks, remove the broken pieces and replace with genuine JIFFY replacement parts. Remove all material from the processor before restarting the machine.

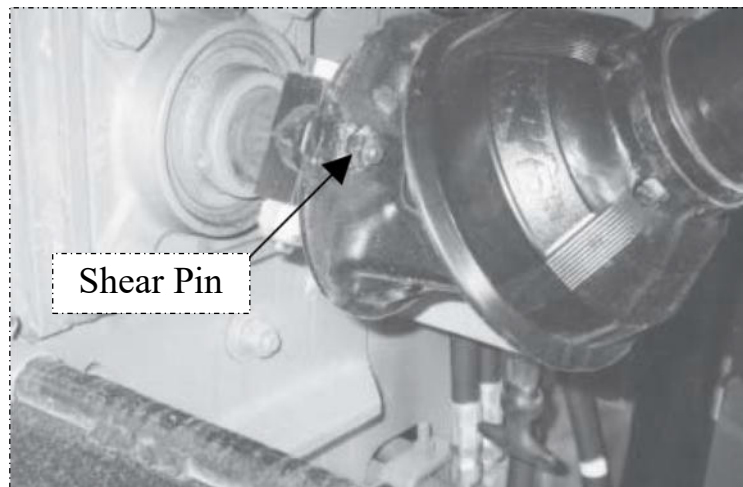

4 OPERATION

4.7.3 Rotor Cleaning:

The string or twine from the bales does get tangled around the rotor as the bales are processed. Check every few bales to make sure there is nothing entangled in the rotor and remove and clean as required. Twine can prevent the flails from swinging and affect function or rotor balance. Access the rotor through the side access door on the side opposite to the discharge opening. Always stop the engine and remove the ignition key before cleaning the rotor.

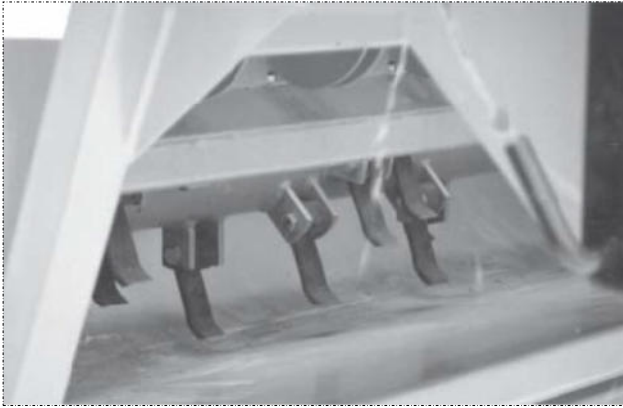

4.7.4 Cradle Tilt:

The machine is designed with a cradle inside the frame that moves the material from side-to-side across the rotating flails. It is designed to tilt the bale to one side until it is just ready to roll and then it tilts to the other side.

The best results are obtained when a full cycle takes 10 to 12 seconds to complete. Use the flow dividers on the tractor and on the front of the Bale Processor to set the speed of the cradle. Refer to the Maintenance section for the detailed setting procedure.

4 OPERATION

4.7.5 Flail Backslap:

The rotor is designed with swinging flails that process the material as the cradle moves the bale across the rotor. Each flail is held in the extended position by the centrifugal force from the rotor rotation. Each flail must be free to swing as the material moves across the rotor. If you hear the flails backslapping against the rotor:

- a. Repair or replace any damaged or broken parts.
- b. Slow the cradle tilt speed. Backslap can occur if the material is being moved into the rotor too fast. Slowing the tilt speed moves less material into the flail and they will not have to swing back out of the way.
- c. Clean the rotor. Entangled material can affect how the flails swing and contribute to backslap.

Tough and/or frozen bales are significant contributors to increased backslap, and may require slower cradle speeds to safely process the bale. When beginning these tough bales, it may be necessary to move the cradle off center to ensure less/minimal bale contact on startup to reduce the chances of backslap early on in the processing function.

Note: Choosing to ignore the effects of continuous or repeated backslapping will result in damage to the rotor surface, which over time may result in cracks and eventual failure .

4.7.6 Bale Tines:

It is recommended that the bale tines be raised into the vertical position when operating in and around livestock to prevent inadvertent injury to the animals.

4.7.7 Operating Tips:

- a. Keep the PTO driveline as straight as possible to minimize universal joint angles.
- b. Disengage PTO when making sharp turns. Never exceed a universal joint angle of 80°.
- c. Always try to remove the twine, string or wrapping from the bale before tipping into the machine to reduce rotor wrapping.
- d. Do not store bales or other material in the machine overnight in cold weather. Material can freeze to the frame cradle and jam the rotor.
- e. Always stop the engine, remove the ignition key, disconnect hydraulic lines and remove the PTO shaft before working on the machine.
- f. Do not point the discharge at people, animals or buildings. Material can be thrown out fast enough to injure someone.
- g. Slowly raise the arms to tilt the bale into the machine. The machine will hold an entire round bale. Large square bales may have to be broken in pieces. Be sure to remove strings, twine or wrapping before loading.
- h. Engage the cradle tilt circuit after the rotor has been brought to full or rated speed. This will move the material across the rotor for even feeding and processing.

4 OPERATION

4.8 Transporting

1. Be sure that the unit is hitched properly to the towing vehicle. Always use a retainer in the drawbar pin and a safety chain between the machine and the tow vehicle.
2. Install lift frame lock pin before transporting.
3. If transporting with a tractor, install a SMV (Slow Moving Vehicle) emblem in the location provided.
4. Always use hazard warning flashers on the tractor when transporting unless prohibited by law.
5. Do not exceed 20 mph (32 kph). Reduce speed on rough roads and surfaces.
6. Keep to the right and yield the right-of-way to allow faster traffic to pass.
7. Make sure the SMV (Slow Moving Vehicle) emblem and all the lights and reflectors that are required by the local highway and transportation authorities are in place, are clean and can be seen clearly by all overtaking and oncoming traffic.
8. Make sure you are in compliance with all local regulations regarding transporting equipment on public roads and highways.

NOTE: Use two safety chains when using a truck to transport the processor and cross them under the hitch when connecting (As shown in picture below).



4 OPERATION

4.9 Storage

At the end of the season, the machine should be thoroughly inspected and prepared for storage. Repair or replace any worn or damaged components to prevent any unnecessary down time at the start of the next season.

Follow this procedure:

1. Wash the entire machine thoroughly using a water hose or pressure washer to remove all dirt, mud, debris or residue.
2. Inspect all drives and moving parts. Remove any string, twine or other material that has become entangled in the rotor, flails, cradle components or shafts. Be sure all components are clean and can move freely.
3. Inspect all hydraulic hoses, fittings, lines, couplers and valves. Tighten any loose fittings. Replace any hose that is badly cut, nicked or abraded or is separating from the crimped end of the fitting.
4. Inspect rotor and flails for damaged or broken components. Repair or replace components as required.
5. Lubricate all grease points. Make sure all grease cavities have been filled with grease to remove any water residue from the washing.
6. Raise lift arms to their fully up position and install lock pin.
7. Apply "never seize" or grease to PTO input shaft and cylinder rams.
8. Touch up all paint nicks and scratches to prevent rusting.
9. Move the machine to its storage location.
10. Select an area that is dry, level and free of debris.
11. Place planks under the jack for added support if required.
12. Unhook the machine from the tractor (Refer to Section 4.6).
13. Cover the machine with a tarp if the machine is not stored inside.

5 SERVICE AND MAINTENANCE

5.1 Servicing Record

1. Grease: Use an SAE multi-purpose high temperature grease with extreme pressure (EP) characteristics. Also acceptable is an SAE multipurpose lithium based grease.

2. Lubricants: Your unit can operate at top efficiency only if clean lubricants are used. Use clean containers to handle all lubricants. Store them in an area protected from dust, moisture and other contaminants. Gearbox on Model 2958 takes 300ml of SAE 80W-90 Gear Oil.

ACTION CODE: CL.....CLEAN
L.....LUBRICATE

T.....TIGHTEN
CH.....CHECK

<div style="display: flex; justify-content: space-between;"> MAINTENANCE Hours Serviced By </div>										
	8 Hours, Daily or 10 Bales									
L PTO Shaft (8)										
I Rotor and Flails										
I Wheel Bearings										
I Shear Bolts										
I Gearbox Seals										
Weekly or 50 Bales										
G Bale Cradle Bushings (4)										
G Bale Lift Bushing Bushings (8)										
G Rotor/Roller Bearings (6)										
I Gearbox Oil Level										
Annually or 3000 Bales										
G Wheel Bearings										
L Gearbox—Change Oil										
W Machine										

5 SERVICE AND MAINTENANCE

5.2 Servicing Intervals

Grease

Use an S.A.E. multi-purpose high temperature grease with extreme pressure (EP) performance. An S.A.E. multi-purpose lithium base grease is also acceptable.

Use the Maintenance Checklist provided to keep a record of all scheduled maintenance.

1. Only use a hand-held grease gun for all greasing.
2. Wipe grease fittings with a clean cloth before greasing to avoid injecting dirt and grit.
3. Replace and repair broken fittings immediately.
4. If a fitting will not take grease, remove and clean thoroughly. Clean the lubricant passage-way also. Replace fittings as necessary.

Oil

Use 80W90 oil for discharge auger gearbox.

Use the Maintenance Checklist provided to keep a record of all scheduled maintenance.

PTO, front and rear yoke: grease zerk (every 8 hours)

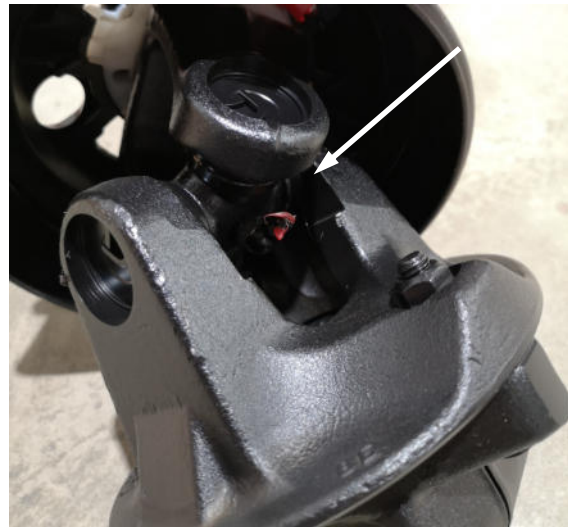

PTO, mid: grease zerk, extend PTO and rotate shield to find zerk (every 8 hours)



PTO: grease zerk (every 8 hours)

5 SERVICE AND MAINTENANCE

5.2 Servicing Intervals

1. Use a hand-held grease gun for all greasing.
2. Wipe grease fitting with a clean cloth before greasing to avoid injecting dirt and grit.
3. Replace and repair broken fittings immediately.
4. If fittings will not take grease, remove and clean thoroughly. Also clean lubricant passage-way. Replace fitting if necessary.

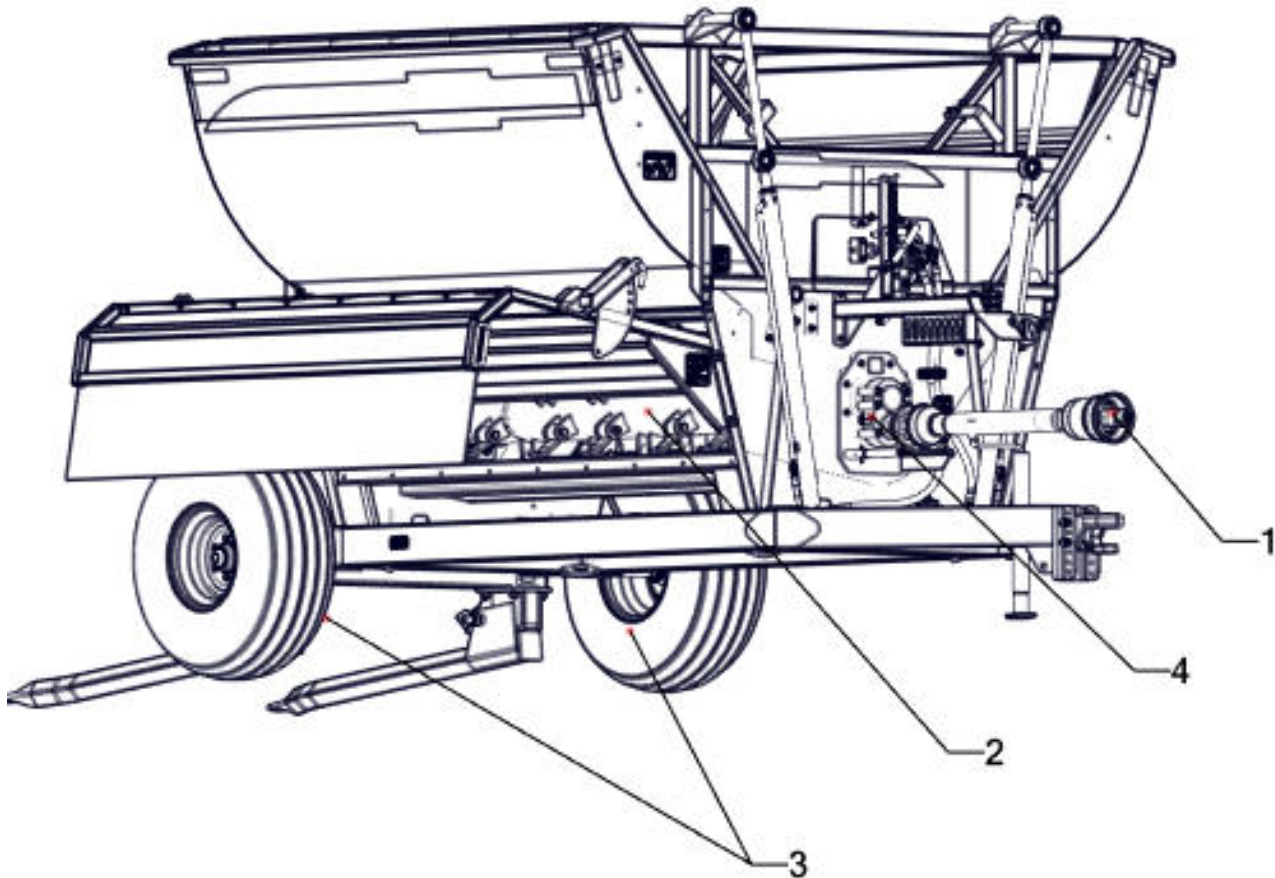

5.2.1 8 Hours, Daily or Every 10 Bales:

1. Lubricate the PTO shaft (eight locations). See Lubrication Procedure from Weasler (page 5.5). Follow **Standard Interval Schedule**.
2. Check the conditions of the rotor and flails. Remove all entangled material. Repair damaged components. Replace broken components.
3. Check wheel bearings. Remove twine or other entangled material.
4. Check shear bolt. Tighten if loose. Replace if broken or damaged.

5 SERVICE AND MAINTENANCE

5.2 Servicing Intervals

5.2.2 Weekly or Every 50 Bales:

1. Grease the bale cradle bushings (four locations).
2. Grease the bale lift system bushings (eight locations).
3. Grease roller and rotor bearing (six locations).
 - a. Rollers
 - b. Rotor
4. Check gearbox for signs of wear or leakage.

5.2.3 Annually Or Every 3000 Bales:

5. Repack wheel bearings.
6. Change oil in gear box (300ml SAE 80W-90 Gear Oil).
7. Wash and clean machine.

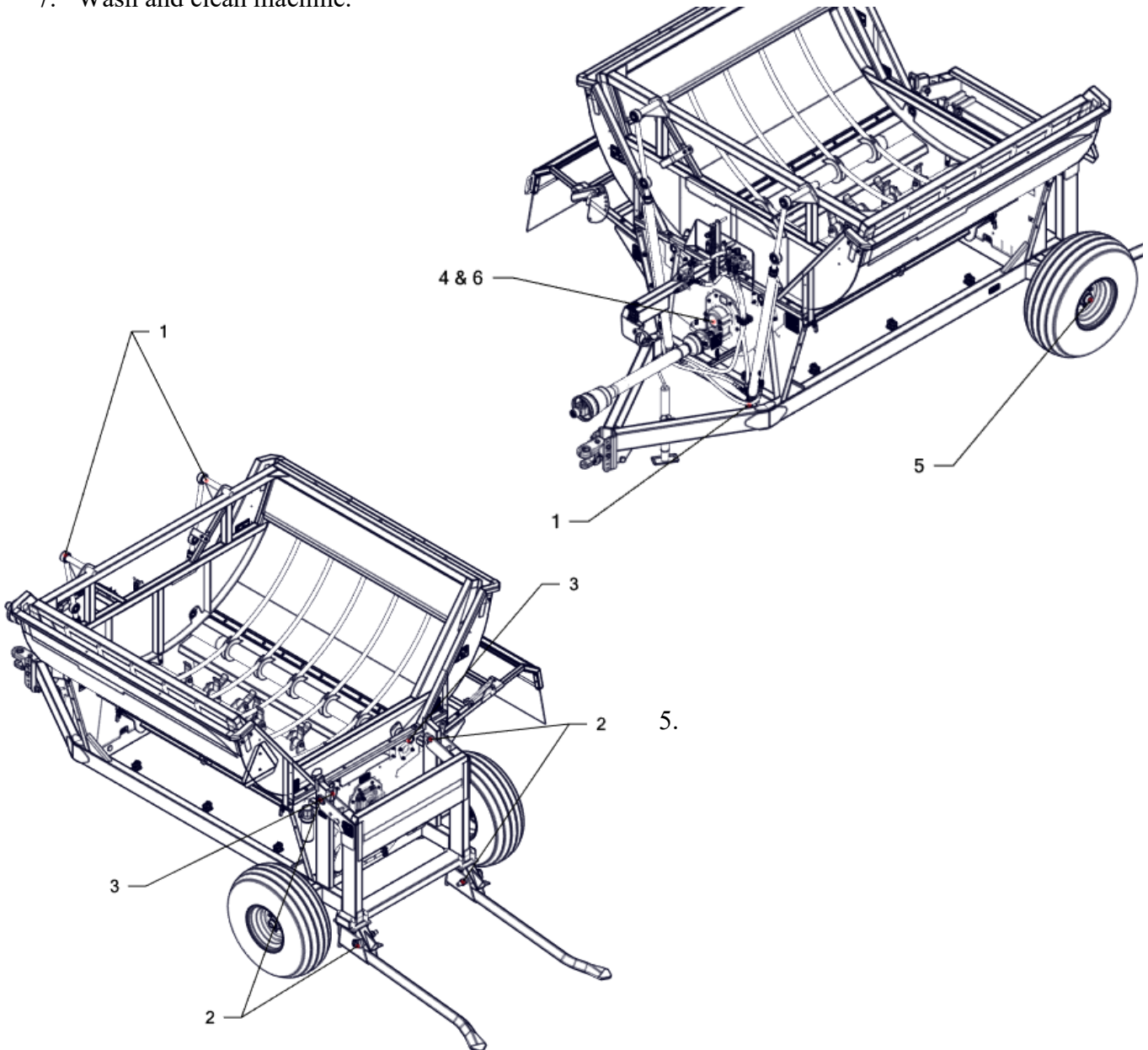

5 SERVICE AND MAINTENANCE

5.3 Gearbox

Gearbox Oil Level

The Level Plug for the 2958 gearbox is located on the front of the gearbox, just above the PTO input shaft. When the plug is removed the oil should sit flush with the bottom of the opening.

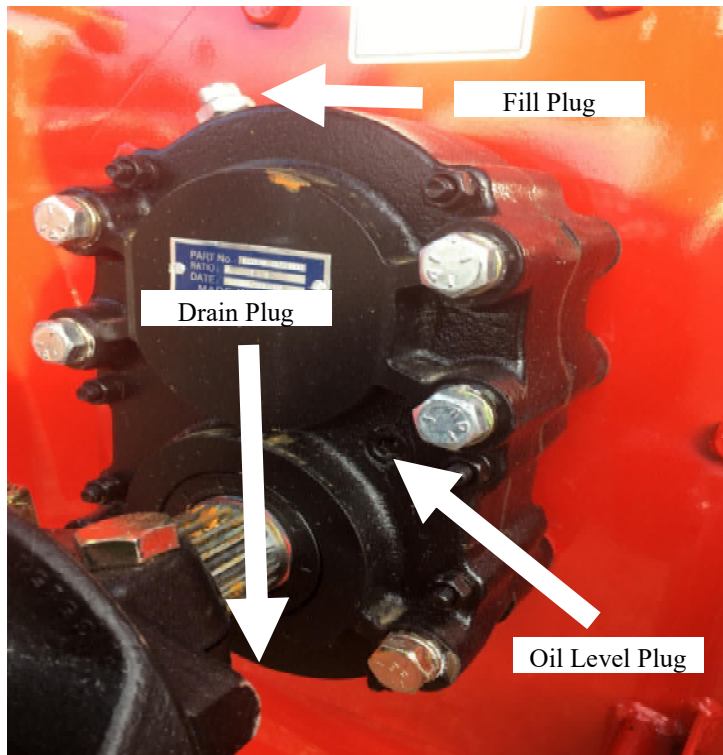

5 SERVICE AND MAINTENANCE

5.4 Maintenance & Adjustments

5.4.1 Rocking Bale Cradle System

The Processor is designed with a system that automatically reverses the cradle direction during operation to evenly move the bale over the rotor for efficient processing. When maintaining the cradle system, follow this procedure:

5.4.2. Stroke:

The cradle is designed to tilt from side to side during operation to prevent bridging over the rotor and flails. Its objective is to tilt to one side until the bale is almost ready to roll and then tilt to the other side.

- Move the stroke stops on the bale cradle to set the stroke.
- Move the stop up to increase the stroke and down to decrease stroke.
- The stroke stops have their own stop tabs to prevent them from being set too high. The factory setting will provide the best performance and is set at 1-1/2" from the stop tabs.

NOTE: *In general, soft, wet bales require more stroke than hard, well formed bales. The type of material being processed will also affect the adjustment of the total stroke.*

5.4.3 Speed:

Use the tractor hydraulic system and cradle flow divider to set the tilting speed.

- Set the cradle frame actuator arms to provide maximum stroke.
- Set the tractor hydraulic system flow control to its 1/4 flow position.
- Set the processor flow at maximum (7 on scale).
- Start engine and engage cradle tilt circuit.
- Time a full cycle. It should not be less than 8 seconds.
- Use the tractor flow divider to set the cycle speed.
- Use the Processor flow control to set the speed if the tractor is not equipped with a flow control.

NOTE: *The best results are obtained when it takes 10 to 12 seconds to go through one complete cycle.*

Adjust to maximum stroke (no gap) when setting the tractor hydraulic system.

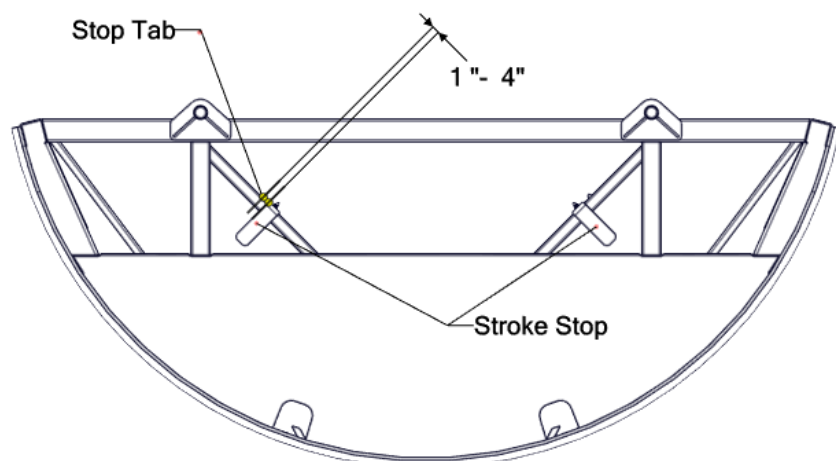

5 SERVICE AND MAINTENANCE

5.4 Maintenance & Adjustment Cont'd

5.4.4 Cradle Shifting Valve:

The cradle shifting valve mechanism has been adjusted at the factory and should not require adjustment during normal use of the machine. If, however, the valve or other components need to be serviced, the following guidelines should be used to position the valve properly on its mounting plate:

- Assemble the shift spool to the valve body.
- Position valve on the mounting plate and install mounting bolts. Finger tighten bolts to allow moving if required.
- Slide the valve spool to its neutral position (5/16" extended).
- Slide the valve assembly until it is centered between stops. Tighten mounting bolts to their specified torque.
- Adjust the stop bolt so that when the valve shift lever is touching the stop bolt there is approximately 1/32 inch clearance between the shift spool flange and the stop welded to the valve plate.
- Move the shift lever to the other side and adjust the other stop bolt in the same manner.
- Check that the shifting action is smooth and that no binding occurs.
- Install spring and reconnect hoses.

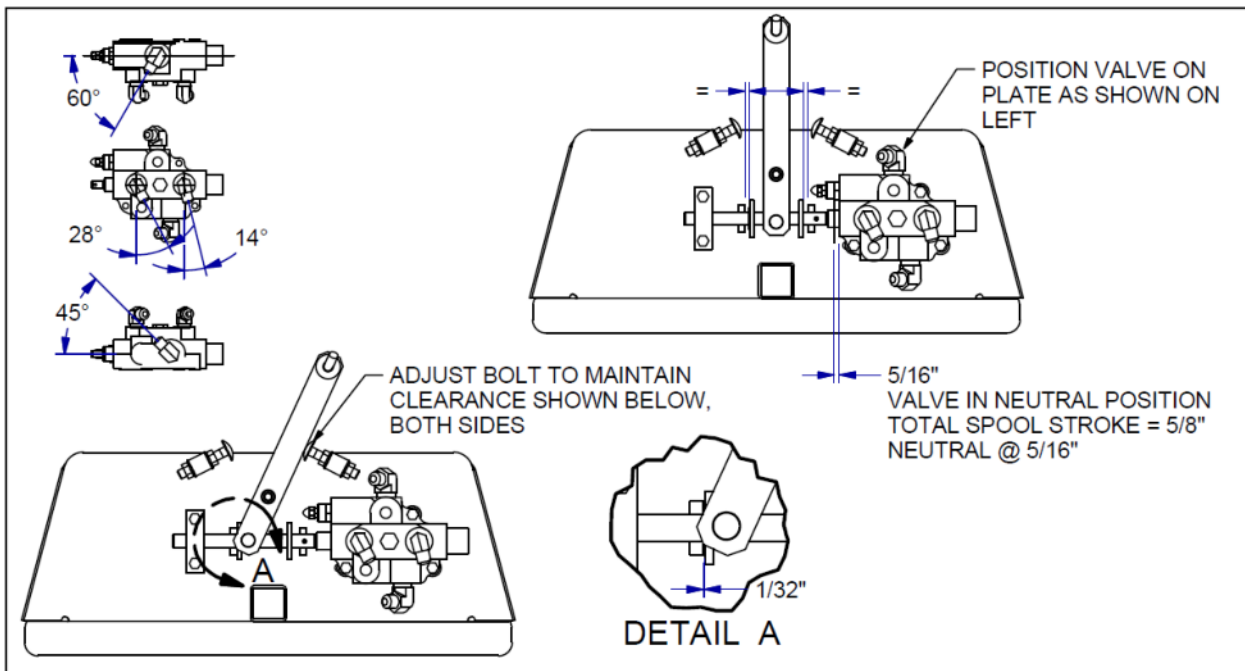

5.4.5 Flail Backslap:

Regardless of the type of bale, persistent hammer backslap is detrimental to processor operation. Hammer backslap at start-up is normal and disappears once the rotor is up to speed. If your processor experiences frequent hammer backslap, the cause should be investigated and rectified. In most cases reducing the cradle speed will correct the problem.

5 SERVICE AND MAINTENANCE

5.4 Maintenance & Adjustment Cont'd

5.4.6 Rotor Maintenance:

1. Place all controls in neutral, stop the engine, set the parking brake, remove the ignition key, disconnect the PTO shaft and remove the hydraulic hoses.
2. Use a knife, shears, or some other cutting device to remove string, twine or other entangled material. Be sure to remove everything by the flail mounting bolts to allow them to swing freely. You can access the rotor from the side access door, on the side opposite to the discharge opening.
3. Keep flails in good condition. Replace if chipped, bent or damaged in any way. Always use a locking nut or jam nut on the flail bolt to prevent it from coming apart.

5.4.7 PTO Safety Shield:

It is important that the shield components rotate freely over the PTO shaft. Lubricating both the shield bearings and cleaning periodically will ensure the safe operation of the rotating shields.

1. Press the cone down and release the collar catches with a screw driver.
2. Spread the collar bearing and remove from the tube.
3. Clean the collar and the yoke bearing groove. After cleaning thoroughly, apply a good coating of grease to the bearing groove.
4. Fit the collar bearing into the groove and the tube ensuring that the collar catches are centered over the matching holes. The tube and bearing must rotate freely in the bearing groove.
5. Fasten the cone by lining up the cone grease fitting over the grease filling hole on the collar bearing. Make sure that all catches are fastened and that the shield turns freely over the shaft.

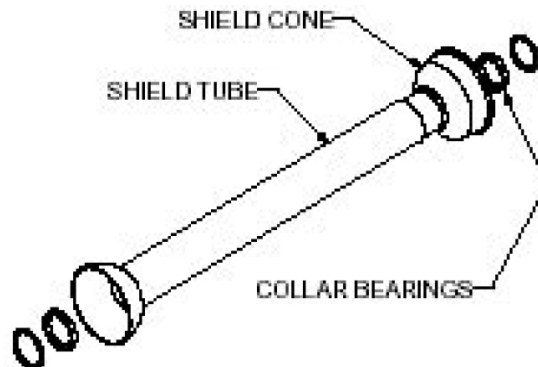

Safety Shield Components

5.4.8 Shear Bolts:

Each PTO driveline is equipped with a shear bolt on the implement end of the driveline. It is used to protect the Processor from jamming, plugging or overloading. Replace the shear bolt as needed. Be sure to use the appropriate shear bolt when replacing. Using the wrong shear bolt can result in damage to the machine.

Refer to Machine Specifications for proper shear bolt sizing (Section 7).

5 SERVICE AND MAINTENANCE

5.4 Maintenance & Adjustment Cont'd

5.4.9 Hitch:

The H&S Bale Processor is equipped with an adjustable clevis style hitch. It is a two piece design and is to be installed as shown. Do not use the hitch with the clevis on top as it does not have sufficient strength to support the vertical loads imposed by the Processor. Do not remove the clevis section unless the tractor drawbar is equipped with a clevis. The clevis is required to counter the uplifting forces that can be encountered under some circumstances. Adjust the height of the hitch so that the Processor is level when connected to the tractor.

On tractors equipped with a clevis style drawbar, the clevis on the Processor must be removed to prevent binding when turning or on uneven terrain.

Check hitch and clevis bolts on a weekly basis to make sure they are properly tightened.

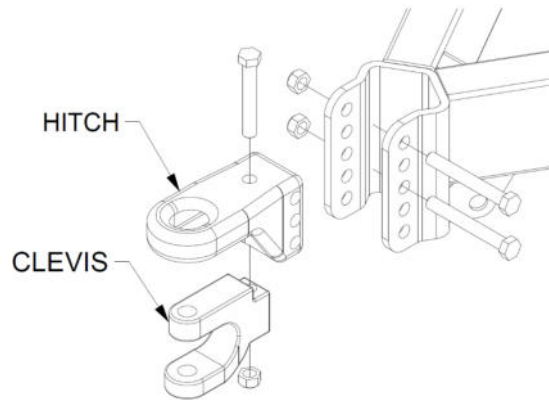

5.4.10 Bale Loading Forks:

The bale loading forks have three hole positions for the two U-bolts. This will allow for the forks to be moved inward. For standard sized round bales with a diameter of 5' to 6' the forks should be left in the factory position which places the fork directly in-line with the vertical HSS on the load frame. For silage bales, the forks should be moved in to better carry and load the typical 4' diameter bales. The diagram below indicates both the factory set position and the fork set more in-board for smaller diameter bales.

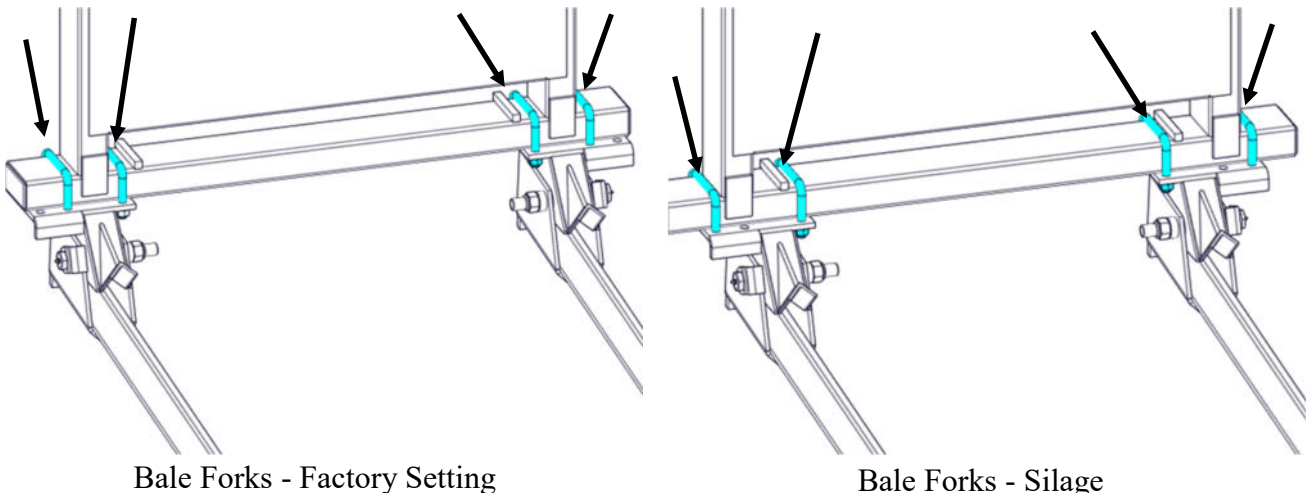

**THIS PAGE INTENTIONALLY LEFT
BLANK**

6 PDI SETUP

Your JIFFY Bale Processor is shipped fully assembled. Take all necessary precautions when moving and operating the equipment.

After the PTO is installed, there is no provision for transportation. The owner must secure it (or remove the front half) during transportation.

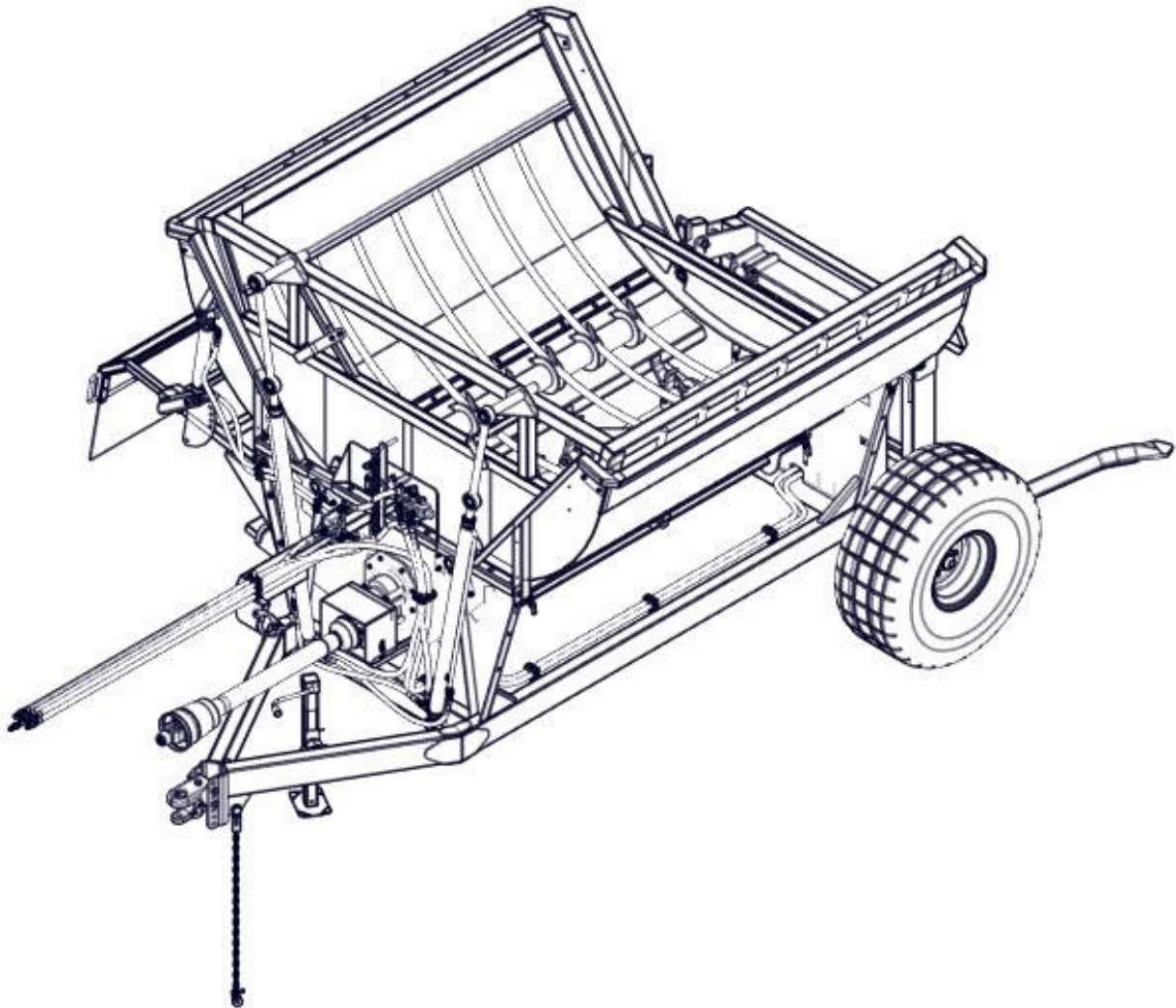

IMPORTANT: Use proper safety procedures while lifting heavy objects.

7 TRANSPORTATION



1. Check with local authorities regarding Bale Processor transportation on public roads. Obey all applicable laws and regulations.
2. Always travel at a safe speed. Use caution when going around corners or meeting traffic.
3. Make sure an SMV (Slow Moving Vehicle) emblem and all the lights and reflectors that are required by local highway and transportation authorities are in place, are clean and can be seen clearly by all overtaking and oncoming traffic.
4. If possible use a light kit when transporting. Be sure all lights attached to the rear of the Bale Processor are working to safeguard against rear end collisions. Daybreak and dusk are particularly dangerous and pilot vehicles are recommended.
5. Be sure that the Bale Processor is hitched positively to the towing vehicle and a retainer is used through the drawbar pin. Always use a safety chain between the machine and the towing unit.
6. Keep to the side and yield the right-of-way to allow faster traffic to pass. Drive on the shoulder of the road if safe to do so and permitted by law.
7. Do not exceed a 25mph (40kph) travelling speed. Reduce speed on rough roads and surfaces. Reduce speed when going around tight bends and corners in the road. Be especially careful when traveling on roads with a significant center crown, or when moving to the shoulder of the road with one wheel.
8. Always use the hazard warning flashers on the tractor when transporting unless prohibited by law.
9. When transporting a Bale Processor with a conveyor discharge, be aware of overhead power lines at all times.

Do not transport the Bale Processor without all of the transport pins and clamps installed and fastened.

8 STORAGE

8.1 Placing in Storage

At the end of the operating season, the machine should be thoroughly inspected and prepared for storage. Repair or replace any worn or damaged components to prevent any unnecessary down time at the beginning of the next season. Follow this procedure:

1. Empty the chamber of any twine or residual material.
2. Thoroughly clean the machine to remove all dirt, mud, debris or residue.
3. Lubricate all grease points. Make sure all grease cavities have been filled with grease to remove any water left over from clean up.
4. Inspect all hydraulic hoses, couplers and fittings. Tighten any loose fittings. Replace any hose that is badly cut, nicked, abraded or is separating from the crimped end of a fitting.
5. Touch up all paint nicks and scratches to prevent rusting.
6. Move the machine to the storage location.
7. Select an area that is dry, level and free of debris.
8. Chock the tires, front and rear, to prevent the machine from rolling.
9. Place planks under the jack for added support if required.
10. Unhook the machine from the tractor.

8.2 Removing from Storage & Pre-Season Preparation

When removing from storage and preparing to use, follow this procedure:

1. Clear the area of bystanders, especially small children, and remove foreign objects from the machine and the working area.
2. Remove any storage covers used to protect the machine.
3. Attach the Bale Processor to the tractor.
4. **INSPECTION:**
 - a) Check that all hydraulic lines are seated and completely coupled.
 - b) Check that all of the bearing locking collars on the shafts are tight and in good condition.
 - c) Check that all set screws on the bearing collars are tight.
 - d) Check that all bearing mounting bolts are tight.
 - e) Check that all tires are inflated per the recommended pressures.
 - f) Re-torque all wheel bolts.
5. Lubricate all grease fittings.
6. Replace any defective parts.
7. Go through the **Pre-Operational Checklist** (Section 4.3) before using.

9 TROUBLESHOOTING GUIDE

The Bale Shredder is designed to pick up bales and load them in the cradle where they are moved into a high speed rotor for shredding. It is a simple and reliable system that requires minimum maintenance.

In the following section we have listed potential problems, causes and solutions to the problems you may encounter.

If you encounter a problem that is difficult to solve, even after having read through this troubleshooting section, please call your dealer or distributor. Before you call, please have this Operator's Manual and the serial number from your machine ready.

PROBLEM	CAUSE	SOLUTION
Machine Vibrates	Rotor out of balance	Check rotor, remove entangled material Be sure all Flails swing freely
		Check Rotor, replace and bent, broken, or missing Flails
Lift frame lifts slowly	Insufficient oil flow	Increase oil flow at tractor or flow divider.
	Cold temperatures	Warm machine before operating.
		Check hydraulic oil type in tractor.
Shear bolt failure	Rotor does not turn freely	Determine and correct the cause of hard turning. The rotor must turn freely.
		Remove entangled material from rotor, flails shafts, and bearings.
		Replace shear bolts.
	PTO engaged too quickly	Engage the PTO slowly (see tractors opera- tors manual)
	PTO Disengaged at high RPM	Reduce tractor speed to idle before disengag- ing PTO.
Check to see if the PTO brake (if equipped) is not engaged, prior to stopping the rotor.		
Poor shredding performance	Improper cradle align- ment	Check cradle rollers, gaps larger than 3/16" will cause cradle lift. Adjust roller gap to 3/16"
Low throwing distance	Improper cradle align- ment	Check cradle rollers, gaps larger than 3/16" will cause cradle lift. Adjust roller gap to 3/16"
	Low Rpm	Ensure PTO runs at 1000RPM
Uneven cradle move- ment speeds	Improper valve position- ing	Adjust the position of cradle rocking valve and shifter spool

10 SPECIFICATIONS

10.1 General Specifications

Weight.....5750 lbs
Minimum Tractor Horsepower.....100 hp - PTO
Tub Length.....83”
Discharge DirectionRight

Capacity will change with moisture content, roll configuration and particle size desired.

10.2 Tire Specifications





Tire/Rim..... Tire & Rim 16.5L x 16.1SL x 14rim
Tire Pressure Check Tire for Info

10.3 Bolt Torque Specifications

PTO shear bolts..... 2” x 3/8” NC Gr 8
..... *All Other Bolts—Refer to Bolt Torque Chart On Following Page*

10 SPECIFICATIONS

BOLT TORQUE CHART

SIZE	 SAE GRADE 2		 SAE GRADE 5		 SAE GRADE 8		 L9
	ASSEMBLY TORQUE DRY	LUBRICATED	ASSEMBLY TORQUE DRY	LUBRICATED	ASSEMBLY TORQUE DRY	LUBRICATED	ASSEMBLY TORQUE LUBRICATED
1/4-20	66*	49*	8	75*	12	9	11
1/4-28	76*	56*	10	86*	14	10	13
5/16-18	11	8	17	13	20	18	21
5/16-24	12	9	19	14	25	20	23
3/8-16	20	15	30	23	45	30	33
3/8-24	23	17	35	25	50	35	38
7/16-14	30	24	50	35	70	55	60
7/16-20	35	25	55	40	80	60	65
1/2-13	50	35	75	55	110	80	95
1/2-20	55	40	90	65	120	90	105
9/16-12	65	50	110	80	150	110	140
9/16-18	75	55	120	90	170	130	150
5/8-11	90	70	150	110	220	170	185
5/8-18	100	80	180	130	240	180	205
3/4-10	160	120	260	200	380	280	290
3/4-16	180	140	300	220	420	320	355
7/8-9	190	140	400	300	600	460	505
7/8-14	210	155	440	320	660	500	585
1-8	220	160	580	440	900	680	775
1-14	240	170	640	480	1000	740	900
1 1/8-7	300	220	800	600	1280	960	1150
1 1/8-12	340	260	880	660	1440	1080	1325
1 1/4-7	420	320	1120	840	1820	1360	1600
1 1/4-12	460	360	1240	920	2000	1500	1750
1 3/8-6	560	420	1460	1100	2380	1780	—
1 3/8-12	640	460	1680	1260	2720	2040	—
1 1/2-6	740	560	1940	1460	3160	2360	3250
1 1/2-12	840	620	2200	1640	3560	2660	3650

**ITEMS WITH * = INCH POUNDS
ALL OTHERS = FOOT POUNDS**

**"LUBRICATED"
INCLUDES LUBRICANTS, LUBRIZING, PLATING, AND HARDENED WASHERS**

10 SPECIFICATIONS

10.4 Overall Dimensions

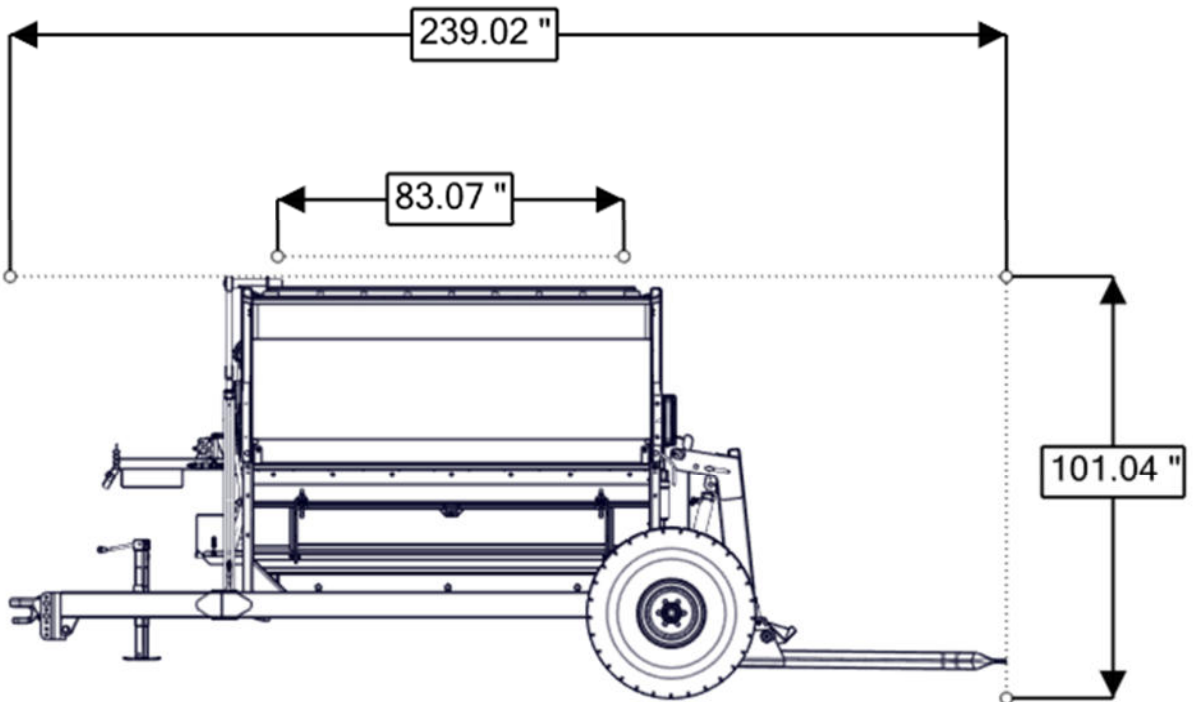
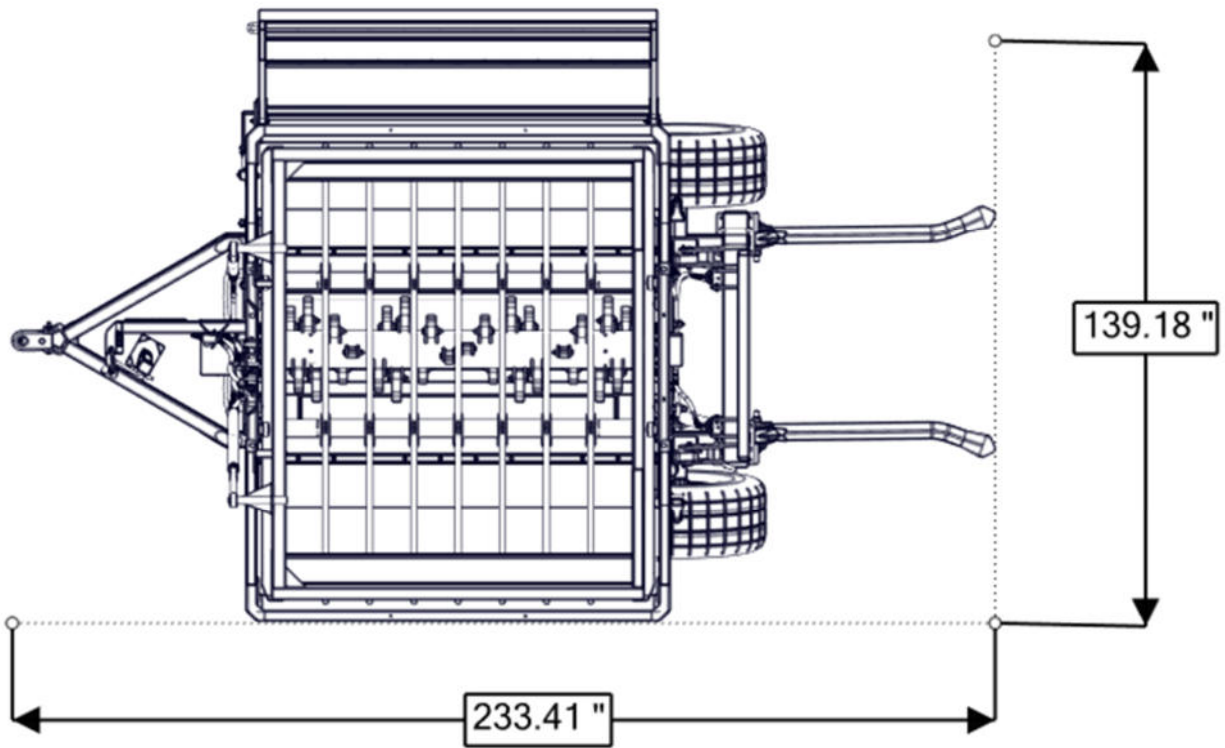

10 SPECIFICATIONS

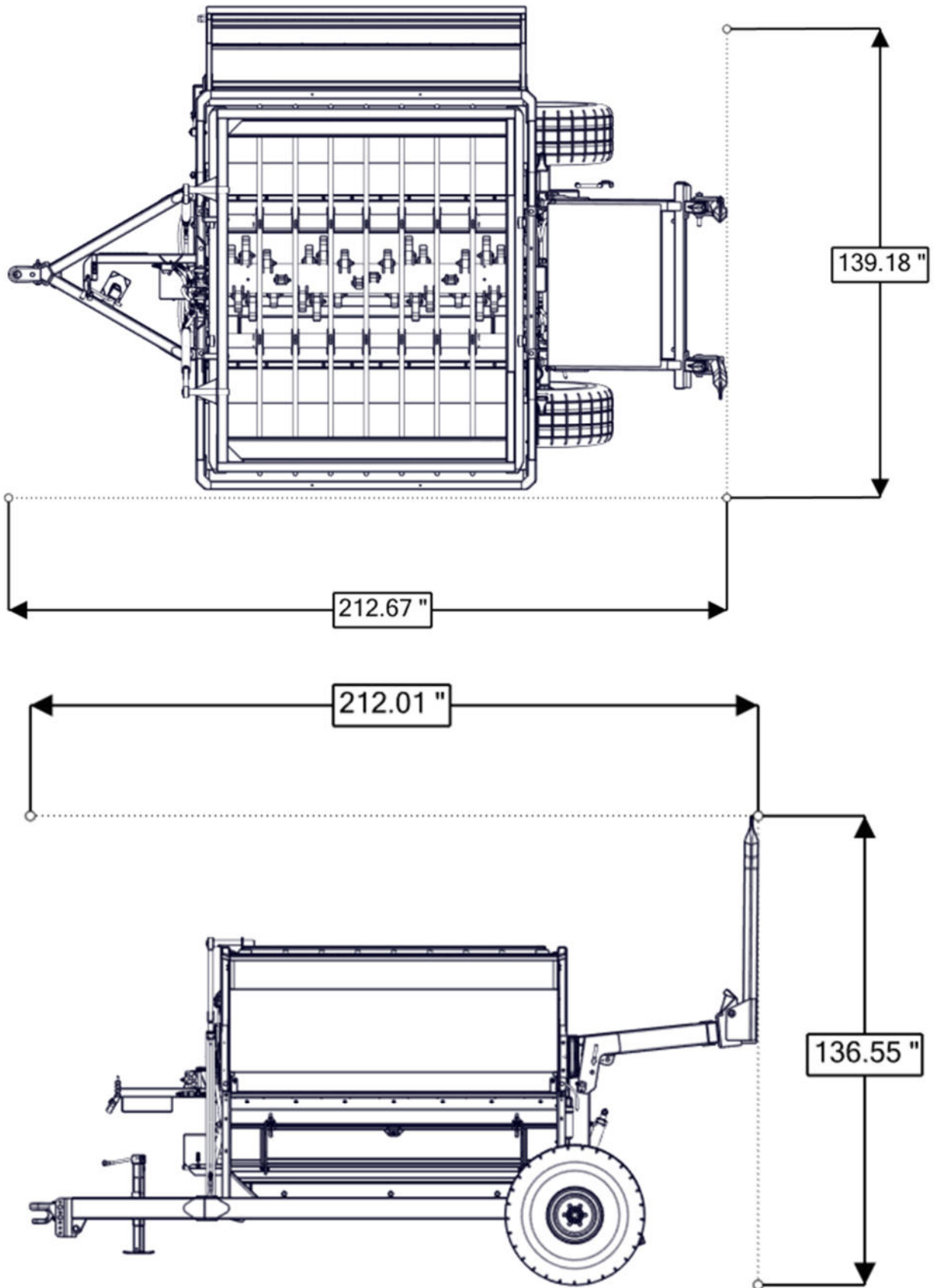

11 PARTS

11.1 Frame Assembly

REF #	PART #	DESCRIPTION	QTY
1	160300-0020	Socket Head Cap Screw - 3/8" x 1-1/4" NC	8
2	147100-0291	Cradle Guide	4
3	167200-0652	Nyloc Nut - 3/8" NC Gr.5 PL	27
4	J62800-0021.00	Shroud Weldment	2
**	163000-0507	Carriage Bolt - 3/8" NC x 1" Gr.5 PL	24
**	167200-0510	Hex Nut - Flanged - 3/8" NC Gr.5 PL	24
5	159400-0401	Hex Bolt - 1/2" NC x 1-1/2" Gr.5 PL	2
6	167200-0642	Nyloc Nut - 1/4" NC Gr.5 PL	13
7	J65800-0083.01	Driveline Support - Long	1
8	159300-0979	Hex Bolt - 3/8" NC x 1-1/4" Gr.5 PL	1
9	159400-0018	Hex Bolt 3/8"NC x 5-1/2" Gr.5 PL	1
10	J40000-1027.00	PTO Hold Down Bar	1
11	168000-0049	Flat Washer - 3/8" USS PL	9
12	161500-0498	Quick Pin, 3/8" x 1-5/8"	1
13	159300-0590	Hex Bolt 1/4" NC x 2-1/2" Gr.5 PL	2
14	167200-0688	Nyloc Nut - 1/2" NC Gr.5 PL	19
15	159400-0007	Hex Bolt - 3/8" NC x 3-1/2" NC Gr.5 PL	1
16	J62800-0143.00	Body Weldment, RH, tail axle 2020	1
17	070000-0601	Hose Clamp Half	23
18	159400-0004	Hex Bolt - 3/8" NC x 2-1/2" Gr.5 PL	8
19	159400-0427	Hex Bolt - 1/2" NC x 2" Gr.5 PL	2
20	154000-0177	Toggle Clamp	2
21	168000-0022	Flat Washer - 1/4" USS PL	3
22	147100-0410	Rubber Bumper - 1-1/2"	1
23	159300-0544	Hex Bolt - 1/4" NC x 1" Gr.5 PL	1
24	J62800-0018.00	Access Door	1
25	159300-0543	Hex Bolt - 1/4" NC x 3/4" Gr.5 PL	10
26	147000-0010	Manual Canister	1
**	159300-0735	Hex Bolt - 5/16" NC x 1" Gr.5 PL	2
**	167200-0648	Nyloc Nut - 5/16" NC Gr.5 PL	2

11 PARTS

11.1 Frame Assembly

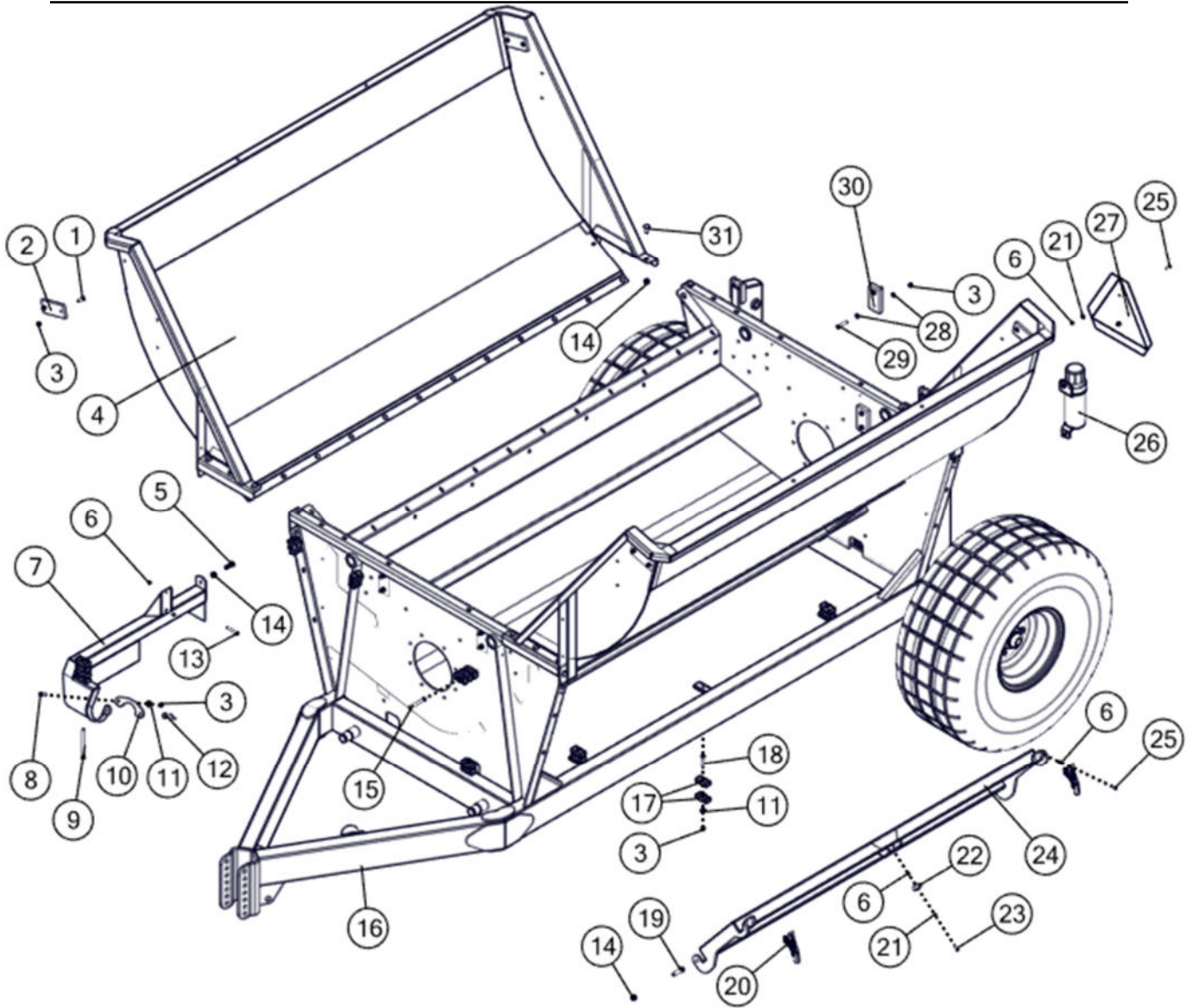

REF #	PART #	DESCRIPTION	QTY
27	147000-0004	Slow Moving Vehicle Emblem	1
28	168000-0540	Flat Washer - 3/8" SAE	20
29	159400-0003	Hex Bolt - 3/8" NC x 2" Gr.5 PL	8
30	147100-0290	Wear Pad	1
31	163100-0110	Carriage Bolt - 1/2" NC x 1-1/4" Gr. 5 PL	16

11 PARTS

11.1.1 Hitch Assembly

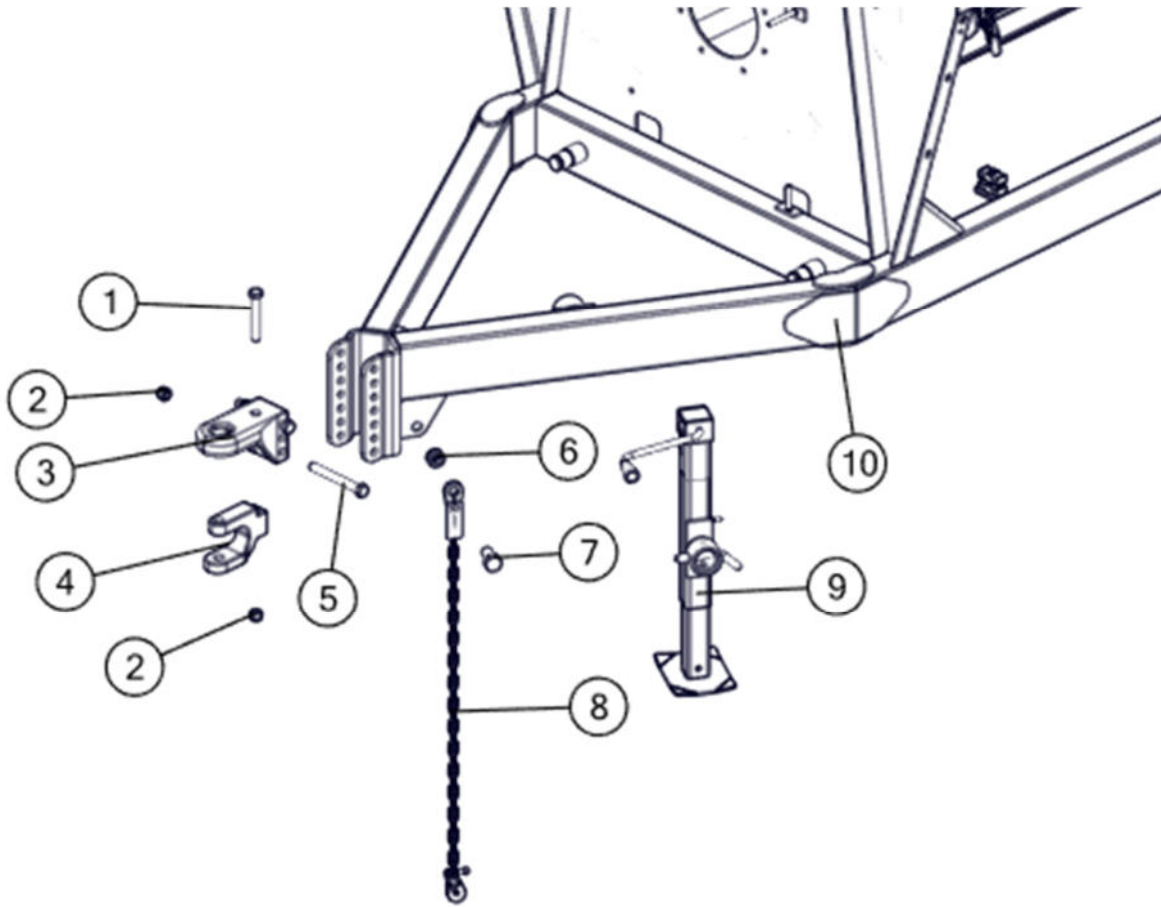

REF #	PART #	DESCRIPTION	QTY
1	159400-0815	Hex Bolt - 3/4" NC x 5" Gr.5 PL	1
2	167200-0692	Nyloc Nut - 3/4" NC Gr.5 PL	3
3	343000-0237	Base Hitch	1
4	343000-0206	Clevis	1
5	159400-0819	Hex Bolt - 3/4" NC x 6-1/2" Gr.5 PL	2
6	167200-0694	Nyloc Nut - 1" NC Gr.5 PL	1
7	159400-0970	Hex Bolt - 1" NC x 2" Gr.5 PL	1
8	140000-0490	Safety Chain	1
9	J62800-0141.00	Jack W/ Repad & Collar	1
10	J62800-0143.00	Body Weldment, RH, tail axle 2020	1

11 PARTS

11.1.2 Wheel and Hub Assembly

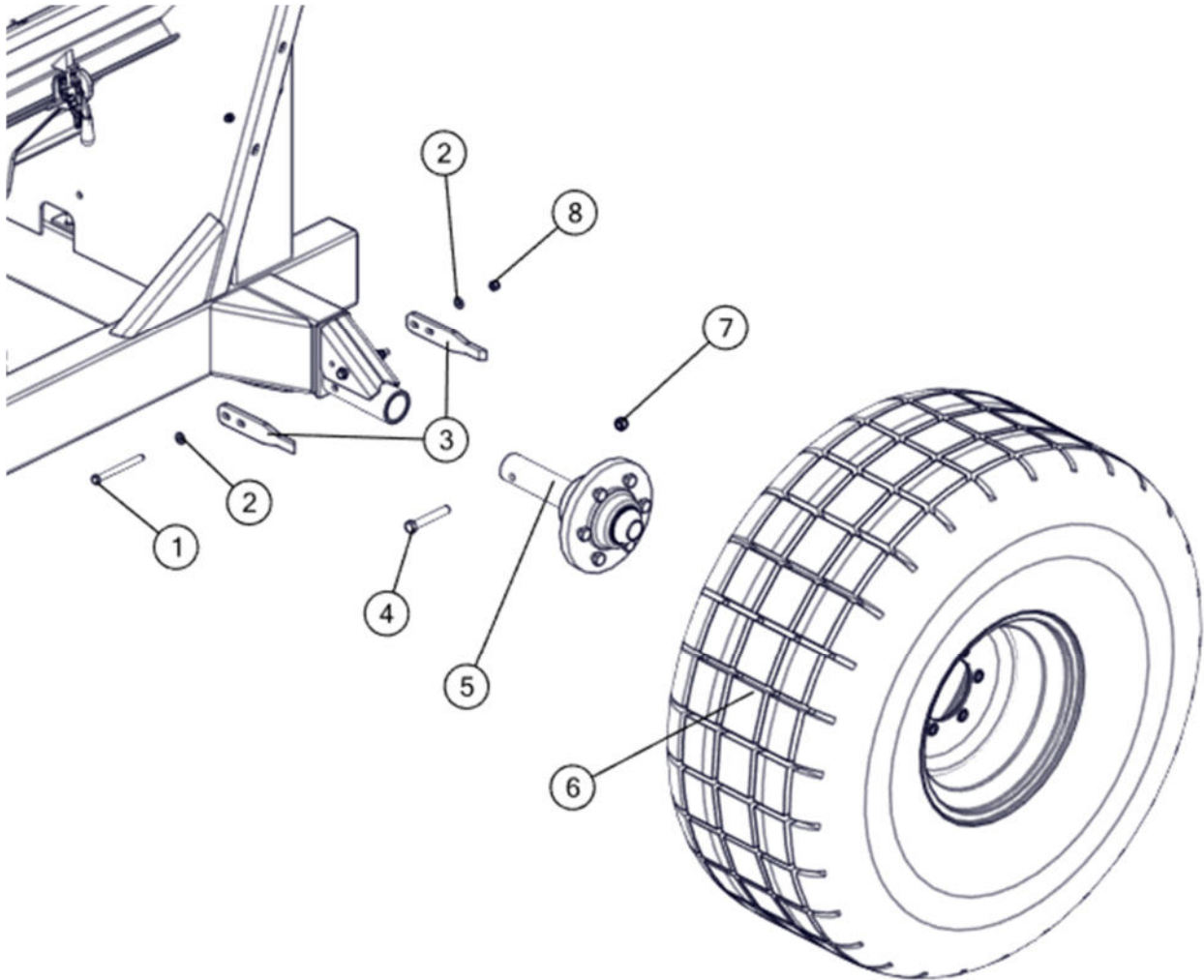

REF #	PART #	DESCRIPTION	QTY
1	159400-0015	Hex Bolt - 3/8" NC x 4-1/2" Gr.5 PL	4
2	168000-0540	Flat Washer - 3/8" SAE	8
3	J40000-0052.00	Hub Scraper	4
4	159400-0485	Hex Bolt - 1/2" NC x 3-1/2" Gr.5 PL	2
5	341000-0615	614 Hub and Spindle Complete	2
6	100100-0707	Tire & Rim 16.5L x 16.1SL x 14rim diamond tread	2
7	167200-0688	Nyloc Nut - 1/2" NC Gr.5 PL	2
8	167200-0652	Nyloc Nut - 3/8" NC Gr.5 PL	4

11 PARTS

11.1.3 Light Kit Assembly

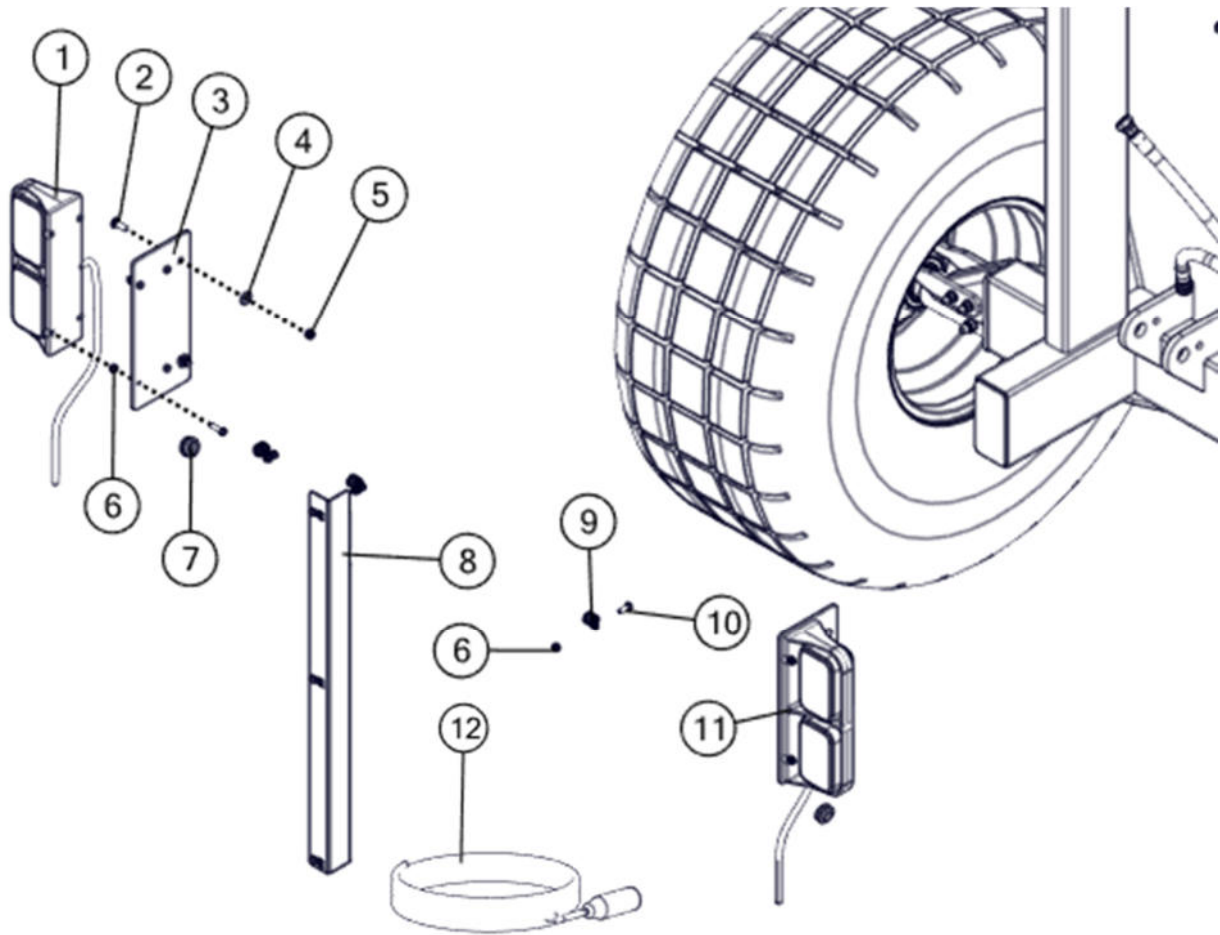

REF #	PART #	DESCRIPTION	QTY
1	147000-0600	LED Dual Tail Light Kit - Left	2
2	163000-0299	Carriage Bolt - 5/16" x 1" Gr.5 PL	4
3	J40000-1025.00	Light Mount Plate	2
4	168000-0040	Flat Washer - 5/16" USS PL	4
5	167200-0648	Nyloc Nut - 5/16" NC Gr.5 PL	4
6	167200-0642	Nyloc Nut - 1/4" NC Gr.5 PL	15
7	147100-0424	1" x .875" Rubber Grommet	2
8	J40000-1026.00	Light Cable Tray	1
9	147100-0430	RUBBER CUSION CABLE CLAMP	7
10	159300-0543	Hex Bolt - 1/4" NC x 3/4" Gr.5 PL	7
11	147000-0601	LED Dual Tail Light Kit - Right	1
12	147000-0616	Wire Harness 23' X 2' X 4'	1

11 PARTS

11.1.4 614 Hub Assembly

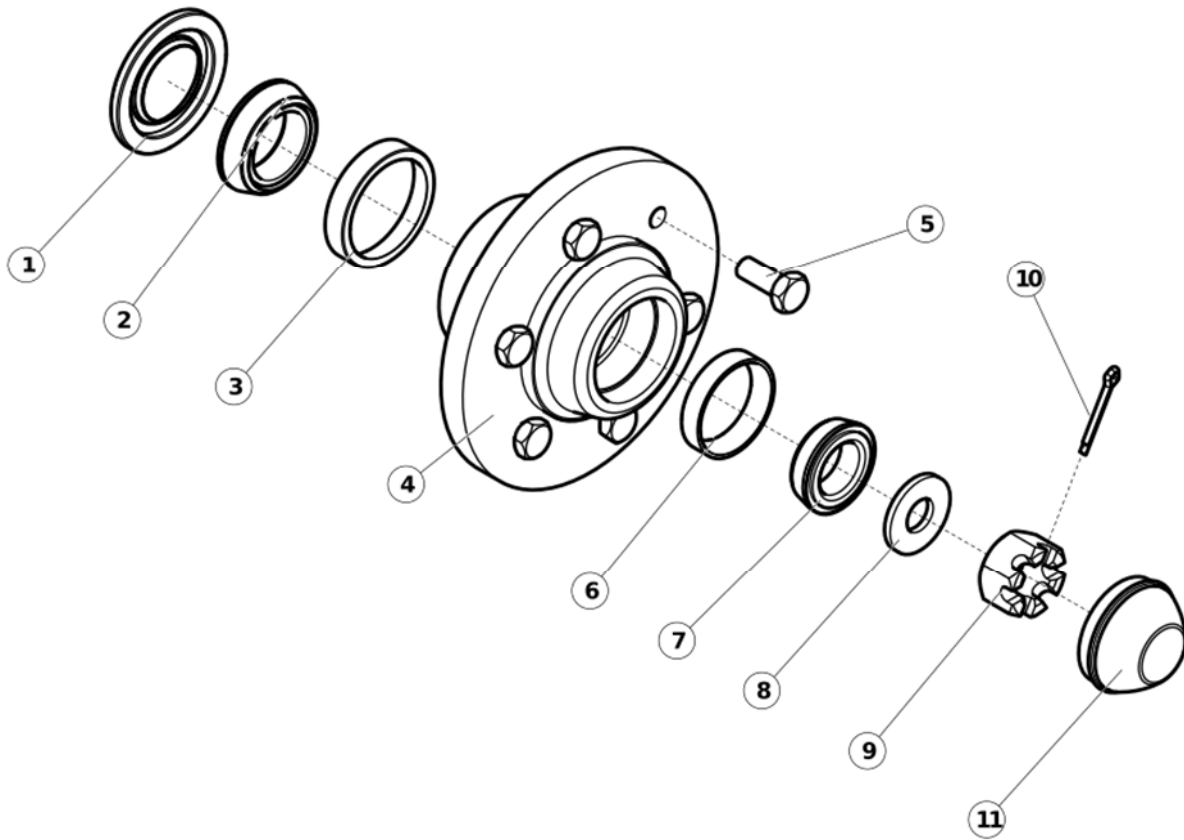

REF #	PART #	DESCRIPTION	QTY
1	340100-0016	Grease Seal - SE-16	1
2	114500-0135	Inner Cone - LM-603049	1
3	115000-0026	Inner Cup - LM-603011	1
4	340000-0614	614 Hub	1
5	340300-0012	Wheel Bolt - 9/16" - 18 NF x 1-1/4"	6
6	115000-0027	Outer Cup - LM-48510	1
7	114500-0022	Outer Cone - LM-48548	1
8	340700-0517	Spindle Washer 7/8" I.D., 2" O.D., 0.187" Thick	1
9	340700-0033	Spindle Nut - 1" x 14 UNF	1
10	170000-0190	Cotter Pin - 3/16" x 1.5"	1
11	340200-0015	Dust Cap - 2.72" x 1.45"	1

11 PARTS

11.2 Bale Cradle Assembly

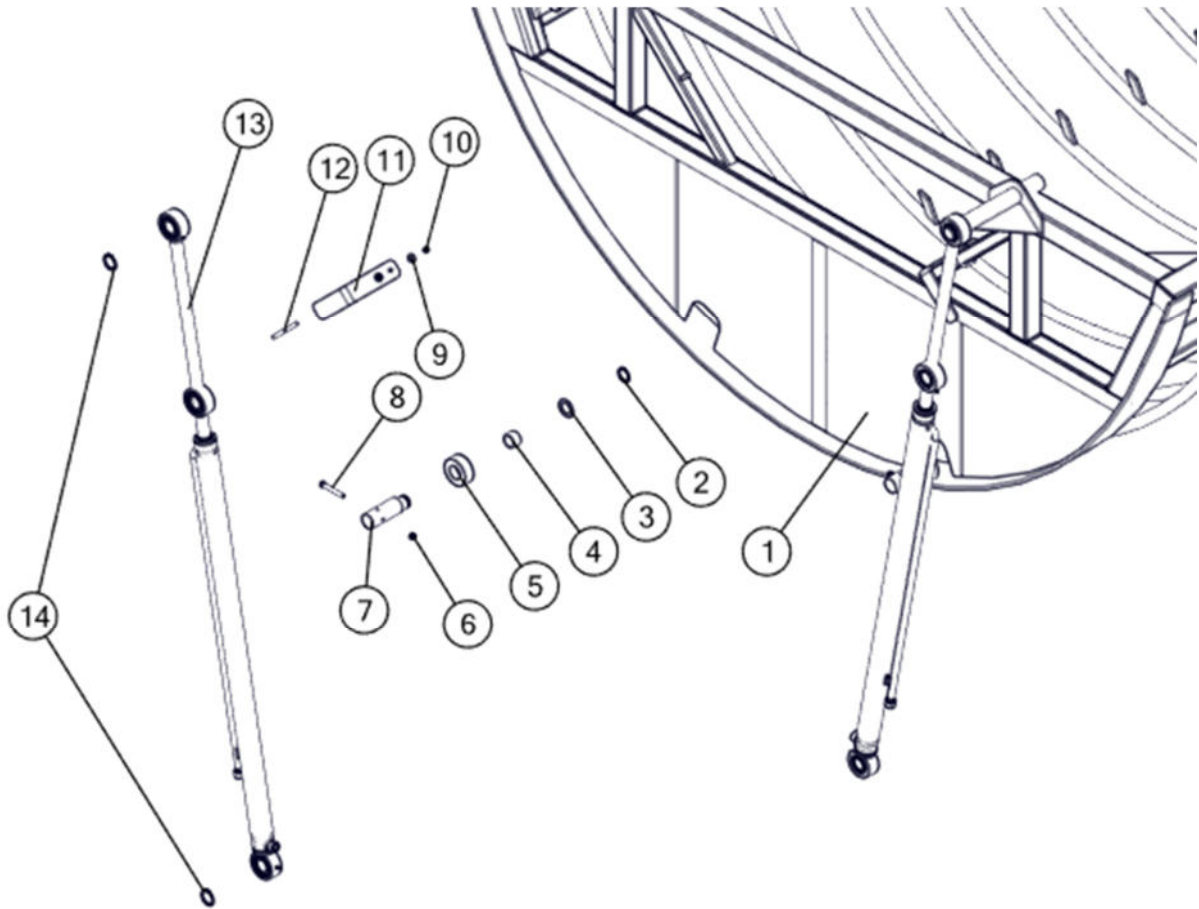

REF #	PART #	DESCRIPTION	QTY
1	J63800-0001.01	Bale Cradle Weldment	1
2	113900-0513	HD Snap Ring - 1-3/8" External	4
3	168000-0626	Machinery Bushing - 1-3/8" ID x 1-7/8" 14GA	4
4	113700-0001	Composite Bearing, 1-3/8" ID X 1-5/8" OD x 1"	4
5	066100-0104	Housing, Cradle Bearing, 3-1/4" x 1.25w	4
6	167200-0652	Nyloc Nut - 3/8" NC Gr.5 PL	4
7	066100-0005	Bale Cradle Bearing Pin	4
8	159400-0005	Hex Bolt - 3/8" NC x 3" Gr.5 PL	4
9	168000-0040	Flat Washer - 5/16" USS PL	4
10	167200-0648	Nyloc Nut - 5/16" NC Gr.5 PL	4
11	J40000-0177.00	Stroke Control	2
12	159000-0402	U-Bolt - 5/16" x 1-1/2" NC	2
13	107000-0202	Cradle Cylinder - SB427 2" x 46.25"	2
14	113900-0514	HD SNAP RING - 1-1/2" ID External	4

11 PARTS

11.3 Cradle Roller Assembly

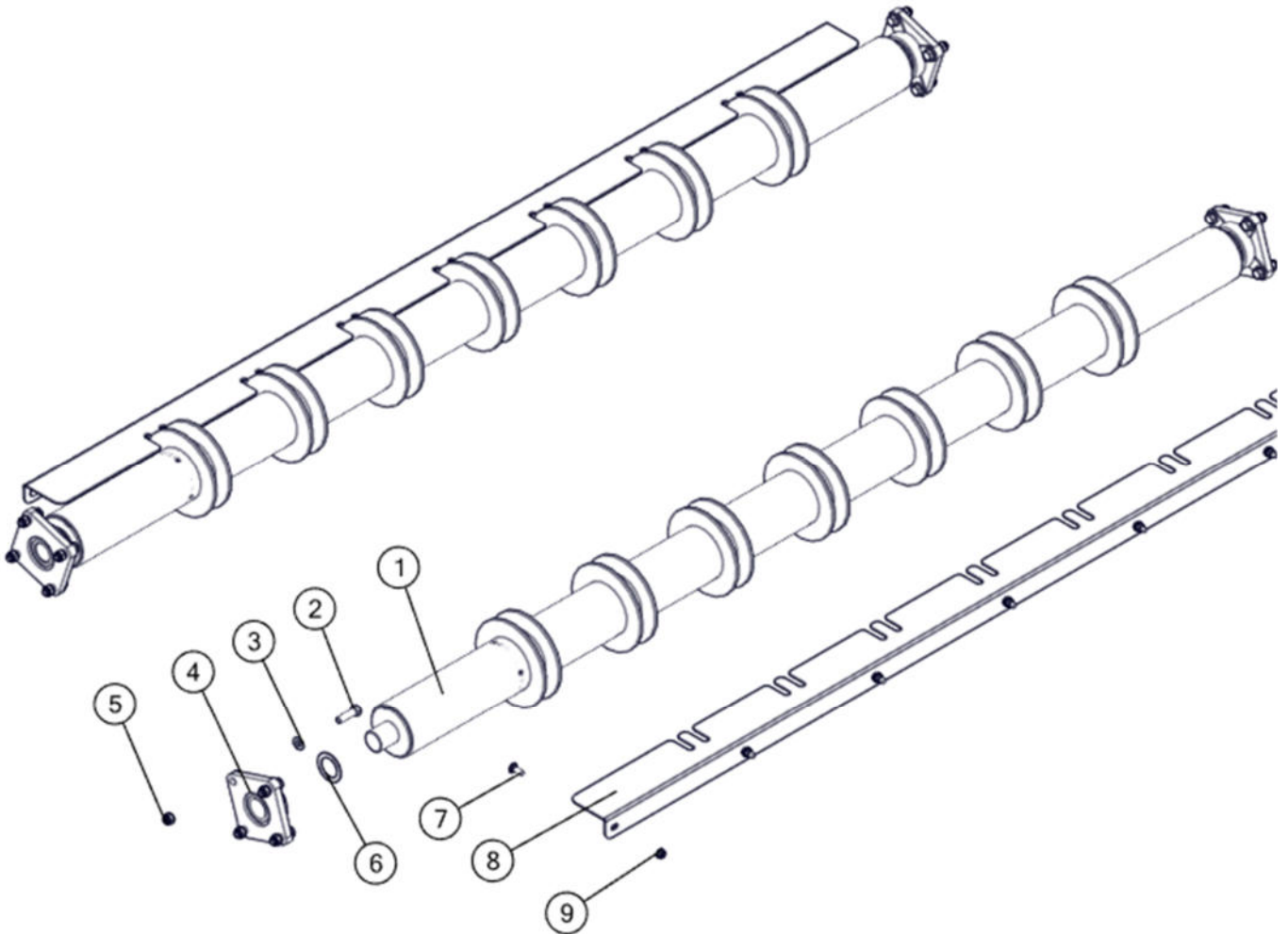

REF #	PART #	DESCRIPTION	QTY
1	J63800-0002.00	Cradle Roller Weldment	2
2	159400-0410	Hex Bolt - 1/2" NC x 1-3/4" Gr.5 PL	16
3	168000-0544	Flat Washer - 1/2" SAE PLTD	16
4	114000-0060	1-3/4" Bearing - 4 Bolt Flange Block	4
5	167200-0688	Nyloc Nut - 1/2" NC Gr.5 PL	16
6	168000-0631	Machinery Bushing - M40M	4
7	163000-0507	Carriage Bolt - 3/8" NC x 1" Gr.5 PL	14
8	J40000-1070.00	SHIELD, CRADLE ROLLER - Silage	2
9	167200-0510	Hex Nut - Flanged - 3/8" NC Gr.5 PL	14

11 PARTS

11.4 Drive and Rotor Assembly

REF #	PART #	DESCRIPTION	QTY
1	J63800-0003.00	Rotor Weldment, RH -silage	1
2	159400-0813	Hex Bolt - 3/4" NC x 4-1/4" Gr.5 PL	32
3	113300-0001	Hammer Bushing - Hardened	32
4	200600-0005	Hammer - 5-3/4" Reverse Curl x 5/8"	32
5	167200-0422	Top Lock Nut - 3/4" NC PL.	32
6	168000-0630	Machinery Bushing - M48H	2
7	159400-0485	Hex Bolt - 1/2" NC x 3-1/2" Gr.5 PL	1
8	J40000-0074.00	Lock Collar	1
9	167200-0688	Nyloc Nut - 1/2" NC Gr.5 PL	17
10	J40000-0070.01	Shaft Guard	1
11	167200-0690	Nyloc Nut - 5/8" NC Gr.5 PL	6
12	168000-0580	Flat Washer - 5/8" SAE PL	2
13	114000-0062	2" - 4-Bolt Flange Bearing	1
14	159400-0401	Hex Bolt - 1/2" NC x 1-1/2" Gr.5 PL	14
15	J62800-0014.00	Rotor Mount Weldment - Rear	1
16	J40000-0069.00	Twine Shield	4
17	168000-0066	Flat Washer - 1/2" Gr. 8	16
18	J62800-0047.00	Rotor Mount Weldment - Gear Drive	1
19	342100-0655	Star Gear Box	1
20	168600-0098	Lock Washer - 1/2" PL	4
21	159400-0515	Hex Bolt - 1/2" NC x 5-1/2" Gr5 PL	4
22	159500-0221	BOLT -HEX 3/8NC x 2 Gr8	2
23	167200-0412	Lock Nut - 3/8" NC	2
24	J62800-0048.00	Shield Weldment	1
25	170000-0200	Cotter Pin - 3/16" x 2"	1
**	066100-0008	Pin - PTO Shield	1
**	154000-0142	Overcenter Latch - 3.5"	1
26	159300-0515	Stove Bolt - 8-32 x 1/2"	2
27	167000-0519	Hex Nut - 8-32 PL	2
28	159400-0520	Hex Bolt - 1/2" NC x 6" Gr5 PL	2
29	375100-0001	PTO Shaft - Series 35 Weasler CAT 4	1
30	159400-0700	Hex Bolt - 5/8" NC x 3-1/2"	2

11 PARTS

11.4 Drive/Rotor Assembly

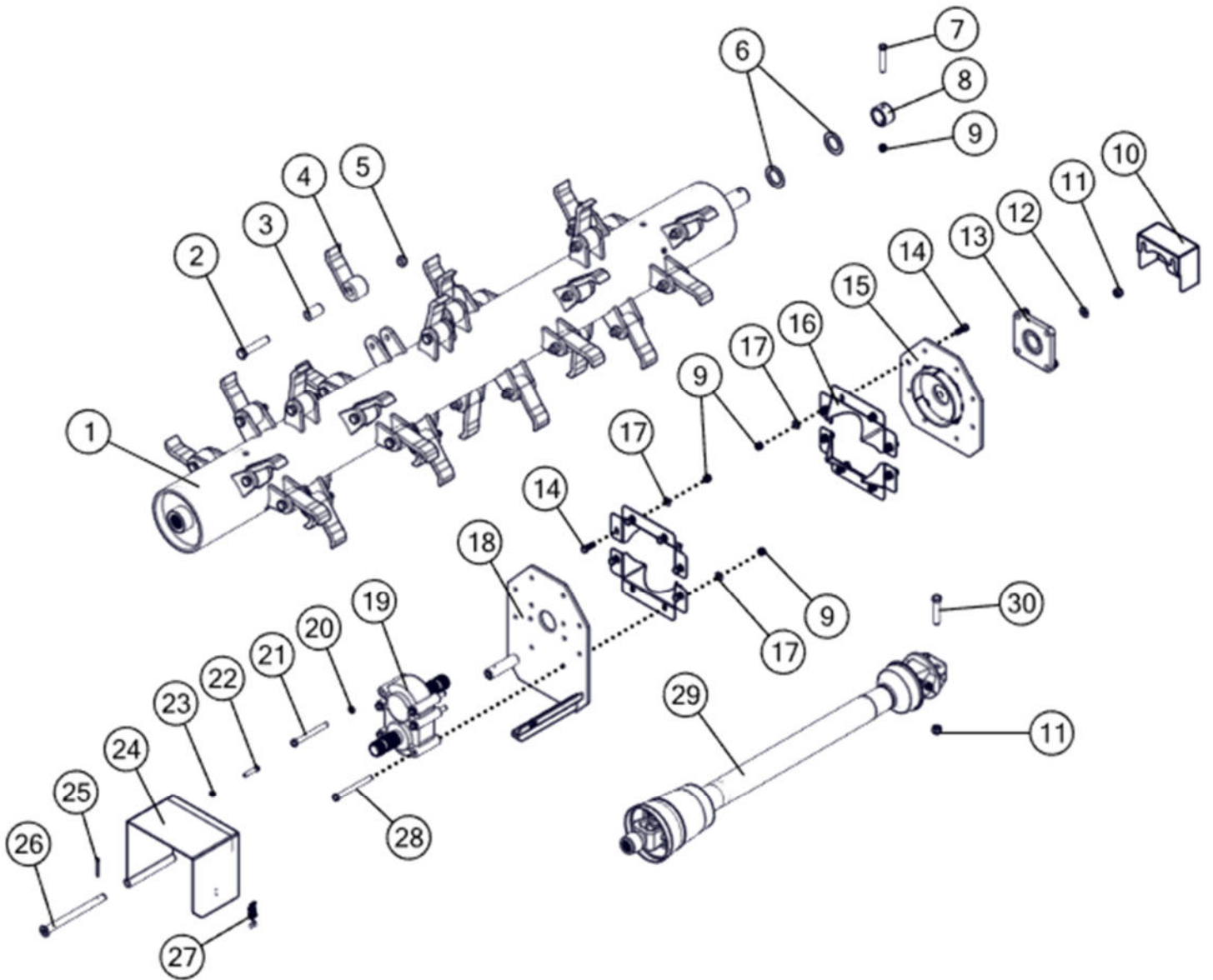

11 PARTS

11.5 Deflector Assembly

REF #	PART #	DESCRIPTION	QTY
1	J62800-0147.00	DEFLECTOR PLATE	1
2	J62800-0145.00	ANGLE ADJUSTER FRAME	1
3	167200-0688	Nyloc Nut - 1/2" NC Gr.5 PL	19
4	168000-0065	Flat Washer - 1/2" USS PLTD	6
5	159400-0401	Hex Bolt - 1/2" NC x 1-1/2" Gr.5 PL	2
6	154000-0174	1/2" SPRING LATCH	2
**	159300-0501	Stove Bolt - #10-24 x 5/8"	8
**	167000-0520	Hex Nut - #10-24 PL	8
7	066100-0032	5/8 x 3-1/4" PIN PLATED	1
8	159300-0979	Hex Bolt - 3/8" NC x 1-1/4" Gr.5 PL	1
9	167200-0652	5/8 x 3-1/4" PIN PLATED	1
10	167200-0689	Nyloc Nut 9/16" NC Gr.5 PL	2
11	159400-0543	BOLT-HEX, 9/16 X 4 NC GR5 PL	1
12	J40000-0122.00	Table Gusset - Right	1
13	145000-0015	Deflector Belting	1
14	J40000-0142.00	Inner Clamp Plate	2
15	157100-0800	SCREW, 10-24 X 1 WAFER TEK	36
16	159300-0735	Hex Bolt - 5/16" NC x 1" Gr.5 PL	8
17	J40000-0143.00	Clamp Angle	1
18	168000-0040	Flat Washer - 5/16" USS PL	12
19	167200-0648	Nyloc Nut - 5/16" NC Gr.5 PL	8
20	J62800-0027.00	Deflector Frame Weldment, RH	1
21	J62800-0026.00	Deflector Table Weldment, Right	1
22	159400-0485	Hex Bolt - 1/2" NC x 3-1/2" Gr.5 PL	4
23	168000-0544	Flat Washer - 1/2" SAE PLTD	10
24	J40000-0121.00	Table Gusset - Left	1
25	163100-0110	Carriage Bolt - 1/2" NC x 1-1/4" Gr. 5 PL	6
26	303200-0048	Extension Spring - 7"	1
27	159400-0460	Hex Bolt - 1/2" NC x 3" Gr.5 PL	1
28	159400-0430	Hex Bolt - 1/2" NC x 2-1/2" Gr.5 PL	6

11 PARTS

11.5 Deflector Assembly

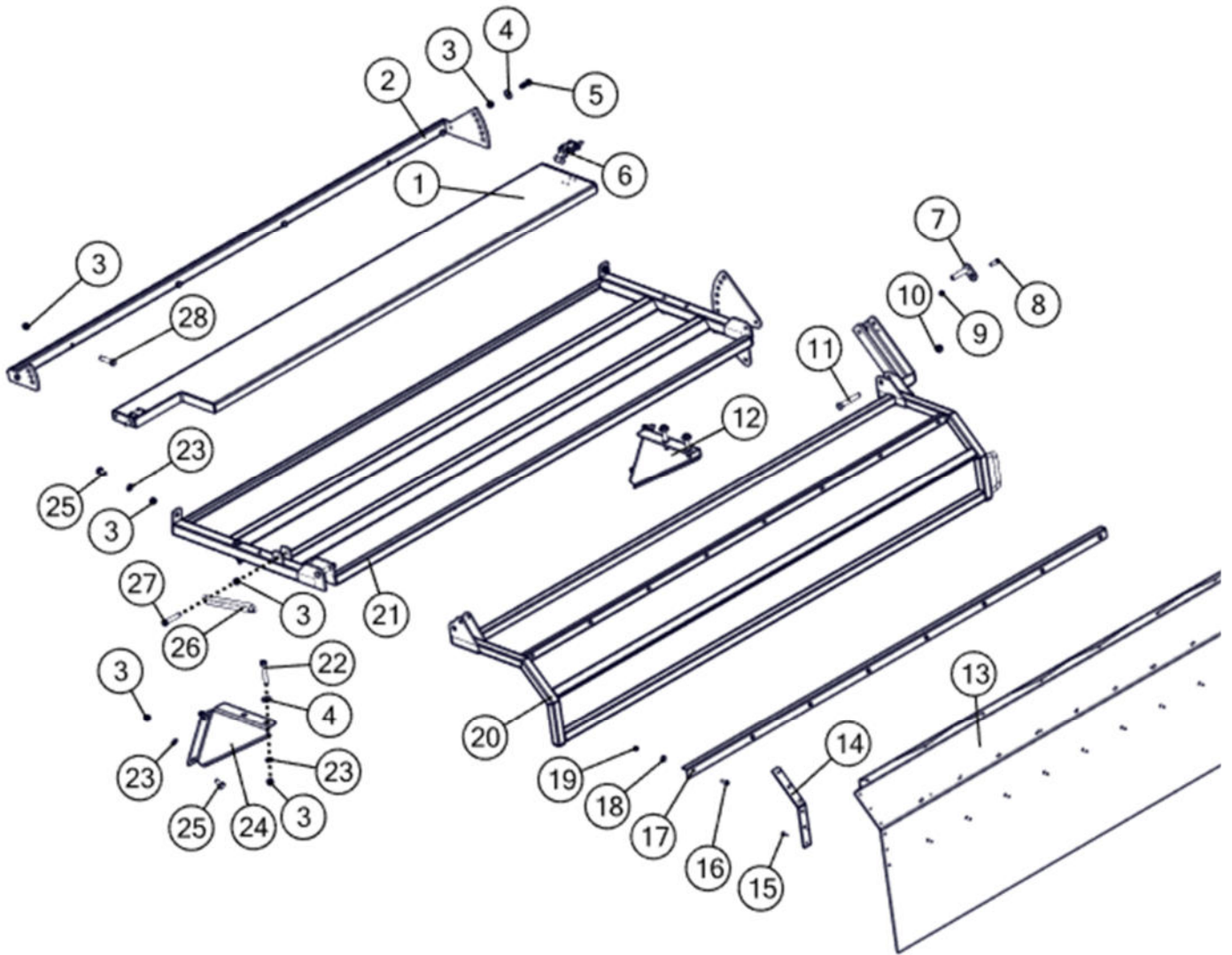

11 PARTS

11.6 Valve Shifter

REF #	PART #	DESCRIPTION	QTY
1	167200-0512	FLANGE NUT, 1/2	6
2	J62800-0022.00	Valve Plate Weldment	1
3	163100-0200	Carriage Bolt, 1/2 X 3 NC FULL TRD GR5 PL	2
4	167200-0652	Nyloc Nut - 3/8" NC Gr.5 PL	6
5	168000-0540	Flat Washer - 3/8" SAE	8
6	110100-0424	Single Spool Valve	1
7	159400-0003	Hex Bolt - 3/8" NC x 2" Gr.5 PL	3
8	163100-0110	Carriage Bolt - 1/2" NC x 1-1/4" Gr. 5 PL	2
9	066100-0007	Shifter Spool Weldment	1
10	113500-0060	BUSHING, 3/8 X 1/2 X 1 1/2 OILITE	2
11	303300-0437	Extension Spring, 15"	1
12	159400-0427	Hex Bolt - 1/2" NC x 2" Gr.5 PL	1
13	159400-0015	Hex Bolt - 3/8" NC x 4-1/2" Gr.5 PL	1
14	J62800-0024.01	Shift lever Weldment	1
15	172200-0791	Roll Pin 3/16" x 1"	1
16	168000-0544	Flat Washer - 1/2" SAE PLTD	3
17	167200-0688	Nyloc Nut - 1/2" NC Gr.5 PL	2
18	147100-0292	Guide, Shifter Spool	1
19	J40000-0103.01	Bearing Cover Plate	1
20	159400-0007	Hex Bolt - 3/8" NC x 3-1/2" NC Gr.5 PL	2

11 PARTS

11.6 Valve Shifter

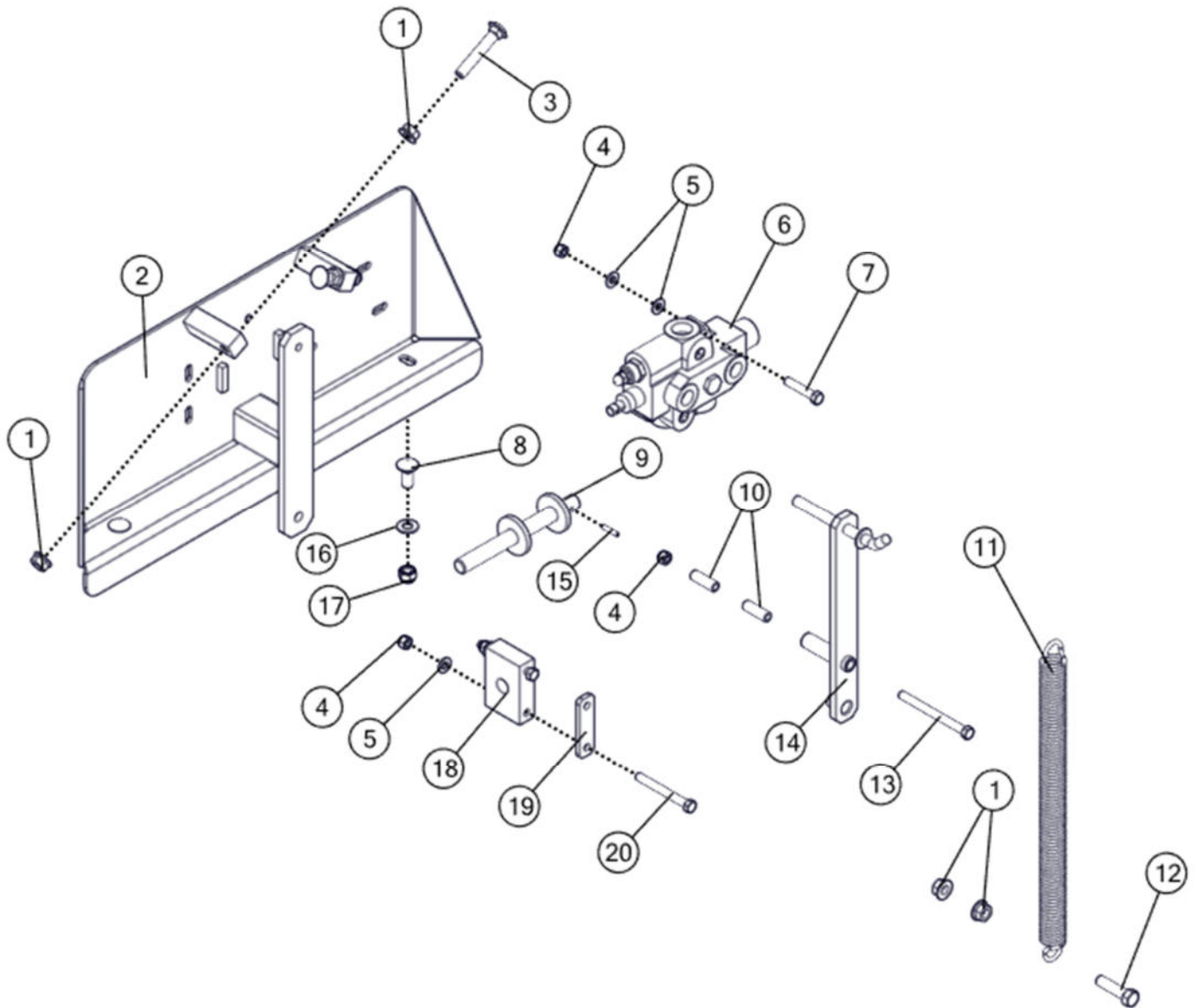

11 PARTS

11.7 Load Frame Assembly

REF #	PART #	DESCRIPTION	QTY
1	J63800-0006.01	Lift Frame Weldment	1
2	168000-0622	Machinery Bushing, 1-1/8" ID x 1-3/4" 10GA	2
3	170000-0270	COTTER PIN, 1/4" X 2"	2
4	066100-0003	Pin - Lift Frame	2
5	J63800-0007.00	Tine Mount Weldment	1
6	J62800-0041.00	Bale Tine Weldment - Right	1
7	167200-0695	Nyloc Nut 1-1/8" NC Gr.5 PL	2
8	J62800-0040.00	Bale Tine Weldment - Left	1
9	J62800-0131.00	Tine Retainer	2
10	J40000-1022.00	1-1/8 x 9" Grease Bolt	2
11	133200-0040	Grease Nipple - 1/8" NPT	2
12	167000-0836	Hex Nut - 3/4" NC Gr.8 PL	8
13	168600-0128	Lock Washer - 3/4" NC Gr. 8 PL	8
14	J63800-0008.00	Tine Mount Weldment	1
15	159000-0430	U-Bolt - 3/4" x 6-7/8" x 4-5/8"	4
16	066100-0002	Pin - Transport Lock	1
17	066100-0004	Pin - Lift Cylinder	4
18	107000-0203	Hydraulic Cylinder - 2-1/2" x 14-1/4"	2
19	167200-0652	Nyloc Nut - 3/8" NC Gr.5 PL	5
20	168000-0540	Flat Washer - 3/8" SAE	10
21	159300-0988	Hex Bolt - 3/8" NC x 1-1/2 Gr.5 PL	5
22	161300-0777	Hair Pin - 5/32" x 3-15/16"	1

11 PARTS

11.7 Load Frame Assembly

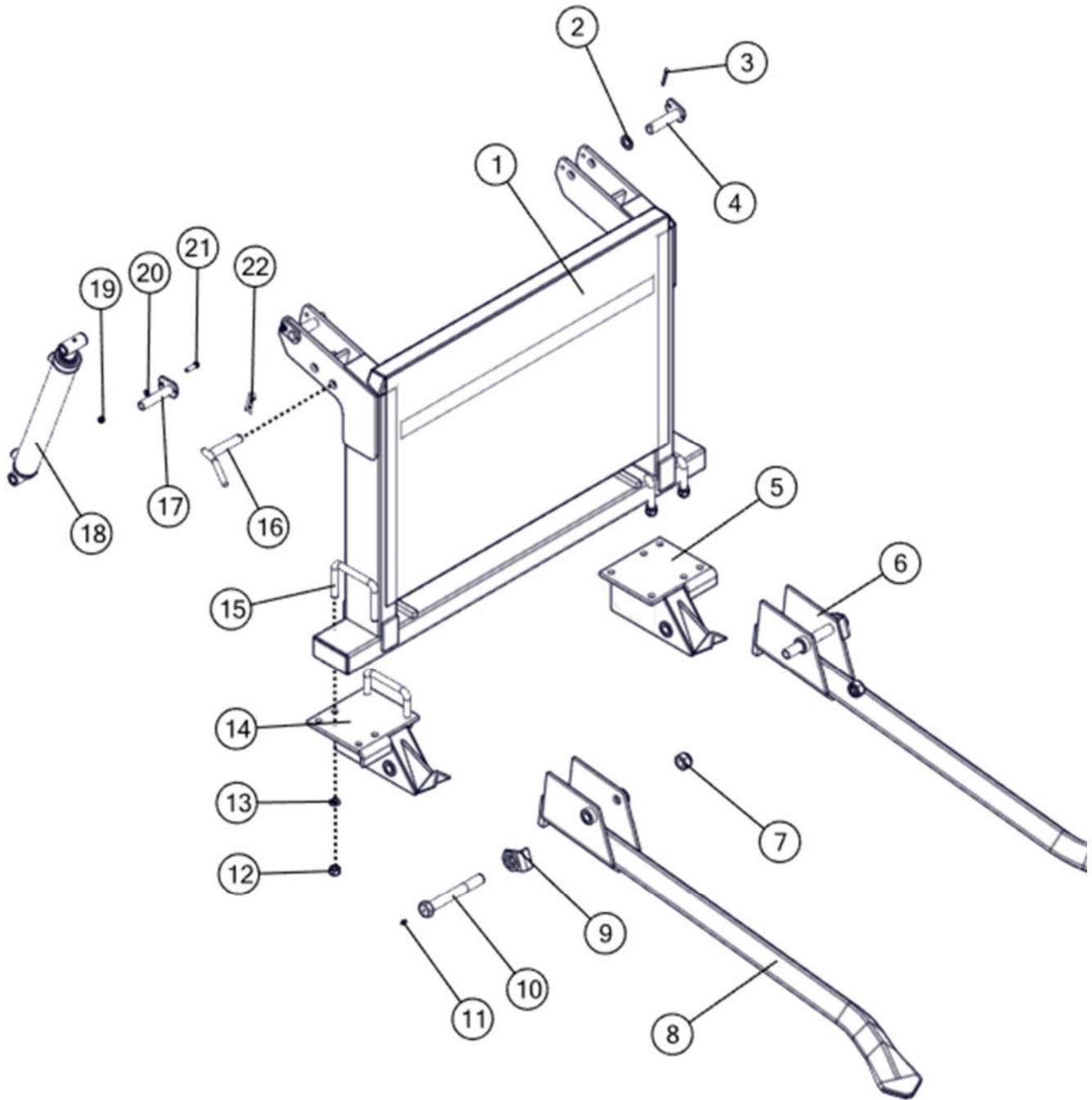

11 PARTS

11.8 Cradle Hydraulics

REF #	PART #	DESCRIPTION	QTY
1	104000-0610	Hydraulic - Q/C Male Poppet 1/2" FNPT	2
2	393500-0084	Hydraulic Hose - 1/2" x 84" x #8 JICF x 1/2" MPT	1
3	393500-0087	Hydraulic Hose - 1/2" x 87" x #8 JICF x 1/2" MPT	1
4	082400-0808	Hex Nipple - 1/2" MNPT x #8 JICM	1
5	111000-0204	Check Valve 1/2" MPT x 1/2" FPT	1
6	086500-0108	Coupler - 1/2" FPT x #8 JICF	1
7	085000-0307	Tee - #8 JICM x #8 JICM x #8 JICF (Drop)	1
8	086700-0809	Elbow 45° - #8 JICF x #8 JICM	1
9	086400-0808	Hex Nipple - #8 JICM x #8 ORBM	2
10	393400-0037	Hydraulic Hose - 3/8" x 27" x #8 JICF x #8 JICF	1
11	393400-0038	Hydraulic Hose - 3/8" x 38" x #8 JICF x #8 JICF 90°	1
12	085100-0908	Tee - #8 ORBM x #8 JICM x #8 JICM	2
13	393500-0058	Hydraulic Hose - 1/2" x 58" x #8 JICF x #8 JICF	1
14	086800-0912	Elbow 90° - #12 ORBM x #8 JICM	2
15	393500-0014	Hydraulic Hose - 1/2" x 14" x #8 JICF x #8 JICF	1
16	393500-0039	Hydraulic Hose - 1/2" x 39" x #8 JICF x #8 JICF	1
17	086800-0808	90° Elbow - #8 ORB x #8 JICM-sw	2
18	107000-0202	Cradle Cylinder - SB427 2" x 46.25"	2
19	110100-0424	Single Spool Valve	1
20	393500-0013	Hydraulic Hose - 1/2" x 13" x #8 JICF x #8 JICF	1
21	086800-0910	Elbow 90° - #10 ORBM x #8 JICM	1
22	110100-0398	Flow Control - FC51 1/2" NPT	1
23	086400-0812	Hex Nipple - #8 JICM x #10 ORBM	2

11 PARTS

11.8 Cradle Hydraulics

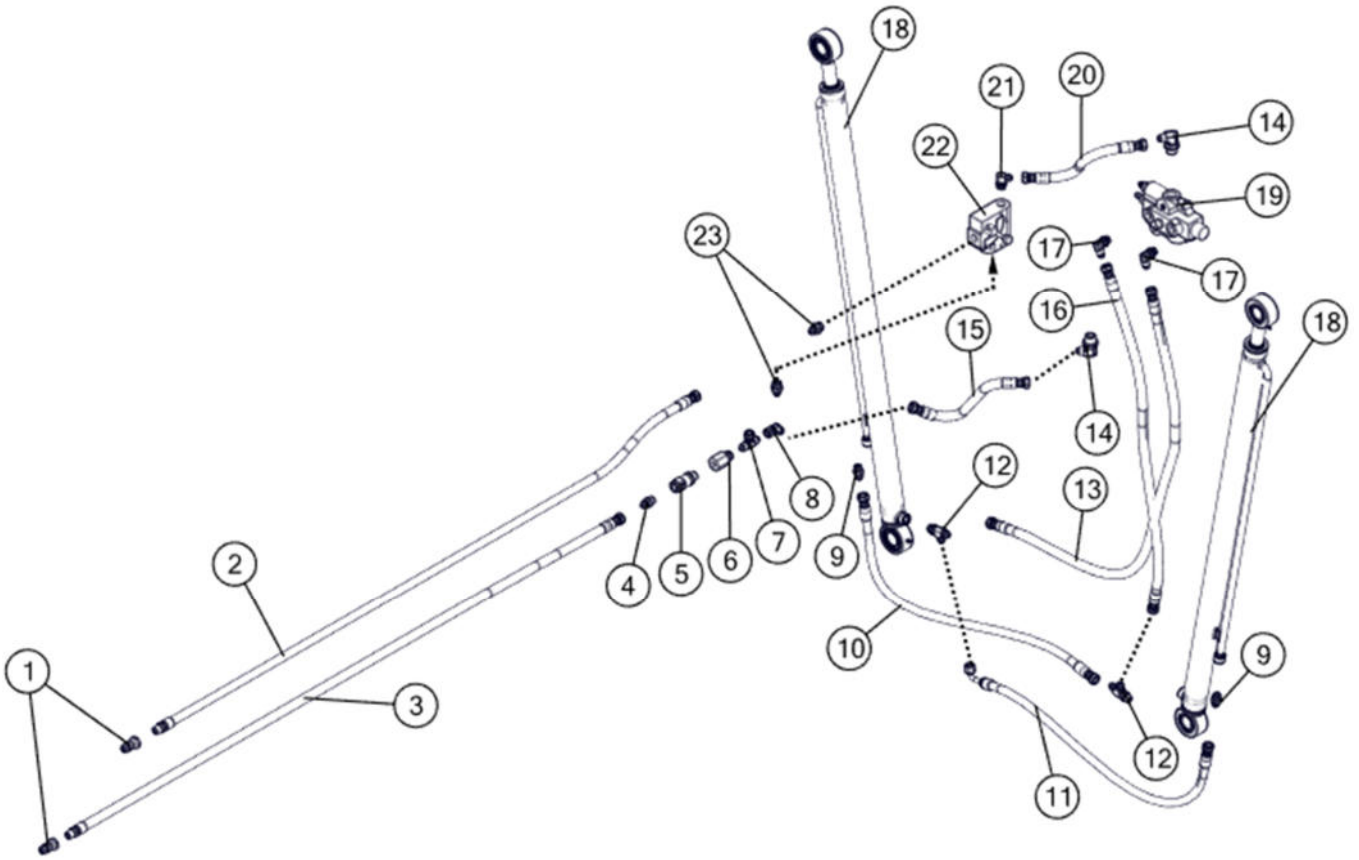

11 PARTS

11.9 Lift Cylinder Hydraulics

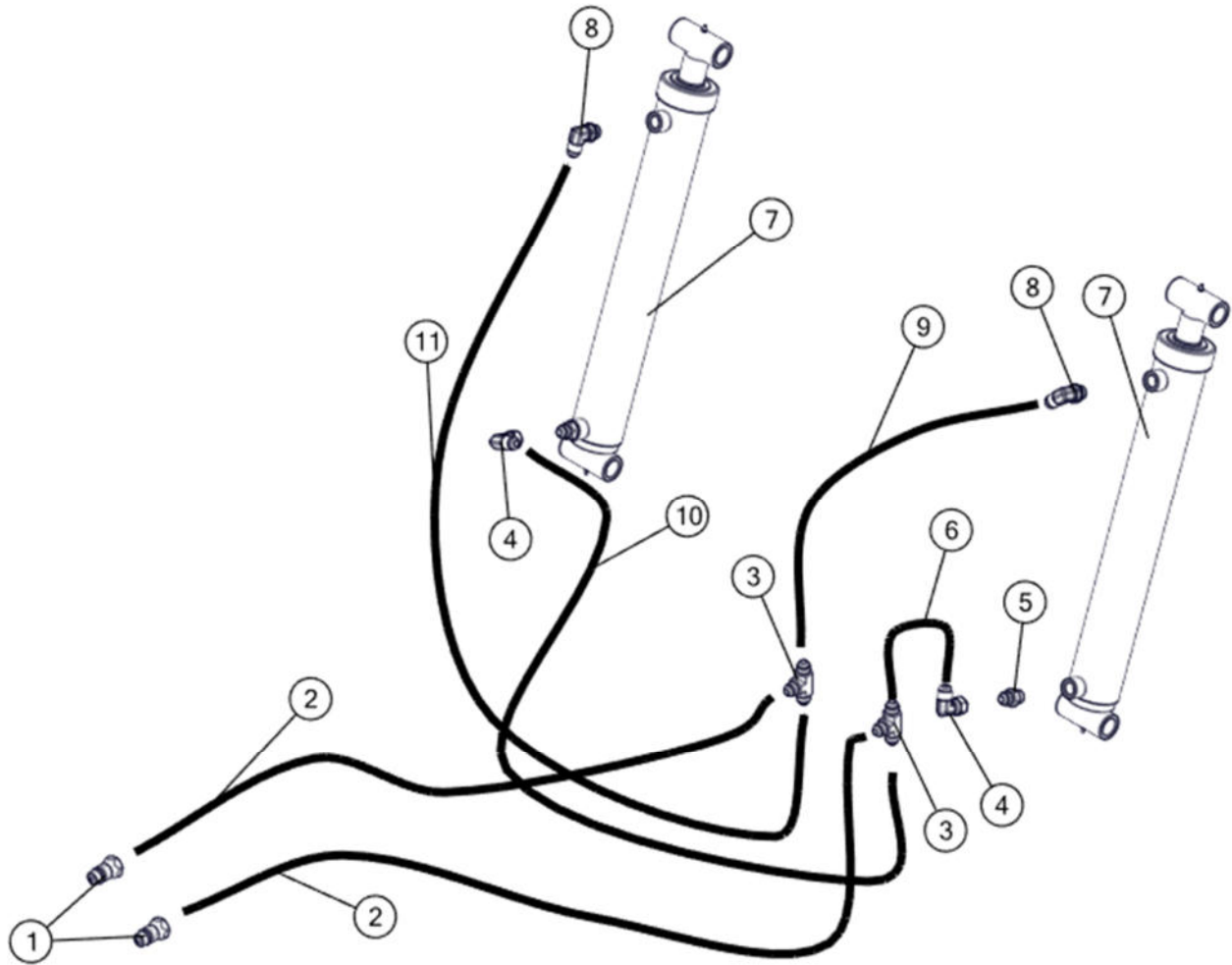

REF #	PART #	DESCRIPTION	QTY
1	104000-0610	Hydraulic - Q/C Male Poppet 1/2" FNPT	2
2	393500-0241	Hydraulic Hose - 1/2" x 241" x #8JICF x 1/2" MPT	2
3	085000-0308	Tee - #8 JICM x #8 JICM x #8 JICM	2
4	086800-0908	Elbow 90deg #8 JICM x #8 JICF-sw	2
5	081000-0108	Orifice Adapter - #8 ORBM x #8 JICM x .062"	2
6	393400-0018	Hydraulic Hose - 3/8" x 18" x #8 JICF x #8 JICF	1
7	107000-0203	Hydraulic Cylinder - 2-1/2" x 14-1/4"	2
8	086800-0808	90° Elbow - #8 ORB x #8 JICM-sw	2
9	393400-0021	Hydraulic Hose - 3/8" x 21" x #8 JICF x #8 JICF	1
10	393400-0029	Hydraulic Hose - 3/8" x 29" x #8 JICF x #8 JICF Long 90°	1
11	393400-0041	Hydraulic Hose - 3/8" x 41" x #8 JICF x #8 JICF 90°	1

**THIS PAGE INTENTIONALLY LEFT
BLANK**

11 PARTS

11.10 Deflector Hydraulic

REF #	PART #	DESCRIPTION	QTY
1	104000-0610	Hydraulic - Q/C Male Poppet 1/2" FNPT	2
2	393400-0149	3/8" 2w x 149" x #8 JICF x 1/2" MPT	1
3	081000-0107	Orifice Adapter - #8 ORBM x #8 JICM x .031"	1
4	167200-0652	Nyloc Nut - 3/8" NC Gr.5 PL	7
5	159300-0961	Hex Bolt - 3/8" NC x 1" Gr.5 PL	2
6	393400-0165	3/8" 2w x 165" x #8 JICF x 1/2" MPT	1
7	J40000-0964.01	Hose Tab - 3/8 HOLE	2
8	070000-0601	Hose Clamp Half	4
9	168000-0540	Flat Washer - 3/8" SAE	5
10	159400-0004	Hex Bolt - 3/8" NC x 2-1/2" Gr.5 PL	2
11	086800-0808	90° Elbow - #8 ORB x #8 JICM-sw	1
12	107000-0204	JSB472 DEFLECTOR CYLINDER 2" x 13.5" stroke	1
13	J62800-0043.00	Mount, Deflector Cylinder	1
14	159300-0979	Hex Bolt - 3/8" NC x 1-1/4" Gr.5 PL	3
15	066100-0033	5/8 x 3-11/16" PIN	1

11 PARTS

11.10 Deflector Hydraulics

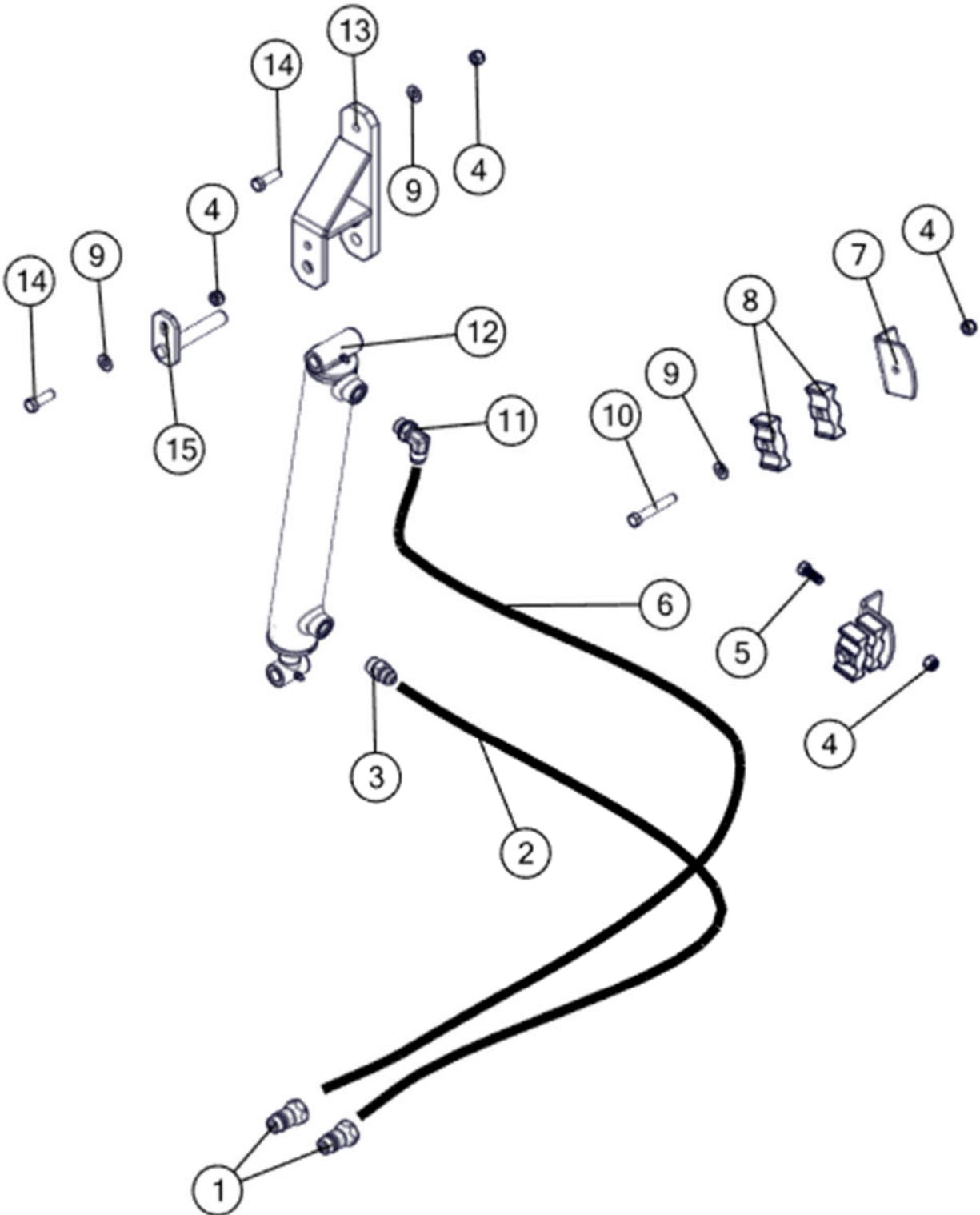



Printed in Canada