



Wood Chipper
BWC-040EC, BWC-040, BWC-060



Operator's Manual

Page left blank intentionally



TO THE DEALER:

Assembly and proper installation of this product is the responsibility of the Tar River dealer. Read manual instructions and safety rules. Make sure all items on the Dealer's Pre-Delivery and Delivery Check Lists in the Owner's/Operator's Manual are completed before releasing equipment to the owner.

TO THE OWNER:

Read this manual before operating your Tar River equipment. The information presented will prepare you to do a better and safer job. Keep this manual handy for ready reference. Require all operators to read this manual carefully and become acquainted with all the adjustment and operating procedures before attempting to operate. Replacement manuals can be obtained from your selling dealer. The equipment you have purchased has been carefully engineered and manufactured to provide dependable and satisfactory use. Like all mechanical products, it will require cleaning and upkeep. Lubricate the unit as specified. Observe all safety information in this manual and safety decals on the equipment. For service, your authorized Tar River dealer has trained mechanics, genuine Tar River service parts, and the necessary tools and equipment to handle all your needs. Use only genuine Tar River service parts. Substitute parts will void the warranty and may not meet standards required for safe and satisfactory operation.

Record your implement model and serial number in the space provide below. Your dealer will need this information to give you prompt, efficient service.

Model Number: _____

Serial Number: _____

Date Purchased: _____

Table of Contents

Introduction	5
Technical Specifications	5
Safety	6
Safety Signal Words	6
General Safety Guidelines	7
Safety Decal Care	7
Before Operation	8
During Operation	9
Highway And Transport Operations	10-11
Operating Instructions.....	12-16
Trouble Shooting	17
Torque Specifications	18
Parts Breakdown	21-30
BWC-040.....	22-23
BWC-060.....	24-25
BWC-040EC.....	26-29
BWC PTO Assembly.....	30
Decals	32-34
Warranty	35

Introduction

Thank you for purchasing your BWC Wood Chipper. It is important to properly maintain and keep in place all safety guards and shields that came with you machine.

The BWC Wood Chipper is the perfect tool to help clear your land of fallen limbs and branches. Use your wood chips to create beautifully covered flowerbeds and natural areas in the yard. Wood chips not only look nice, but they also help regulate soil temperature, retain moisture and even improve plant growth by helping release necessary nutrients into the soil.

Technical Specifications

- Shear pin PTO protection.
- 360 degree exit chute.
- 4 reversable blades made with hardened tool steel.
- Self-feed hopper.

	BWC-040EC	BWC-060
Weight	434 lbs.	785 lbs.
Req. HP	18-50	35-100
Chipping Capacity	4"	6"
Chipper Wheel	23.5" / 72 lbs.	32" / 187 lbs.
Discharge Hood Height	59"	73"

Important Safety Information

Safety

It is important that you read the entire manual and to become familiar with this product before you begin using it. This product is designed for certain applications only. The manufacturer cannot be responsible for issues arising from modification. We strongly recommend this product not be modified and /or used for any application other than that for which it is designed. If you have any questions relative to a particular application, DO NOT use the product until you have first contacted us to determine if it can or should be performed on the product.

Read and understand this manual and all safety signs before operating and maintaining . Review the safety instructions and precautions annually.

Safety Signal Words

TAKE NOTE! This safety alert symbol found though out this manual is used to call you attention to instructions involving you personal safety and the safety of others. Failure to follow these instructions can result in injury or death.



**This symbol means:
Attention!
Become alert!
Your safety is involved!**

Note the use of the signal words, DANGER, WARNING and CAUTION with the safety messages. The appropriate signal word for each has been selected using the following guidelines:



DANGER: Indicates an imminently hazardous situation that, if not avoided, will result in death or serious injury. This signal word is to be limited to the most extreme situations typically for machine components which, for functional purposes, cannot be guarded.



WARNING: Indicates a potentially hazardous situation that, if not avoided, could result in death or serious injury, and includes hazards that are exposed when guards are removed. It may also be used to alert against unsafe practices.



CAUTION: Indicates a potentially hazardous situation that, if not avoided, may result in minor or moderate injury. It may also be used to alert against unsafe practices.

Important Safety Information

General Safety Guidelines

Safety of the operator is one of the main concerns in designing and developing a new piece of equipment. Designers and manufacturers build in as many safety features as possible. However, every year many accidents occur which could have been avoided by a few seconds of thought and a more careful approach to handling equipment. You, the operator, can avoid many accidents by observing the following precautions in this section. To avoid personal injury, study the following precautions and insist those working with you, or for you, follow them.

Replace any DANGER, WARNING, CAUTION or instruction safety decal that is not readable or is missing. Location of such decals are indicated in this manual. Do not attempt to operate this equipment under the influence of drugs or alcohol.

Review the safety instructions with all users annually.

This equipment is dangerous to children and persons unfamiliar with its operation. The operator should be a responsible adult familiar with farm machinery and trained in this equipment's operations. **Do not allow persons to operate or assemble this unit until they have read this manual and have developed a thorough understanding of the safety precautions and of how it works.**

To prevent injury or death, use a tractor equipped with a Roll Over Protection System (ROPS). Do not paint over, remove or deface any signs or warning decals on your equipment. Observe all safety signs and practice the instructions on them.

Never exceed the limits of a piece of machinery. If its ability to do a job, or to do so safely, is in question - **Don't try it!**



Safety Decal Care

- Keep safety signs clean and legible at all times.
- Replace safety signs that are missing or have become illegible.
- Replaced parts that displayed a safety sign should also display the current safety sign
- Safety signs are available from your Distributor or Dealer Parts Department or the factory.

Important Safety Information

How to install Safety Signs:

- Be sure that the installation area is clean and dry.
- Decide on the exact position before you remove the backing paper.
- Remove the smallest portion of the split backing paper.
- Align the decal over the specified area and carefully press the small portion with the exposed sticky backing in place.
- Slowly peel back the remaining paper and carefully smooth the remaining portion of the decal in place.
- Small air pockets can be pierced with a pin and smoothed out using the piece of decal backing paper.



Before Operation

- Carefully study and understand this manual.
- Do not wear loose-fitting clothing, which may catch in moving parts.
- Always wear protective clothing and substantial shoes.
- Assure that all tires are inflated evenly.
- Give the unit a visual inspection for any loose bolts, worn parts or cracked welds, and make necessary repairs. Follow the maintenance safety instructions included with this manual.
- Be sure that there are no tools lying on or in the equipment.
- Do not use the unit until you are sure that the area is clear, especially of children and animals.
- Don't hurry the learning process or take the unit for granted. Ease into it and become familiar with your new equipment.
- Practice operation of your equipment and its attachments. Completely familiarize yourself and other operators with its operation before using.
- Use a tractor equipped with a Roll Over Protection System (ROPS) and fasten your seat belt prior to starting engine.
- The manufacturer does not recommend usage of tractor with ROPS removed.
- Move tractor wheels to the widest recommended settings to increase stability.
- Securely attach to towing unit. Use a high strength, appropriately sized hitch pin with a mechanical retainer and attach safety chain.
- Do not allow anyone to stand between the tongue or hitch and the towing vehicle when backing up to the equipment.
- Do not use the unit until you are sure that the area is clear, especially of children and animals.

Important Safety Information



During Operation

- Children should not be allowed on the product.
- Clear the area of small children and bystanders before moving the feeder.
- If using a towing unit, securely attach feeder by using a hardened 3/4" pin, a metal retainer, and safety chains if required. Shift towing unit to a lower gear before going down steep downgrades, thus using the engine as a retarding force. Keep towing vehicle in gear at all times. Slow down for corners and rough terrain.
- Make sure you are in compliance with all local and state regulations regarding transporting equipment on public roads and highways. Lights and slow moving signs must be clean and visible by overtaking or oncoming traffic when feeder is transported.
- Beware of bystanders, **particularly children!** Always look around to make sure that it is safe to start the engine of the towing vehicle or move the unit. This is particularly important with higher noise levels and quiet cabs, as you may not hear people shouting.
- **NO PASSENGERS ALLOWED!** Do not carry passengers anywhere on, or in, the tractor or equipment, except as required for operation.
- Keep hands and clothing clear of moving parts.
- Do not clean, lubricate or adjust your equipment while it is moving.
- When halting operation, even periodically, set the tractor or towing vehicle brakes, disengage the PTO, shut off the engine and **remove the ignition key.**
- Be especially observant of the operating area and terrain. Watch for holes, rocks or hidden hazards. Always inspect the area prior to operation.
- **DO NOT** operate near the edge of drop-offs or banks.
- **DO NOT** operate on steep slopes as overturns may result.
- Operate up and down (not across) intermediate slopes. Avoid sudden starts and stops.

Important Safety Information



Highway and Transport Operations

- Adopt safe driving practices.
- Keep the brake pedals latched together at all times. **Never use independent braking with machine in tow as loss of control and/or upset of unit can result.**
- Always drive at a safe speed relative to local conditions and ensure that your speed is low enough for an emergency stop to be safe and secure. Keep speed at a minimum.
- Reduce speed prior to turns to avoid the risk of overturning.
- Avoid sudden uphill turns on steep slopes.
- Always keep the tractor or towing vehicle in gear to provide engine braking when going downhill. Do not coast.
- Do not drink and drive!
- Comply with state and local laws governing highway safety and movement of farm machinery on public roads.
- Use approved accessory lighting flags and necessary warning devices to protect operators of other vehicles on the highway during daylight and nighttime transport. Various safety lights and devices are available from your dealer.
- The use of flashing amber lights is acceptable in most localities. However, some localities prohibit their use. Local laws should be checked for all highway and marking requirements.
- When driving the tractor and equipment on the road or highway under 40 kph (20 mph) at night or during the day, use the amber warning lights and a slow moving vehicle (SMV) identification emblem.
- Plan your route to avoid heavy traffic.
- Be a safe and courteous driver. Always yield to oncoming traffic in all situations, including narrow bridges, intersections, etc.
- Be observant of bridge loading ratings. Do not cross bridges rated at lower than the gross weight at which you are operating.
- Watch for obstructions overhead and to the side while transporting.
- Always operate in a position to provide maximum visibility at all times. Make allowances for increased length and weight of the equipment when making turns, stopping the unit, etc.
- Pick the most level route when transporting across fields. Avoid the edges of ditches or gullies and steep hillsides.
- Be extra careful when working in inclines.

Important Safety Information



Highway and Transport Operations

- Maneuver the tractor or towing vehicle at safe speeds.
- Avoid overhead wires or other obstacles. Contact with overhead lines could cause serious injury or death.
- Avoid loose fill, rocks and holes, they can be dangerous for equipment operation or movement.
- Allow for unit length when making turns,
- Operate the towing vehicle from the operator's seat only.
- Never stand alongside of unit with engine running or attempt to start engine and/or operate machine while standing alongside of unit.
- Never leave running equipment attachments unattended.
- As a precaution, always recheck the hardware on equipment following every 100 hours of operation. Correct all problems. Follow the maintenance safety procedures.

Operating Instructions

Operation

It is important that each operator of the Tar River Wood Chipper read and understand the operational procedures and all related safety precautions outlined in this section. The following pre-operation checklist is provided for the operator. It is important for both the personal safety and maintaining good mechanical condition that this checklist is followed.



Caution: Always wear personal protective equipment (PPE) whenever operating the machine. This includes but is not limited to protective shoes with slip resistant soles, protective goggles or face shield, heavy gloves, hearing protection and protective clothing.

Do not place metal, bottles, cans, rocks, glass or other solid material into the Wood Chipper. If something like this gets into the machine, stop the machine immediately for a detailed inspection. Stop engine, remove ignition key and place in your pocket and wait for all moving parts to stop before inspecting or unplugging. Inspect machine for damaged or loosened parts before resuming work.

Prior to operating the Wood Chipper:

1. Lubricate the machine per the schedule out-lined in the Maintenance Section.
2. Check the rotor, the blades and twig-breaker. Remove any twine, wire or other material that has become entangled.
3. Check the condition and clearance of the twig-breaker, the rotor and stationary blades. Adjust or replace as required.
4. Check that all bearings turn freely. Replace any that are rough or seized.
5. Make sure that all guards and shields are in place, secured and functioning as designed.
6. Check the condition of the curtain in the feed hopper. It must be in good condition to prevent chips from flying out.

Operating Instructions

Attaching the PTO shaft:

Before installing the PTO shaft make sure that the RPM rating and the direction of rotation match those of the tractor. Carefully read the PTO shaft and tractor instructions. Before operation, make sure that the guards are installed on the power take off of the tractor and PTO shaft. Make sure that they cover the PTO shaft throughout its length. Note: The PTO shaft may be too long and require shortening. See “**Shortening a PTO driveline**” below.

Press the locking pin on the PTO yoke and slide yoke on to the PTO of the tractor until the pin seats. Pull on PTO shaft to make certain it is locked in place. Repeat the procedure for the machine end. Attach the PTO cover’s safety chains to a stationary part of the tractor. Leave some slack in the chain to accommodate movement.

Shortening a PTO driveline:

1. With the machine attached to the tractor’s 3-point hitch, and the PTO shaft not installed, separate the PTO shaft. Attach the machine end to the machine and the other end to the tractor PTO input shaft.
2. Raise the machine by using the tractor’s hydraulic 3-point hitch to its maximum lift height.
3. Hold the half shafts next to each other and mark them so each end is approximately 1/2” from hitting the end of the telescopic profiles.
4. Shorten the inner and outer guard tubes equally.
5. Shorten the inner and outer profiles by the same length as the guard tubes. Using a rattail file, round off all sharp edges and burrs. Grease the telescopic profile generously before reassembling.

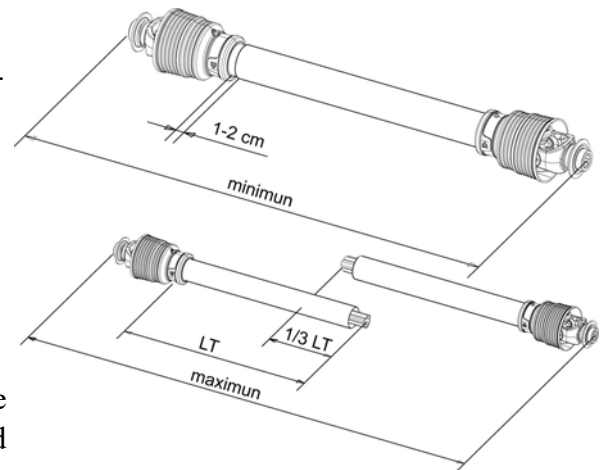

When fully extended, the tubes must overlap by at least 1/3 of the length of the pipes (LT). When retracted, the min. acceptable clearance is 1-2 cm (3/8”-3/4”)

Scan the QR code below for more detailed information on PTO installation.



Operating Instructions

Start up

Although there are no operational restrictions on the Wood Chipper when used for the first time, it is recommended that the following mechanical items be checked:

Maintenance Section

Before your first start and after operating for 1 hour and every 5 Hours of operation

- Torque all fasteners and hardware.
- Check condition of rotor bearings.
- Check the condition and clearance of the twig-breaker, rotor and stationary blades. Adjust or replace as required.
- Check for entangled material. Remove all entangled material before resuming work.
- Lubricate all grease fittings. See parts diagram for locations of grease fittings.

Starting the Machine

Start the tractor engine.

- Move the throttle to its low idle position.
- *With the engine at low idle, slowly engage the PTO control.*
- Slowly increase the engine speed until the PTO is at rated speed.
- With the manual feeding model, start feeding material into the hopper.

Stopping the Machine

- Stop feeding material into the hopper.
- Place the hydraulic feed control in off neutral.
- Slow engine RPM.
- Place hydraulic lever in its OFF position.
- Disengage PTO.
- Stop engine, remove ignition key and place in your pocket and wait for all moving parts to stop.

Adjustments

Deflector Position

Press down on the discharge pivot clamp to release the positioning pin. Swivel the chute to desired position. Adjust the Discharge Angle adjuster at the top of the chute.

Chip size

The anvil is mounted on the base with slotted holes. These holes allow the anvil to be moved in order to adjust the size of the chips you require

Operating Instructions

Feeding

The BWC may be available in either gravity or hydraulically feed.



Danger: If gravity feed be careful not to reach into the feed hopper further than the curtain. To reach further, use a stick or branch to push any material into the disc that does not go in on its own. To begin operations, slowly slide the material to be chipped into the hopper. Allow it to feed on its own without exerting much pressure.

Plugging

If plugging occurs, following these procedures:

- Stop the engine, remove the ignition key and place it in your pocket and wait for all moving parts to stop before unplugging.
- Pull the material out of the **feed hopper**. Be sure all the material is cleaned out and nothing is jammed or wedged between the input opening and the rotor.
- Pull the material out of the discharge hood. Use a stick to loosen any material jammed into the **discharge hood**. Do not allow anything to remain in this area.

If severe plugging occurs:



Danger: Ensure the engine is off and you have pocked the key to prevent unintentional startup.

- Loosen the feed hopper anchor nuts and raise the feed hopper. Remove material from inside the rotor compartment.
- Clean out the discharge area/rotor.
- Open the **rotor cover** and clean out the housing. Be sure to turn the rotor by hand to be sure there is nothing jammed between the rotor and stationary blades.
- Close, install and fold down all components opened to unplug. Tighten fasteners to their specified torque.
- Check that everyone is clear of machine before restarting engine.
- Start the engine, engage the PTO and resume working.

Sharpening Blades:

The rotor blades and anvil need to be sharp for the chipper to perform as expected. It is recommended that the rotor blades be removed from the rotor when sharpening. Always sharpen the blades at a 45° angle to provide the best cutting effect as it meets the anvil. Be sure to tighten the blade mounting bolts to their specified torque when re-installing the blades to the rotor.

Operating Instructions

The stationary blade is designed with 4 sharp corners that can be utilized. When the corner facing the rotor blade rounds over, remove the blade and re-install with a different corner facing the rotor blade. Use the anvil to set the clearance to the rotor blade when re-installing. Be sure to tighten mounting bolts to their specified torque.

The drive system is designed to function well without failing the shear pin. If it does fail, generally it is being fed too fast or something very hard has been jammed into the rotor or between the blades. Always unplug the system and determine the cause of the problem and correct it before resuming work

Anvil/Blade Clearance:

It is recommended that the clearance between the rotor and anvil be set and maintained at 1/32 to 1/16 inch to obtain the best performance. Use the stationary blade mounting bolts to set the clearance as required.

Twig Breaker:



Caution: Clear the area of bystanders, especially small children.

Stop the engine, remove the ignition key and place it in your pocket and wait for all moving parts to stop before unplugging.

Pull the material out of the feed hopper. Be sure all the material is cleaned out and nothing is jammed or wedged between the input opening and the rotor.

Pull the material out of the discharge hood. Use a stick to loosen any material jammed into the **discharge hood**. Do not allow anything to remain in this area.

Trouble Shooting

PROBLEM	CAUSE	SOLUTION
Rotor not turning.	Obstructed discharge.	Shut down and clear debris.
	Rotor plugged.	Clear rotor.
	Broken shear pin.	Replace shear pin.
Slow feeding.	Knives are dull.	Sharpen knives.
	Blade angle wrong, improper angle.	Re-sharpen knives to specified angle.
	Discharge hood clogged.	Clear discharge hood.
Chipper requires excessive power or stalls.	Obstructed discharge. Rotor plugged.	Clear discharge hood. Clear rotor.
	Green material will not discharge. Dull knives.	Allow material to dry or alternately feed in dry material. Sharpen knives.
High power required	Plugged rotor.	Clear rotor.
	Dull knives.	Sharpen knives.
Vibration while running.	Drive line vibration.	Check drive line phasing. yokes must be aligned.
		Check rotor to see if it wobbles. Check to see if rotor is assembled correctly.
Drive belts slipping or smoking.	Loose or worn belts.	Adjust or replace belts.
	Plugged rotor.	Clear rotor.

Torque Specifications for Common Bolt Sizes															
Inches		Bolt Head Identification						Metric		Bolt Head Identification					
										5.8		8.8		10.9	
Bolt size (inches)	Thread pitch	Grade 2		Grade 5		Grade 8		Class 5.8		Class 8.8		Class 10.9			
		N.m	ft-lb	N.m	ft-lb	N.m	ft-lb	N.m	ft-lb	N.m	ft-lb	N.m	ft-lb		
1/4"	20	7	5	11	8	16	12	M5	0.08	4	3	6	4	9	7
1/4"	28	8	6	13	10	19	14	M6	1	6	4	10	7	15	11
5/16"	18	15	11	24	17	33	25	M8	1.25	16	12	25	18	36	27
5/16"	24	17	13	26	19	37	27	M8	1	17	13	26	19	38	28
3/8"	16	27	20	42	31	59	44	M10	1.5	31	23	48	35	71	52
3/8"	24	31	23	47	35	67	49	M10	1.25	33	24	51	38	75	55
7/16"	14	43	32	67	49	95	70	M10	1	35	26	53	39	78	58
7/16"	20	48	36	75	55	106	78	M12	1.75	54	40	84	62	123	91
1/2"	13	66	48	102	75	144	106	M12	1.5	56	41	87	64	128	94
1/2"	20	75	55	115	85	163	120	M12	1.25	59	44	90	66	133	98
9/16"	12	95	70	147	109	208	154	M14	2	84	62	133	98	195	144
9/16"	18	106	79	164	121	232	171	M14	1.5	94	69	142	105	209	154
5/8"	11	132	97	203	150	287	212	M16	2	131	97	206	152	302	223
5/8"	18	149	110	230	170	325	240	M16	1.5	141	104	218	161	320	236
3/4"	10	233	172	361	266	509	376	M18	2.5	181	133	295	218	421	310
3/4"	16	261	192	403	297	569	420	M18	2	196	145	311	229	443	327
7/8"	9	226	167	582	430	822	606	M18	1.5	203	150	327	241	465	343
7/8"	14	249	184	642	473	906	668	M20	2.5	256	189	415	306	592	437
1"	8	339	250	873	644	1232	909	M20	1.5	288	212	454	335	646	476
1"	12	371	273	955	704	1348	995	M22	2.5	344	254	567	418	807	595
1-1/8"	7	480	354	1077	794	1746	1288	M22	1.5	381	281	613	452	873	644
1-1/8"	12	539	397	1208	891	1958	1445	M24	3	444	327	714	526	1017	750
1-1/4"	7	677	500	1519	1120	2463	1817	M24	2	488	360	769	567	1095	808
1-1/4"	12	750	553	1682	1241	2728	2012	M27	3	656	484	1050	774	1496	1103
1-3/8"	6	888	655	1992	1469	3230	2382	M27	2	719	530	1119	825	1594	1176
1-3/8"	12	1011	746	2268	1673	3677	2712	M30	3.5	906	668	1420	1047	2033	1499
1-1/2"	6	1179	869	2643	1949	4286	3161	M30	2	1000	738	1600	1180	2250	1659
1-1/2"	12	1326	978	2974	2194	4823	3557	M36	4	1534	1131	2482	1830	3535	2607

Notes:

This chart is an approximate estimate of torque values.

Always tighten hardware to these values unless a different torque value or tightening procedure is listed for a specific application.

Fasteners must always be replaced with the same grade as specified in the manual.

Always use the proper tool for tightening hardware: SAE for SAE hardware and Metric for Metric hardware.

Make sure that fastener threads are clean and that you properly start thread engagement.

Page left blank intentionally

Page left blank intentionally



Wood Chipper
BCW-040EC, BCW-040, BCW-060



Parts Manual

BWC-040

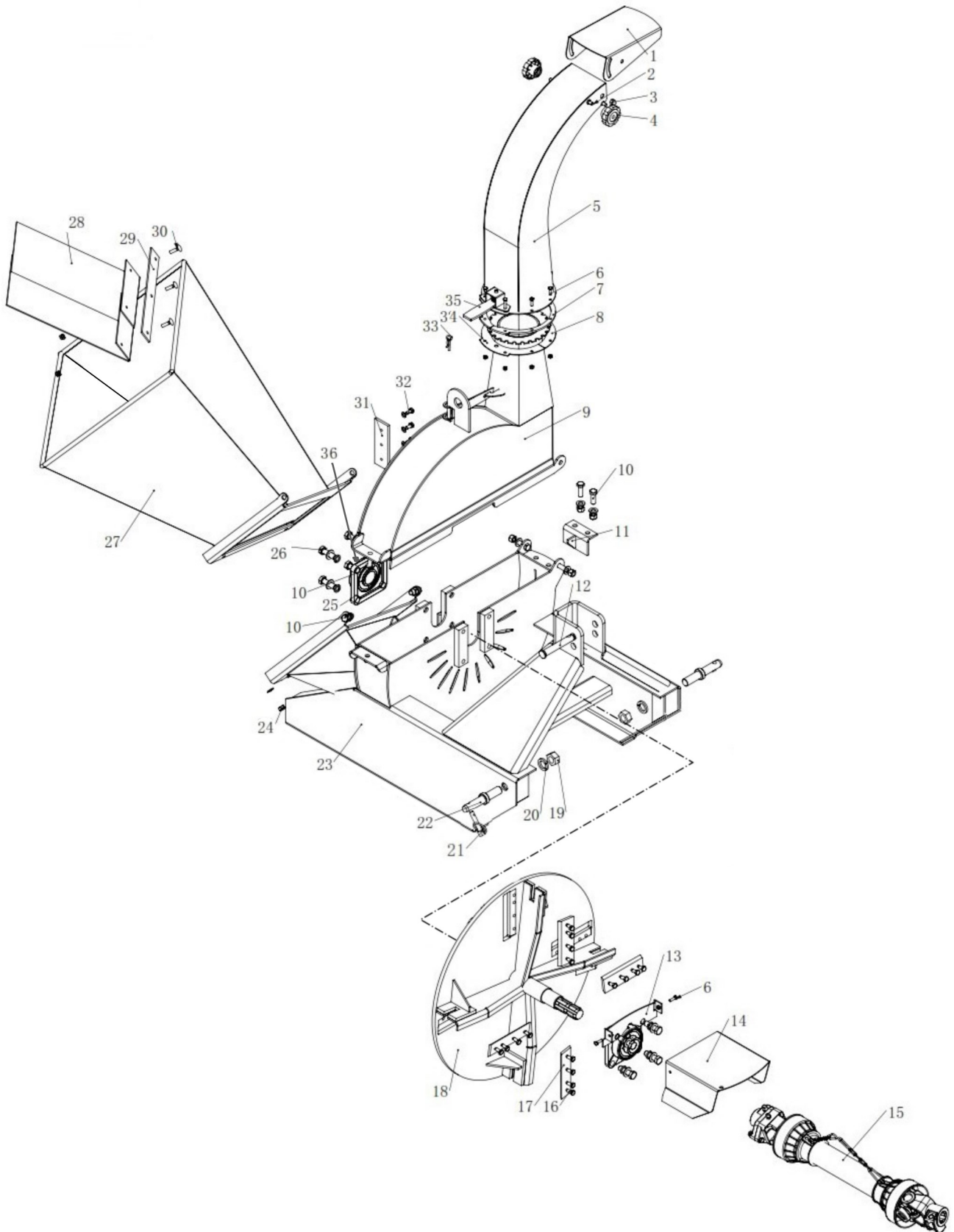

BWC-040

Item	Part #	Description	Qty.
1	BX4-0601	Deflector	1
2	SSM0812530	Socket screw M08-1.25x30	4
3	NM08125	Nut- M08-1.25	2
4	BX4-9313	Knob - deflector	2
5	BX4-0600	Discharge chute	1
6	BM061020	Bolt HH M06-1.00x10	10
7	BX4-0605	Spacer ring	2
8	BX4-0603	Ring - fastener rear	1
9	BX4-0501	Disc housing - upper disc	1
10	BM1212535	Bolt HH M12-1.75x35	7
11	BX4-0207	Latch	1
12	BX4-0801	Top link pin	1
13	BX4-0402	Bracket - input shaft	1
14	BX4-0401	Shield for PTO	1
15	147200	PTO complete	1
16	SSM0812530	Socket screw M08-1.25x30	16
	LNLM08125	Nut self locking M08-1.25	16
17	BX4-0201	Blade	4
18	BX4-0102	Disc	1
19	NM2215	Nut HH M22-1.50	2
20	LW22	Washer lock M22	2
21	LYNPN10	Lynch pin	2
22	BX4-0701	Hitch pin Cat. 1	2
23	BX4-0300	Frame	1
24	LNMPN10	Nut elastic stop M12-1.75	2
25	BUCF208	Bearing UCF208	2
26	BM142045	Bolt HH M14-2.00x45	8
27	BX4-0101	Chute	1
28	BX4-0308	Flap	2
29	BX4-9004	Support - flap	1
30	BM0812530	Bolt HH M08-1.25x30	3
31	BX4-9003	Anvil	1
32	BM081016	Bolt HH M08-1.00x16	3
33	RC3	R-clip M03	1
34	BX4-0604	Ring - fastener latch	1
35	BX4-9007	Latch	1
36	GN061S	Grease nipple M06-1.00 straight	2

BWC-060

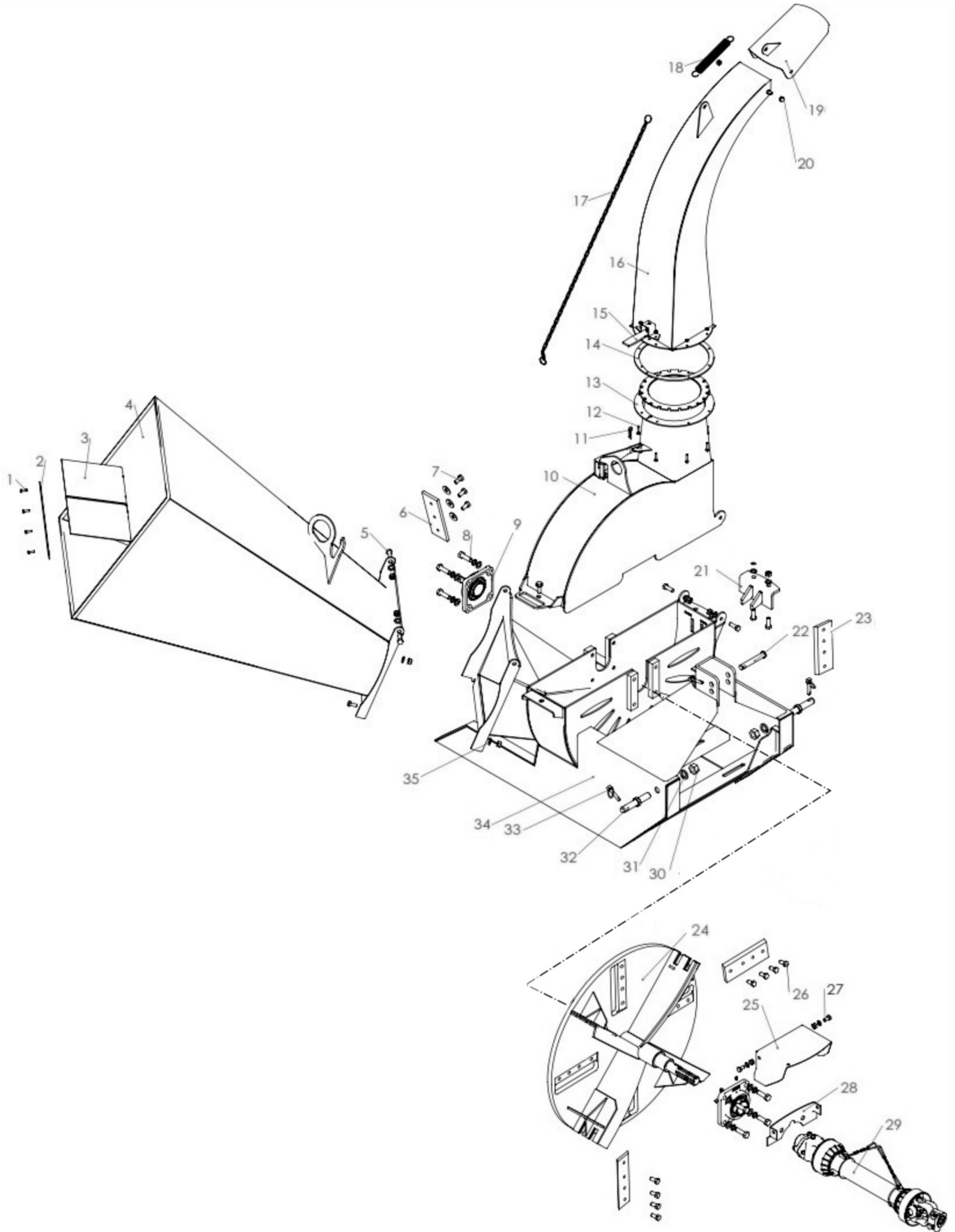

BWC-060

Item	Part #	Description	Qty.
1	BM061020	Bolt HH M06-1.00x20	4
2	BX6-0607	Support - flap	1
3	BX6-0903	Flap	2
4	BX6-0101	Chute	1
5	BM1217535	Bolt HH M12-1.75x35	7
6	BX6-0901	Anvil	1
7	BM121525	Bolt HH M12-1.50x25	3
8	BM142045	Bolt HH M14-2.00x45	8
9	BUCF210	Bearing UFC 210	2
10	BX6-0301	Disc housing - upper disc	1
11	RC3	R-clip M03	1
12	BM061030	Bolt HH M06-1.00x30	8
13	BX6-0203	Ring - fastener rear	2
14	BX6-0204	Spacer ring	2
15	BX6-0602	Latch	1
16	BX6-0902	Discharge chute	1
17	BX6-0202	Chain	1
18	BX6-0201	Spring	1
19	BX6-0905	Deflector	1
20	CAPNM1015	Nut cap M10-1.50	2
21	BX6-0103	Twig breaker	1
22	BX4-0801	Top link pin	1
23	BX6-0401	Blade	4
24	BX6-0904	Disc	1
25	BX6-R0101	PTO shield	1
26	SSM1217525	Socket screw M12-1.75x25	16
	LN12175	Self-locking nut M12-1.75	16
27	BM101520	Bolt HH M10-1.50x20	2
28	BX6-0102	Back plate shield PTO	1
29	147200	PTO complete	1
30	NM2215	Nut M22-1.50	2
31	LW22	Washer lock M22	2
32	BX4-0701	Hitch pin Cat. 1	2
33	LYNPN10	Lynch pin	2
33	BX6-0511	Frame	1
34	FW10	Flat washer M10	2
35	GN061S	Grease nipple M06-1.00	2

BWC-040EC Discharge Chute

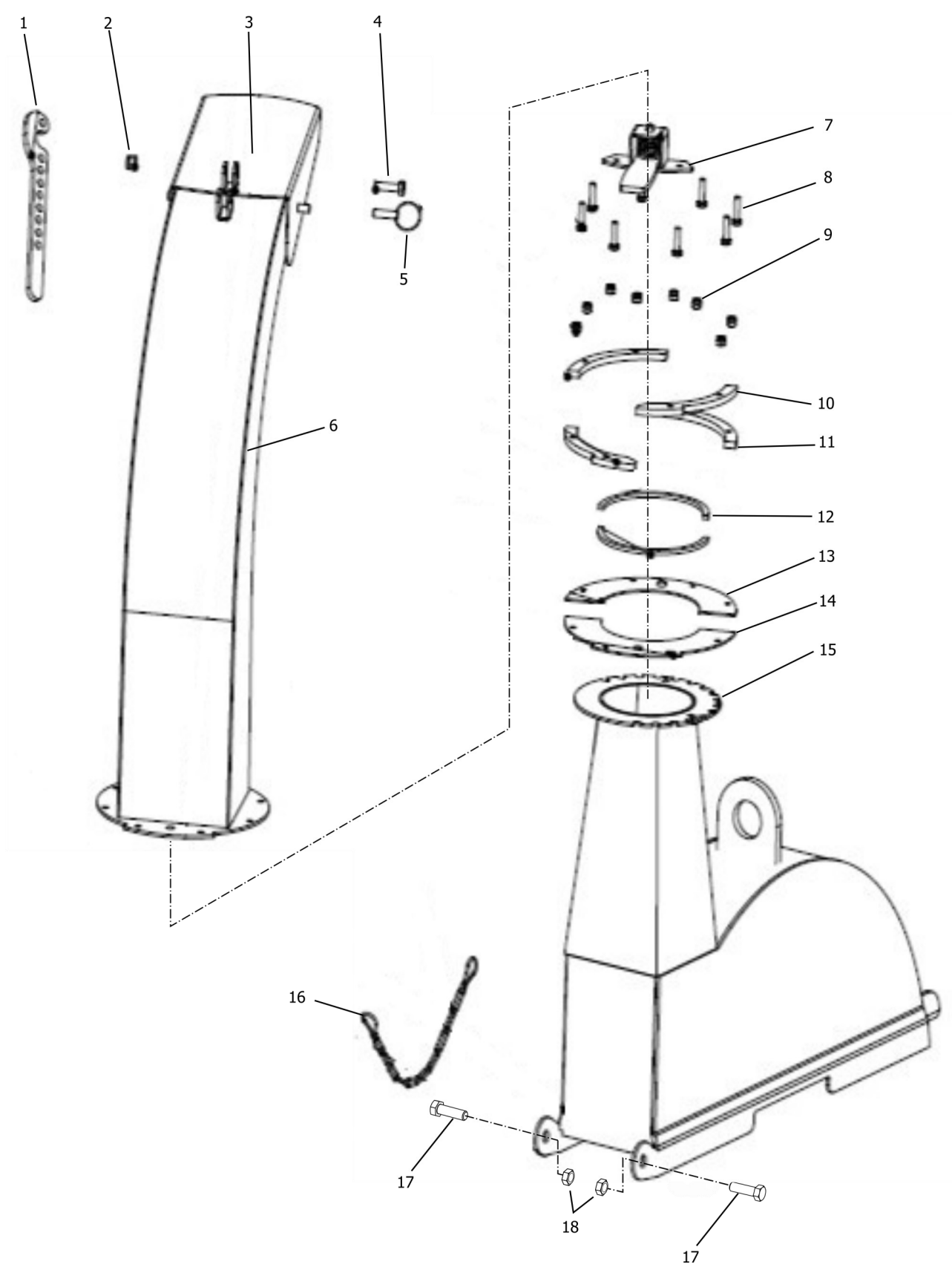

BWC-040EC Discharge Chute

Item	Part #	Description	Qty.
1	BX52G-03-01	Discharge latch	1
2	LNLM08125	Locking nut M08-1.25	1
3	BX52G-01-+	Chute deflector	1
4	BM0812530	Bolt HH M08-1.25x30	1
5	BX52G-01	Discharge chute	1
6	BX4-0007	Latch assembly	1
7	BM061030	Bolt HH M06-1.00x30	8
8	LNLM0610	Nut lock M06-1.00	8
9	BX52G-03-10	Spacer ring 2	1
10	BX52G-03-09	Spacer ring 1	1
11	BX52G-05-06	Half round plate 2	1
12	BX52G-03-08	Half round plate 1	1
13	BX52G-05-02-02	Upper rotor housing	1
14	BX52G-05-01-11	PTO chain	1
15	BM1217525	Bolt HH M12-1.75x25	2
16	LNLM12175	Locking nut M12-1.75	2

BWC-040EC Frame

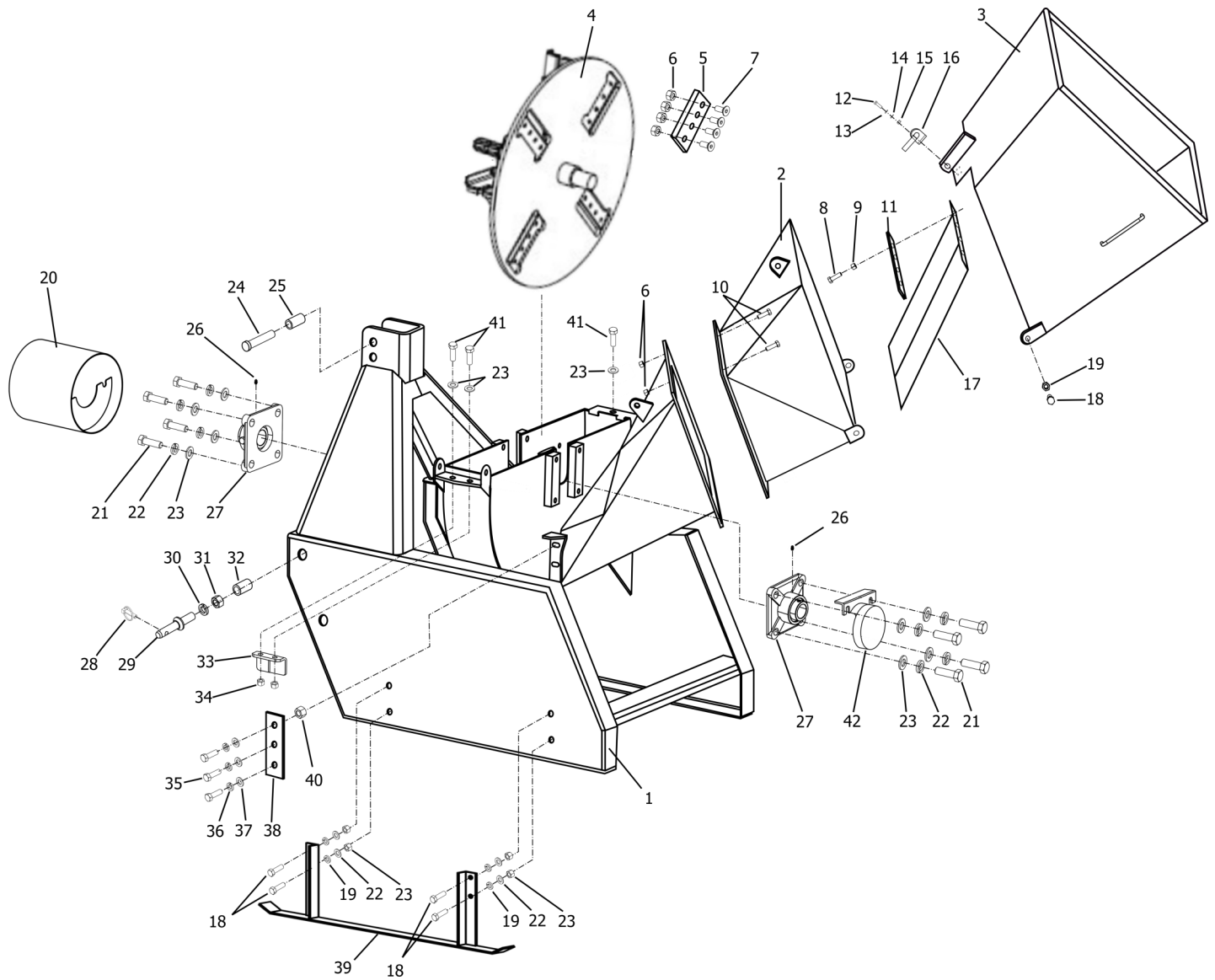

BWC-040EC Frame

Item	Part #	Description	Qty.
1	BX52G-05-01	Chipper frame	1
2		Chute	1
3	BX52G-01	Chute - folding	1
4	BX52-07-01	Disc	1
5	BX52G-07-02	Blade	4
6	LNLM1015	Nut locking M10-1.50	21
7	SSM101530	Socket screw countersunk M10-1.50x30	16
8	BM061020	Bolt HH M06-1.00x20	4
9	LNLM0610	Nut locking M06-1.00	4
10	BM101525	Bolt HH M10-1.50x25	5
11	BX52G-04-03	Support - plastic curtain	1
12	BM040714	Bolt HH M04-.07x14	4
13	LW04	Washer lock M04	4
14	FW04	Washer flat M04	4
15	NM0407	Nut M04-.07	4
16	S/PIN101630	Shoulder pin M10-1.6x30	1
17	BX52G-04-04	Plastic curtain	1
18	BM142040	Bolt HH M14-2.00x40	2
19	LNLM1420	Nut self-locking M14-2.00	2
20	BX52G-08	PTO cover	1
21	BM142045	Bolt HH M14-2.00x45	8
22	LW14	Washer lock M14	8
23	FW14	Washer flat M14	8
24	BX4-0801	Top link pin	1
25	BX52G-01-12	Cat 2 upper bushing M19x25x72	1
26	GN061S	Grease nipple M06-1.00 straight	2
27	BUFC208	Bearing - UFC208	2
28	SB100756	Lynch pin	3
29	BX4-0701	Lower hitch pin	2
30	LW22	Washer lock M22	2
31	NM2225	Nut HH M22-2.50	2
32	BX52G-01-13	Cat 2 lower bushing M22x28/45	2
33	BX52G-05-02-01	Branch breaker	1
34	LNLM12175	Nut locking M12-1.75	3
35	BM0812530	Bolt HH M08-1.25x30	3
36	LW08	Washer lock M08	3
37	FW08	Washer flat M08	3
38	BX52G-05-02-01.11	Anvil	1
39	BX52G-05-01-15	Stand	2
40	NM08125	Nut HH M08-1.25	3
41	BM1217530	Bolt HH M12-1.75x30	3
42	BX40EC30	Bearing cover	1

PTO Assembly

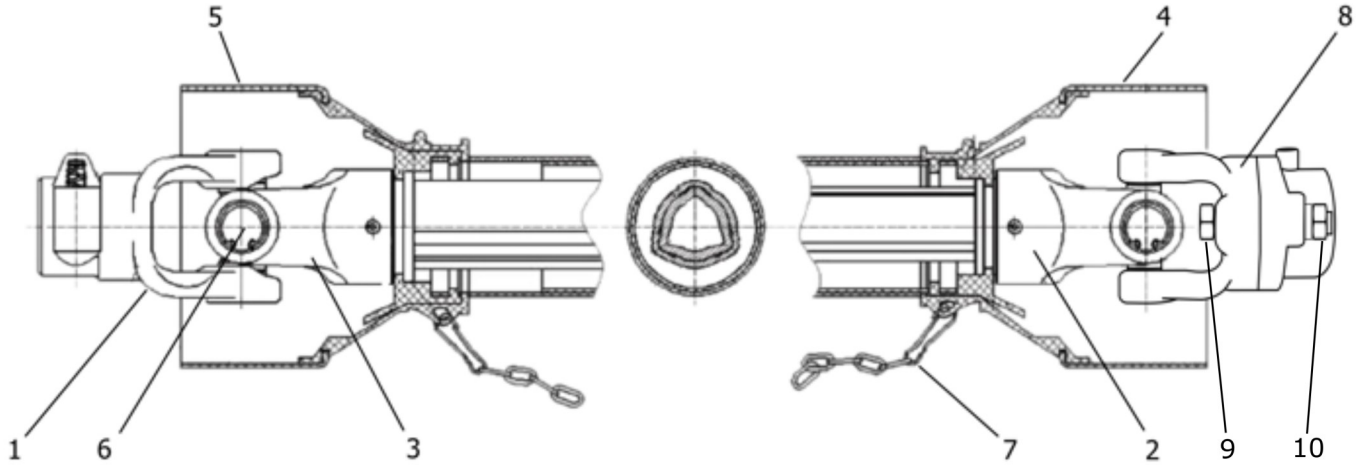

Item	Part #	Description	Qty.
1	DP1075-40	PTO yoke series 40	1
2	DP1078-40	Male yoke and tube (Implement end) Series 40	1
3	DP1079-40	Female yoke and tube (Tractor end) Series 40	1
4	DP1074M-40	Complete male end PTO shielding (implement end) Series 20-40	1
5	DP1074F-40	Complete female end PTO shielding (tractor end) Series 20-40	1
6	DP1076-40	Cross and bearings Series 40	2
7	5SB3007	Safety chain	2
8		Yoke - shear bolt	1
9		Shear bolt	1
10		Nut	1
-	147200	Complete PTO	1

Page left blank intentionally

Decals

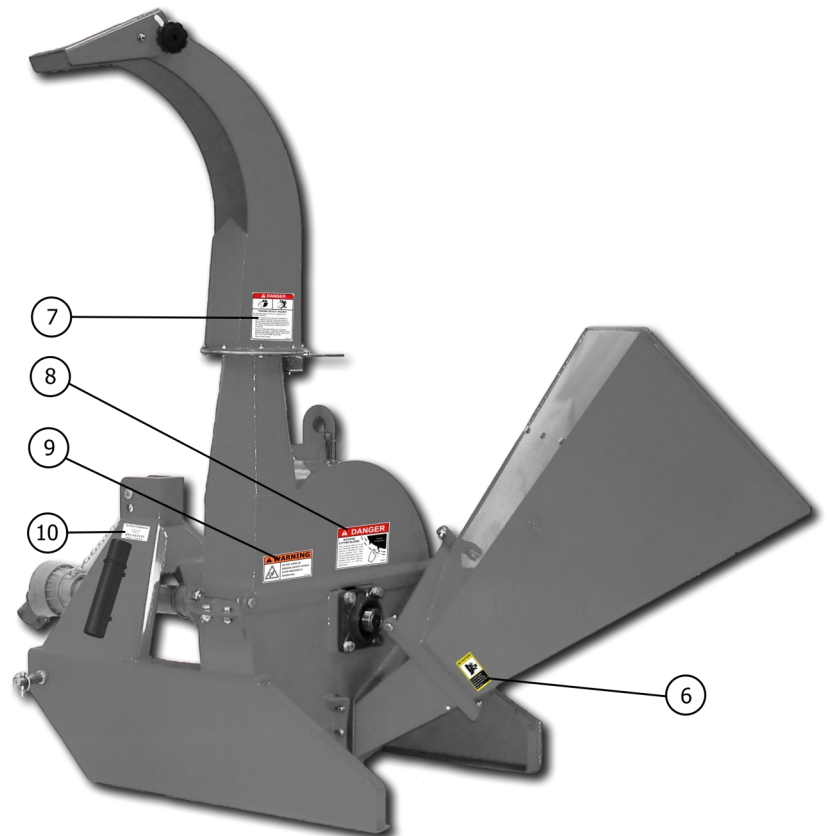
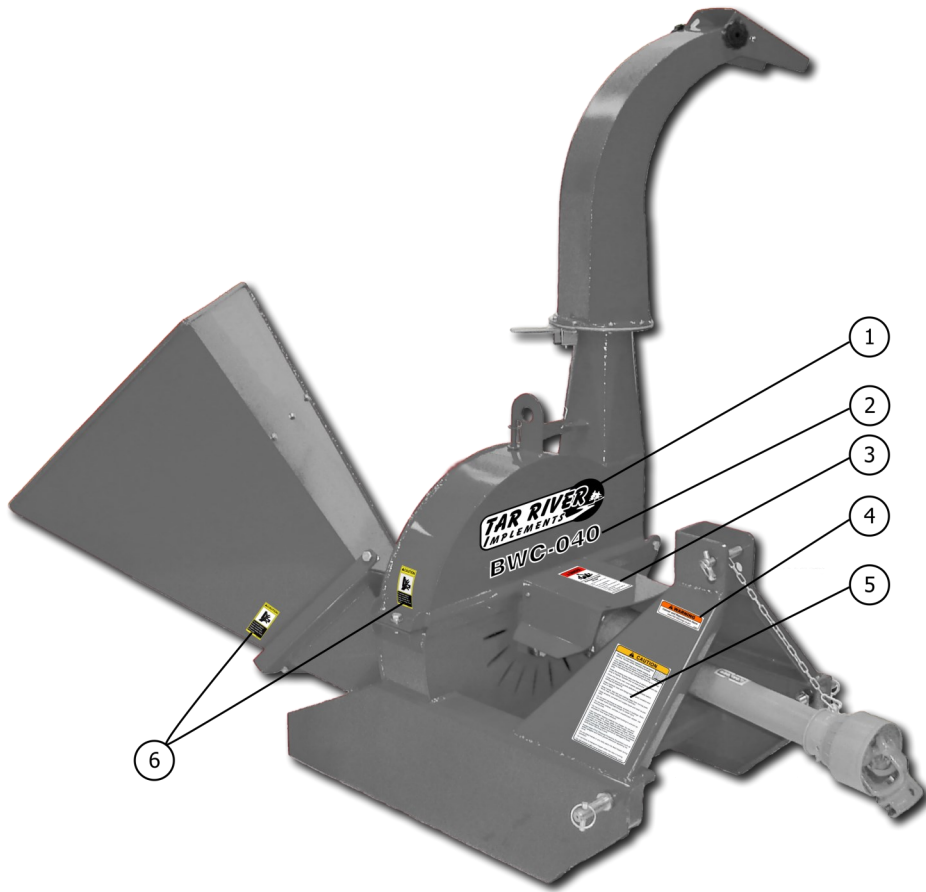

Decals

Item	Part #	Description	Qty.
1	D1015	Decal Logo "Tar River" small	1
2	-	Decal Model # "BWC-040"	1
	-	Decal Model # "BWC-040EC"	1
	-	Decal Model # "BWC-060"	1
3	RT1007	Decal Danger Rotating Driveline	1
4	D960	Decal Warning, "Cancer"	1
5	Z940006	Decal Caution "Read Manual"	1
6	9270112	Decal Caution "Avoid Crushing"	3
7	Z94008	Decal Danger "Thrown Object Hazard"	1
8	Z94007	Decal Danger "Rotating Blades"	1
9	RT1004	Decal Warning "Safety Shield"	1
10	-	Decal Serial Tag	1

Decals



RT1007 Danger Rotating Driveline
Qty. 1



Z94007 Danger Rotating Blades
Qty. 1



Z94008 Danger Object Hazard
Qty. 1



D960 Warning Cancer Qty. 1



9270112 Caution Avoid Crushing
Qty. 3



RT1004 Warning Safety Shield
Qty. 1

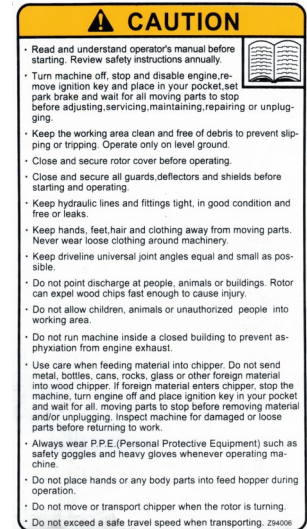

Z94006 Caution Read Manual
Qty. 1



Serial Tag - Qty. 1

BWC-040
BWC-040EC
BWC-060

Model # - Qty. 1



D1015 Tar River Small
Qty. 1

Warranty

LIMITED WARRANTY

Tar River Equipment warrants to the original purchaser of any new piece of machinery from Tar River Equipment, purchased from an authorized Tar River Equipment dealer, that the equipment be free from defects in material and workmanship for a period of one (1) year for non-commercial, state, and municipalities' use, ninety (90) days for commercial use from date of retail sale. Warranty for rental purposes is thirty (30) days. The obligation of Tar River Equipment to the purchaser under this warranty is limited to the repair or replacement of defective parts.

Replacement or repair parts installed in the equipment covered by this limited warranty are warranted for ninety (90) days from the date of purchase of such part or to the expiration of the applicable new equipment warranty period, whichever occurs later. Warranted parts shall be provided at no cost to the user at an authorized Tar River Equipment dealer during regular working hours. Tar River Equipment reserves the right to inspect any equipment or parts, which are claimed to have been defective in material or workmanship.

This limited warranty does not apply to and excludes wear items such as shear pins, tires, tubes knives, blades or other wear items. Oil or grease is not covered by this warranty.

All obligations of Tar River Equipment under this limited warranty shall be terminated if:

Proper service is not performed on the machine.

The machine is modified or altered in any way.

The machine is being used or has been used for purposes other than those for which the machine was intended.

DISCLAIMER OF IMPLIED WARRANTIES & CONSEQUENTIAL DAMAGES

Tar River Equipment obligation under this limited warranty, to the extent allowed by law, is in lieu of all warranties, implied or expressed, including implied warranties of merchantability and fitness for a particular purpose and any liability for incidental and consequential damages with respect to the sale or use of the items warranted. Such incidental and consequential damages shall include but not be limited to: transportation charges other than normal freight charges; cost of installation other than cost approved by Tar River Equipment; duty; taxes; charges for normal service or adjustment; loss of crops or any other loss of income; rental of substitute equipment, expenses due to loss, damage, detention or delay in the delivery.

REGISTRATION

The online Warranty Registration must be completed in order to qualify for coverage on this Limited Warranty. Visit br-equipment.com, click on "Warranty Registration" and completely fill out the form to register the new piece of equipment.

