



FLM Flail Mower

180 / 220H



Do not operate if bystanders or animals are within 100 feet of the mower

TABLE OF CONTENTS

Index

1. DEVICE IDENTIFICATION DATA	4
2. INTRODUCTORY REMARKS	4
2.1. Read the manual carefully	4
2.2. Machine purpose	4
2.3. Important provisions concerning the purchase procedure	4
2.4. Warranty	5
3. GENERAL PRECAUTIONS AND WORK SAFETY	5
3.1. General precautions.....	5
3.2. Transportation.....	5
3.3. Working elements of the machine	6
3.4. Machine attached to the three-point hitch.....	6
3.5. Machine disconnected from the tractor.....	6
3.6. Using the jointed telescopic shaft.....	6
3.7. Handling	6
3.8. Equipment and spare parts	7
3.9. Technical specification	8
3.10. Construction and mode of operation	8
4. OPERATION	11
4.1. Attaching the flail mower to a tractor	11
4.2. Starting work.....	12
5. RECOMMENDED HANDLING	12
5.1. Lubrication	12
5.2. Belt tightness.	13
6. SERVICING, STORAGE, DISPOSAL.....	15
6.1. Storage	15
6.2. Disassembly and disposal.....	15

1. DEVICE IDENTIFICATION DATA

Serial number plate is located on the body of the mower. It is important to keep this number available when ordering parts or optional equipment for the mower.

2. INTRODUCTORY REMARKS



If this symbol is visible next to any point of this manual, read the paragraph carefully, follow the instructions provided therein, and inform other operators of the machine of the said type about the possible danger!

2.1. Read the manual carefully

This manual is an integral part of the machine. Before proceeding to the execution of any works involving the utilization of the flail mower, familiarize yourself with the content of this document.

The manual incorporates info concerning proper usage, operation, and maintenance of the device in question, as well as presents the operational characteristics, requirements allowing for safe and professional usage of the flail mower and ensures the performance and longevity maximization. Moreover, it also comprises of guidelines on replacement of spare parts. Careful lecture of this publication will make it possible for the operator to avoid accidents, keep the warranty valid, as well as to maintain the flail mower in an impeccable condition, making it ready to use always.

2.2. Machine purpose

The machine has been designed for typical agricultural use that is – for mowing and fragmenting relatively small flora (shrubs, stalks of plants, etc.).

Device is fully compatible with class II tractor.

Using the flail mower for any other purpose shall be understood as improper utilization, discharging the producer from the liability for all the damages caused by such exploitation.

- Flail mower can be taken advantage of only by trained individuals who have familiarized themselves with the user's manual and have necessary authorization to drive a tractor.
- Device in question should be professionally used, operated, and maintained (exploitation of the machine by unauthorized personnel such as children or teenagers may result in posing threat to their health and life. It may also lead to damaging the device).
- Always follow safety precautions provided in this publication, general safety measures, work safety principles, and traffic regulations.
- Follow safety precautions and work safety principles while performing machine maintenance or operation related undertakings.
- Unauthorized modifications of the device shall result in discharging the producer from the liability for all the damages caused by such adjustments.

2.3. Important provisions concerning the purchase procedure

This publication shall be presented to the purchaser together with the device. The Selling Party shall fill in the "Agricultural machine and user's manual collection protocol". Before the acceptance of the device, check its completeness basing on the Shipping Specification and examine whether the Selling Party had properly filled in the warranty card, complaint coupons, and the title page of this manual.

2.4. Warranty

Warranty terms are provided in the warranty form. The careful lecture of this document is one of the obligations of the operator. The failure to comply with the regulations on proper exploitation of the device will lead to the decrease in its performance, increase in the malfunction risk, and the fact of the warranty being deemed invalid. The warranty will be specifically cancelled in the following cases:

1. Identifying mechanical damages caused by disregarding the indications of the manual on proper operation, especially – by mowing while on the reverse gear.
2. Fixing the device by servicing companies other than the Selling Party, Producer, or a company suggested by the said parties.
3. Using unoriginal parts while repairing the flail mower;
4. Modifying the construction of the device.

3. GENERAL PRECAUTIONS AND WORK SAFETY

Many accidents occurring while using, operating, or transporting the device results from the failure of the operator to comply with basic safety precautions. It is important for the user to make use of the recommendations provided below and follow them as strictly as possible:

3.1. General precautions

1. **FOLLOW** the recommendations of this publication, as well as general work safety principles!
2. **OBSERVE** safety indications and symbols located on the device. They have been placed there for user's safety!
3. **IT IS FORBIDDEN** to use the machine without the required covers attached. If they have been damaged, replace them using original components.
4. **FLAIL MOWER SHOULD BE USED** after reaching the nominal PTO (power take-off) rotational speed of the tractor. For "URSUS" C-360, C-385m tractors, as well as the ones with a bigger engine, the said speed is equal to 540 RPM. Moreover, the rotational velocity of 600 RPM should not be exceeded.
5. **UNDER NO CIRCUMSTANCES** should the machine be inspected or repaired while some parts are still moving. It is highly recommended to wait for them to stop before attempting to inspect the device. Avoid wearing clothes that may be easily torn apart by the moving components of the flail mower.
6. **UNDER NO CIRCUMSTANCES** should the operator leave the working machine unattended.
7. Make sure that there are no unauthorized individuals or animals in the vicinity of the mower before its use, as well as while working. **It is strictly forbidden to use the flail mower while non-operators are within 100 feet of the mower!**
8. **IT IS FORBIDDEN** to climb on the machine.
9. **FIELDS OR MEADOWS** should be properly prepared for the use of the flail mower – all the larger rocks and hard objects should be removed.
10. **FLAIL MOWER** must not be used while backing up.
11. **TRACTOR** used should be equipped with a driver's cabin.
12. **IT IS STRICTLY FORBIDDEN** to stand between the tractor and the machine.
13. **POSITIONING** of the hydraulic lift lever should only be done by the operator while sitting in the driver's cabin of the tractor.
14. **CHANGING** the position of the lever from the outside of the tractor is not allowed.
15. **DO NOT LIFT** the machine by means of the hydraulic lift of the tractor when its engine is on and the working shaft is still rotating.
16. **USING** the flail mower on slopes up to 30° is safe.

3.2. Transportation

- Before setting the flail mower in the transporting position, make sure that the PTO of the tractor is on and all moveable parts are stopped.

- **BE EXCEPTIONALLY CAREFUL** while transporting the machine along public roads; follow traffic regulations. Moreover, for the transportation period, attach a signaling device and a triangular warning plate to the device.
- **ADJUST** the driving speed to the current road conditions. Do not drive too fast!
- **NOTE** – while turning, the machine may lean backwards or to the sides.

3.3. Working parts of the machine

- Before using the flail mower, check if the blades are properly attached.
- Blades that are worn out or damaged should be immediately replaced with new and original spare parts.



3.4. Machine attached to the three-point hitch



Before attaching the machine to or removing it from the three-point hitch of the tractor, set the hydraulic lift lever of the tractor in the position in which the involuntary lifting or lowering the device is impossible.

Suspension categories of the tractor and the machine must be in line. While the flail mower is in the transporting position, check the stability of the tractor on the sides of the machine connector. While transporting the device in the lifted position, the hydraulic lift lever must be always secured against uncontrolled position change.

3.5. Machine disconnected from the tractor

Set the machine on a stable surface before removing from the tractor.

3.6. Using the PTO driveline

- It may be necessary to cut the PTO driveline to the length to fit your tractor. **If the PTO driveline is too long, it may damage the machine or tractor.** Contact your dealer for the correct way to shorten the PTO driveline.
- Use shafts recommended in this manual only.
- All the protective covers of the jointed telescopic shaft must be in a proper condition. If they are damaged, there is the need to replace them immediately.
- Always attach and remove the shaft when the PTO and engine are turned off and the key is turned off!
- Both halves of the jointed telescopic shaft should commensurate with one another in both transporting and working positions!
- Shaft cover should be protected by means of a chain to prevent its rotating together with the shaft!
- Before turning the PTO on, check if the direction of rotation and the rotational speed of the PTO are equal to the ones of the jointed telescopic shaft.
- Ensure that there are no unauthorized individuals in proximity to the machine before turning the shaft on.
- After turning the said component off, wait for the inertial rotations to stop and only after that allow other individuals to approach the flail mower.
- When the jointed telescopic shaft is turned off, attach protective covers to it and locate it in the designated storage area.
- In the case of the occurrence of any damages, they must be fixed before the next use of the shaft.

3.7. Handling

All the adjustment, maintenance, or fixing-oriented works must be attempted if the engine is off and the keys are removed from the ignition!

Consider all the possible dangers that may occur while switching the position of the machine from working to transporting one.

While attempting to inspect or repair the device, always wear protective clothing and gloves – especially if the blades are to be replaced!

It is forbidden to use the flail mower on the corners of the streets, roads, public areas (parks, schools, etc.) or on rocky surfaces; avoid the danger that may be caused by stones and other objects being ejected from under the flail mower in an uncontrolled manner.

All stickers attached to the machine must be fully legible. In the case any damage, it is the responsibility of the owner /user/ to replace them.

Only „B” safety class jointed telescopic shafts with the following parameters should be used: transferred torque 610 Nm, length (minimal, between the axis of the joints) 710 mm.

3.8. Equipment and spare parts

Following equipment is provided together with the flail mower:

1. User's manual with spare parts catalog 1 pc.

3.9. Technical specification

	FLM-180	FLM-220H
Type	3 Point	
Shredding area width	68"	84"
Required power	Min. 30 HP	Min. 50 HP
Number of Hammers	26	34
Tractor's PTO	540 RPM	
Cutting Speed	approx. 3 1/4 Acres/Hour	approx. 4 3/4 Acres/Hour
Working speed	5-6 HP	
Transporting speed	12 mph	
Length	40"	
Width	81"	97"
Height	38"	
Weight	922 lbs	1060 lbs
Side Shift reallocation	15 3/4"	

3.10. Construction and mode of operation

Construction of the flail mower is presented in figure 1.

- Body (1),
- Working shaft (2),
- Driving shaft (3)
- Bevel gear (4)
- Gear cover (5)
- Sliding chute (6)
- Fixed panel (7)
- Moving panel (8)
- Front curtain (9)
- Rear curtain (10)

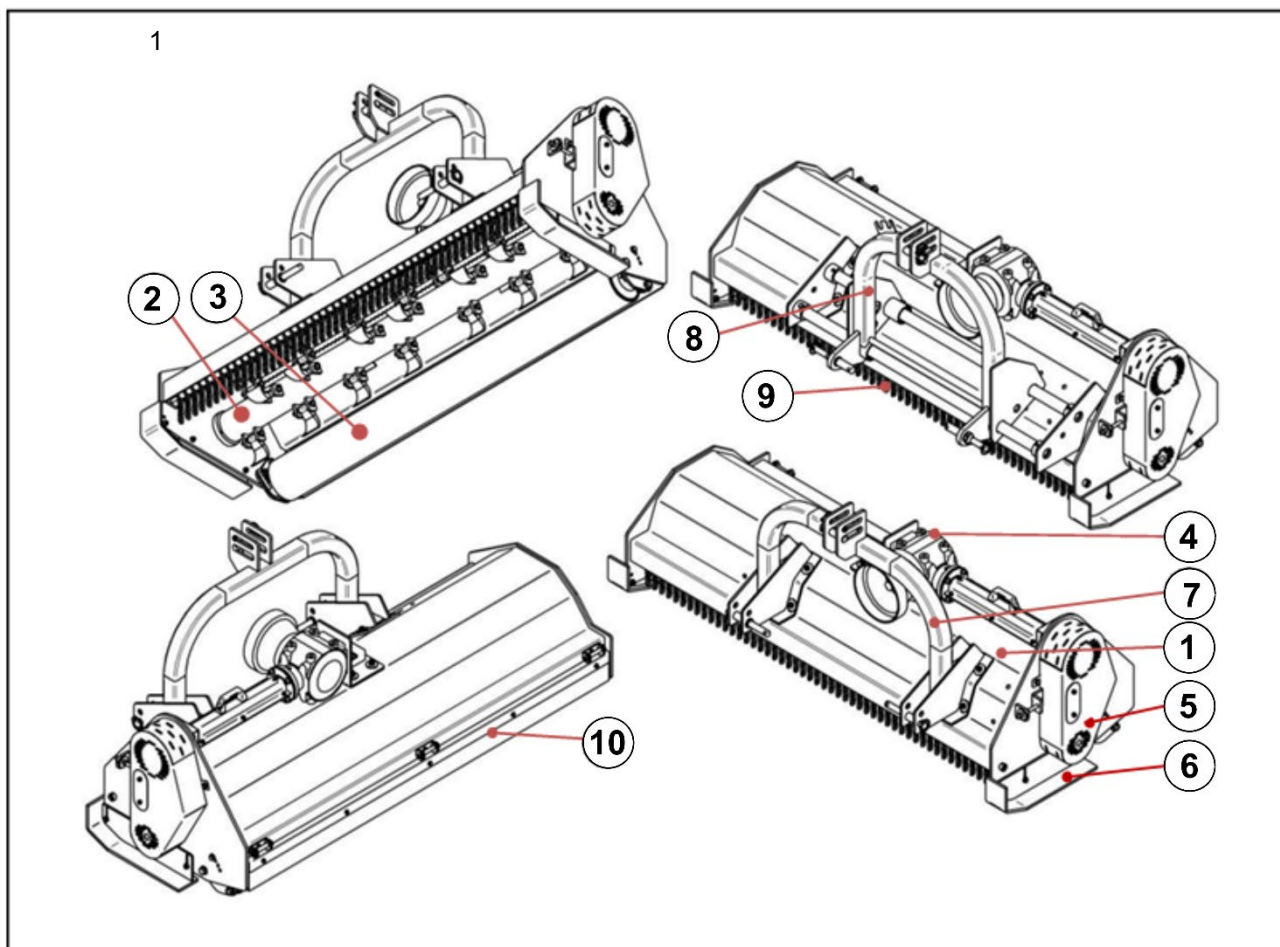

Figure 1 Construction, mode of operation – main parts.

The flail mower is attached to the three-point hitch of the tractor. The working shaft (3) is powered by the PTO of the tractor via the jointed telescopic shaft, bevel gear (4) and belt drive.

Working elements of the machine are blades or beaters situated on the working shaft. The latter is located inside the body. The machine moves on the surface by means of wheels or a driving shaft.

The flail mower is also equipped with chain curtain protecting the operator and non-operators from rocks and hard objects being ejected at the front.

Moreover, the body protects the operator and other individuals from being hit with hard objects such as rocks laying on the field that may be ejected by the working shaft.

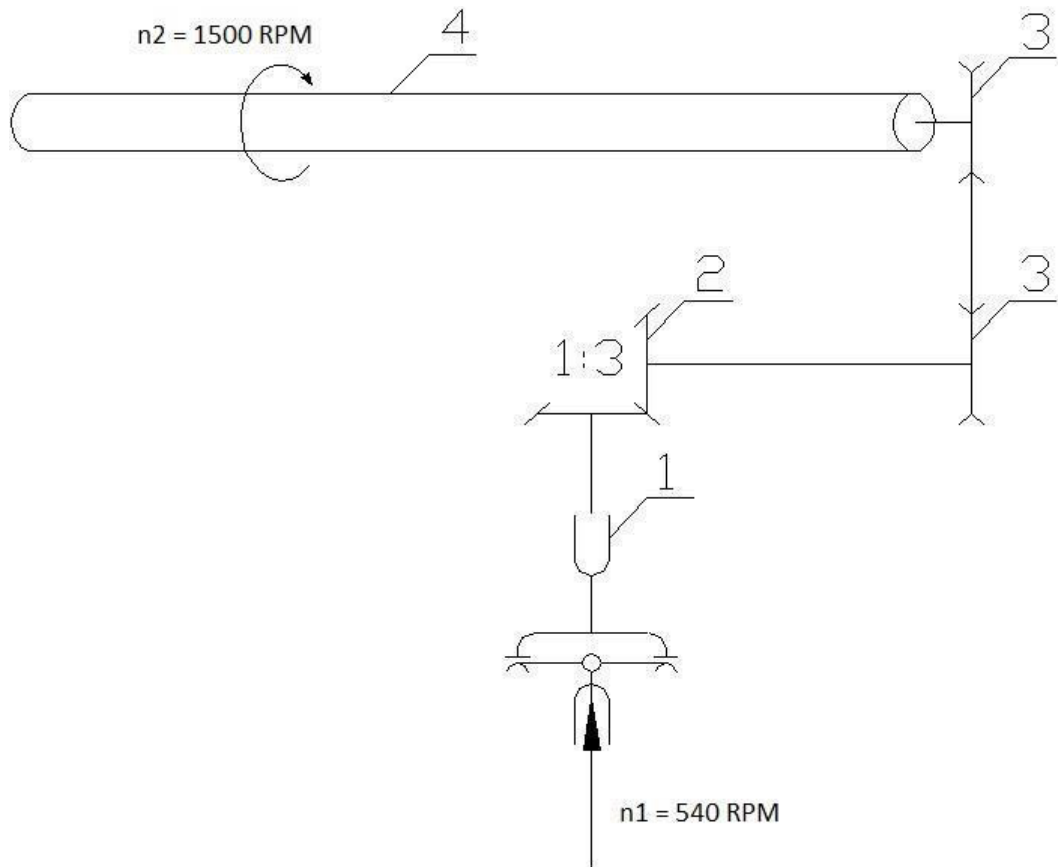

Fig. 2 Flail mower drive: 1 - jointed telescopic shaft, 2 – bevel gear, 3 –belt drive, 4 – shaft.

4. OPERATION

4.1. Attaching the flail mower to a tractor

The machine compatible with II class agricultural tractors.

To keep the longitudinal balance and maneuverability of the machine, the front axes of the used tractor shall be loaded with additional weights (being parts of tractor's equipment).

The device is attached to the vehicle by means of three-point hitch (TPH):

- Locate pins (1) of the flail mower's suspension in the holes of two lower ball joints of the tractor and secure them with cotters,
- Connect the holes in the slotted lever (2) with the upper pin of the tractor and secure it with a cotter.

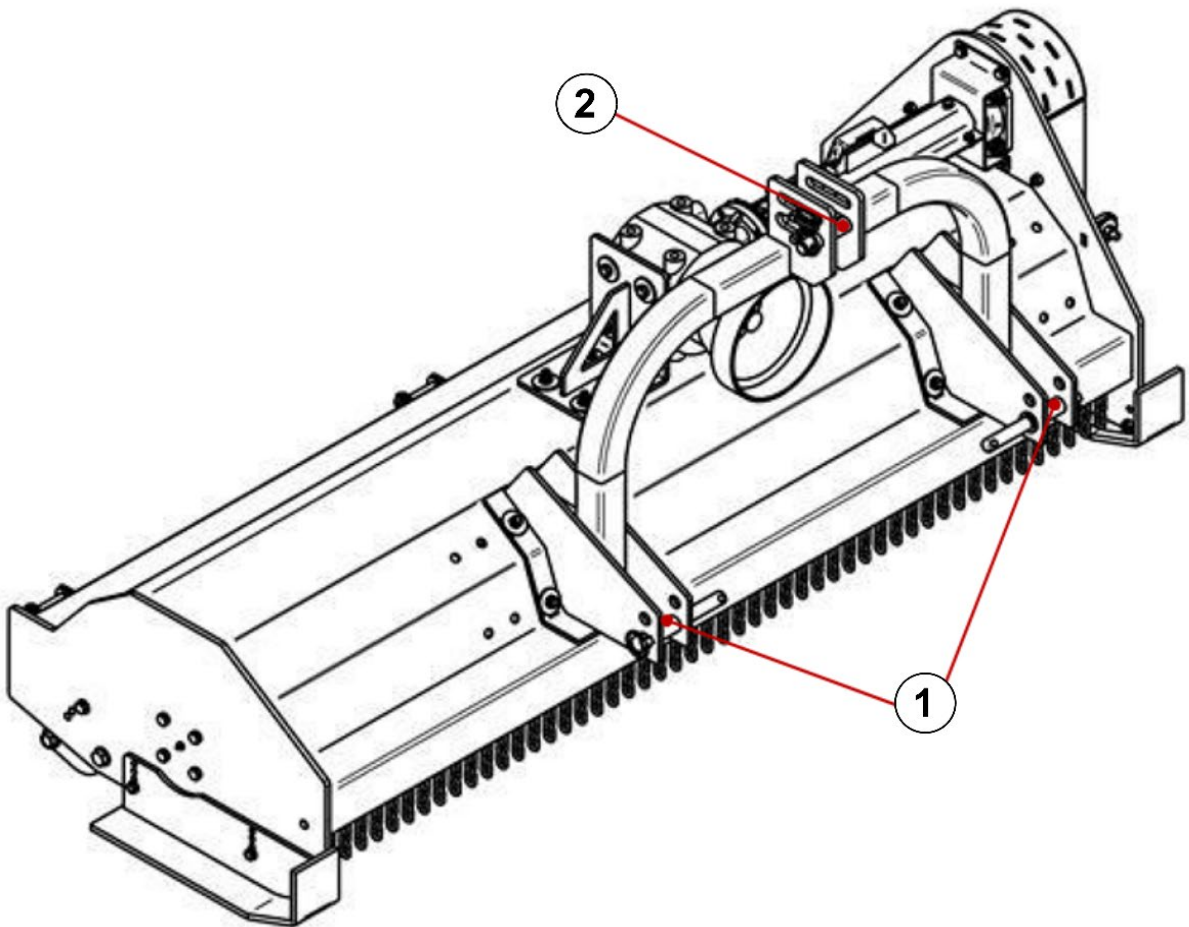

Figure 3 Flail mower attachment



Under no circumstances should the operator stand in the front of the device while connecting it. While changing machine's position from working to transporting and the other way around, the operator must not stand in the close proximity to the moving elements.

- Install the jointed telescopic shaft - connect the ends of the shaft (forks) to the PTO of the tractor and shaft of the device. Secure the forks against disconnecting by means of latches. While installing the jointed telescopic shaft, the external pipe being a part of the cover must be located on tractor's side.
- **Make sure the PTO driveline is cut to the proper length before lifting the machine.**

4.2. Starting work

Switch on the drive of the machine. Only after reaching the recommended rotational speed (540 RPM on the PTO), can the device be used for shredding. Driving speed should be adjusted to the terrain and the type of material to be processed. The flail mower should not be used to mow rocky fields.

If the machine encounters an obstacle, the tractor must be stopped and the drive – turned off.

5. RECOMMENDED HANDLING

At least once a year, check the oil level in the gear. The all-purpose GL 4 80W90 gear oil may be used by the operator.

- Check the tightness of drive belts.
- Check the overall condition of the device.

5.1. Lubrication

For the machine to work in a satisfactory manner, it must be carefully and accurately lubricated in accordance with the scheme below.

T-313J gear is filled with 1.5 liter of 80W90 gear oil (change oil every year).

All the points indicated in Figure 3 are equipped with ball nipples that should be filled with the GP grease. The telescopic part of the driveline should be greased no later than after 8 hours of work – it should be fully extended, and all the contamination should be removed before starting the oiling procedure.

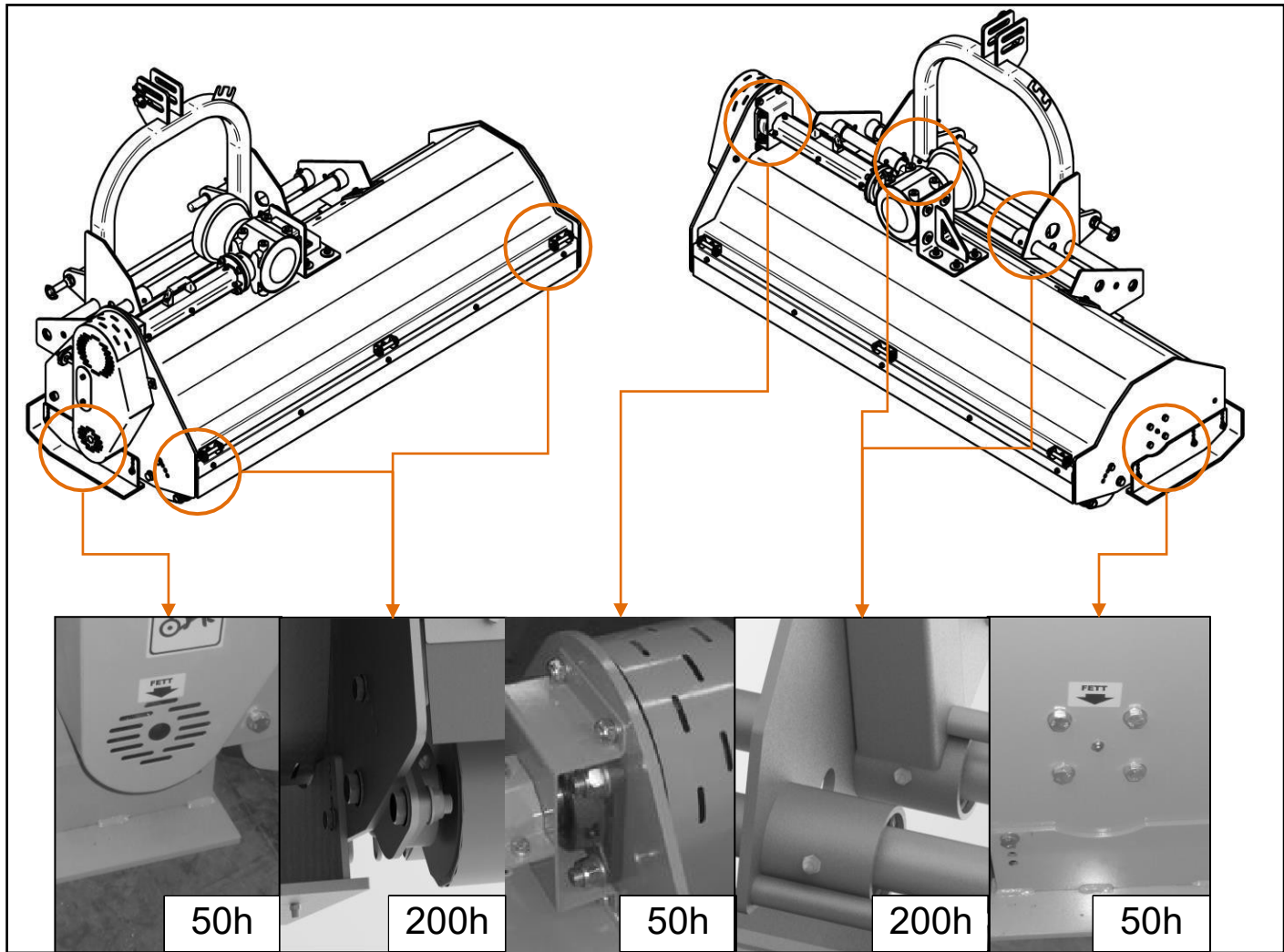

Figure 4 Lubrication scheme

5.2. Belt tightness

Before increasing the tightness of the belts, the inspection window should be open. To do so, unscrew two M8 bolts (1). Afterwards, loosen the M14 bolt (2) located in the inspection hole. The next step is to loosen the M12 nut (4) by turning it clockwise. Properly tightened belts should move down 15-20 mm while trying to clench them together (if the tightness check is needed, the cover (5) should also be removed. It is attached to the body by means of M8x30 bolts with flat washers (6). After regulating the belts, tighten the M14 bolt (2). By means of the M 12 nut (3), tighten up the said bolt and close the inspection hole by means of M8 bolts (1). The tightness of the belt should be checked periodically as it greatly influences the longevity of the components in question.

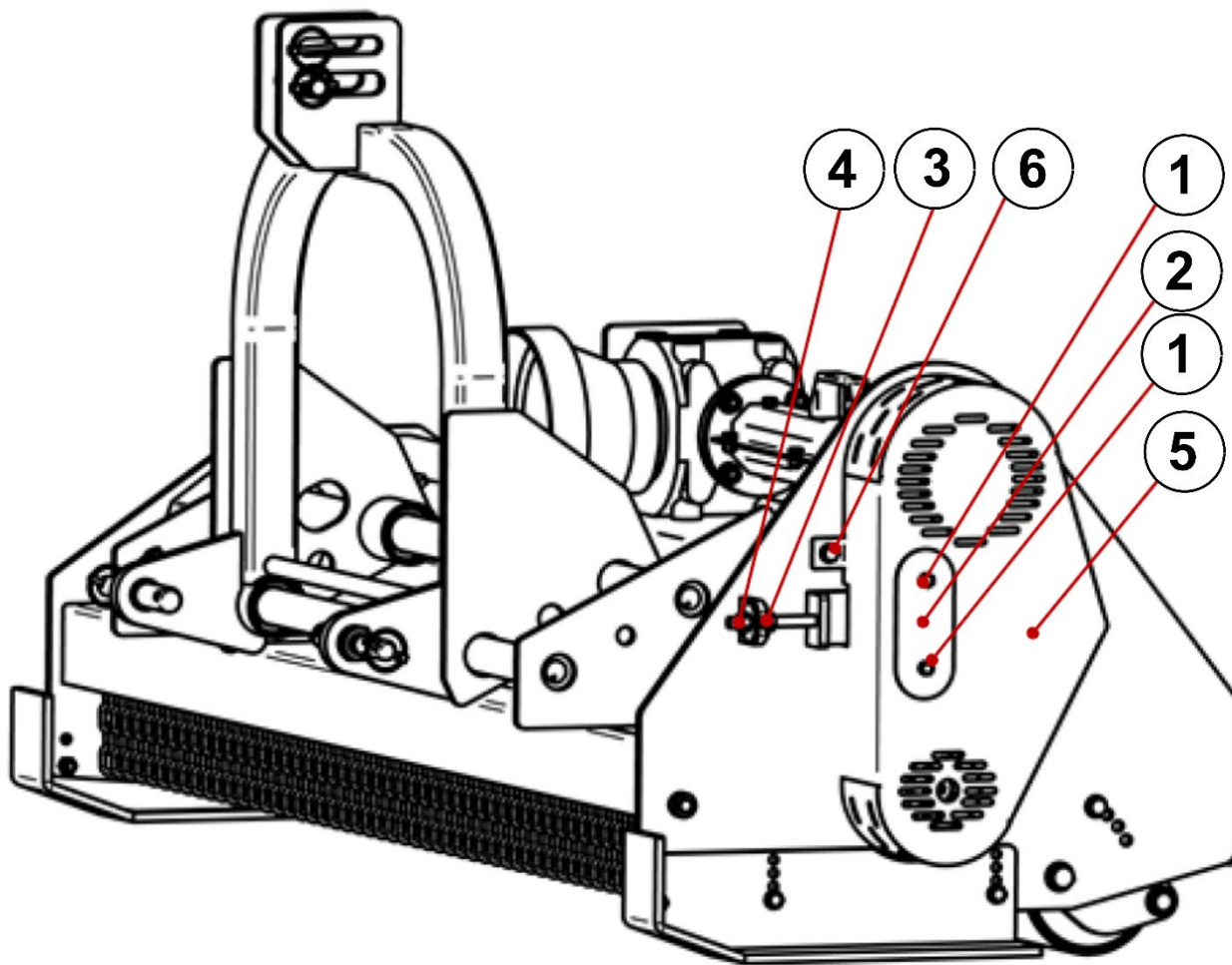

Figure 5

6. SERVICING, STORAGE, DISPOSAL

Every day, after finishing the work, the flail mower must be meticulously cleaned, and its technical condition must be inspected. The operator should especially pay attention to the wear of blades or beaters. Replace damaged or worn-out parts.

Before starting the work, lubricate telescopic parts of the jointed telescopic shaft.

After the finished operation period:

- Remove all the contaminations,
- Check the condition of the machine and replace the worn-out parts using the ones recommended by the producer,
- Lubricate the machine in accordance with the instructions of the lubrication scheme (Fig. 5),

Every 5 years change fan belts and hydraulic hoses by replacing them for new ones.



All repairs and replacements of components of machine's drive should be performed by authorized mechanics equipped with required tools and devices.

6.1. Storage

The flail mower should be kept in a dry place and be additionally secured against the negative effects of unfavorable weather conditions. If the machine is affected by any form of downpour, the lubrication procedure should be repeated more often.

6.2. Disassembly and disposal

The damaged or worn-out machine should be disposed in accordance with environment protection principles. In order to do so:

- disassemble the machine
- dispose of metal elements at a junkyard.

7. PARTS CATALOG

SPARE PARTS ORDERING:

While placing an order, provide the following:

- Ordering party's address,
- Exact shipping address (together with the machine location and collection method),
- Payment terms,
- Serial number and the year of construction of the sweeper (provided on the nameplate), □ Exact name of the spare part,
- Number of ordered parts.

Spare parts shall be ordered in authorized outlets or directly from the producer.

INDEX OF FIGURES

Figure 1 Construction, mode of operation – main parts.....	9
Figure 2 Flail mower drive	9
Figure 3 Flail mower attachment.....	10
Figure 4 Lubrication scheme	141
Figure 5 Belt tightening scheme	12

Figure 6 Working shaft assembly scheme	<u>15</u>
Figure 7a Driving shaft assembly scheme	<u>16</u>
Figure 7b Driving shaft assembly scheme	<u>16</u>
Figure 8a Gear	<u>17</u>
Figure 8b Gear	<u>18</u>
Figure 9 Sliding chute.....	<u>19</u>
Figure 10 Fixed panel attachment scheme	<u>20</u>
Figure 11 Moving panel attachment scheme	<u>21</u>
Figure 12 Front curtain	<u>22</u>
Figure 13 Rear curtain.....	<u>23</u>

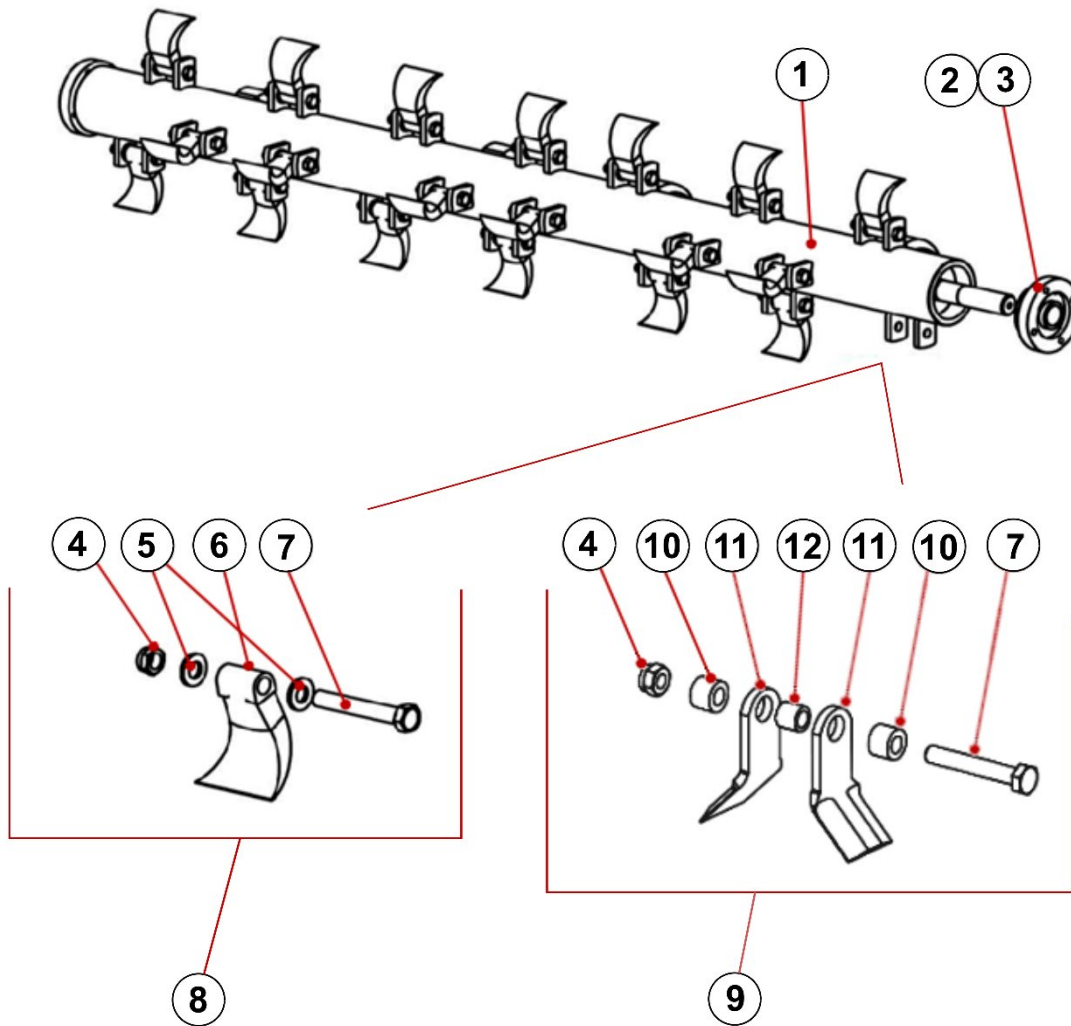

Pos.	Part #	Description	Qty
1	TFF6-01-180	Rotor Shaft – FLM-180	1
1	TFF6-01-220	Rotor Shaft – FLM-220	1
2	TFF6-02	Bearing Support	2
3	BUC207	Bearing UC207	2
4	LN14175	Self-locking Nut- M14 x 1.75	-
5	TFF6-05	Spacer	-
6	TFF10001	Hammer knife - single	*
7	BM142090	Bolt- M14 x 1.75 x 90	-
8	TFM1098	Hammer knife kit, includes (1) hammer knife, hardware & spacers	-
9	TFM1099	Y knife kit, includes (1) Y knife, hardware & spacers	-
10	TFF10004	Spacer, outer	-
11	TFF10002	Y knife - single	*
12	TFF10003	Spacer, inner	-

Figure 6 Rotor shaft assembly scheme

*26 blades for FLM180 and 34 for FLM220

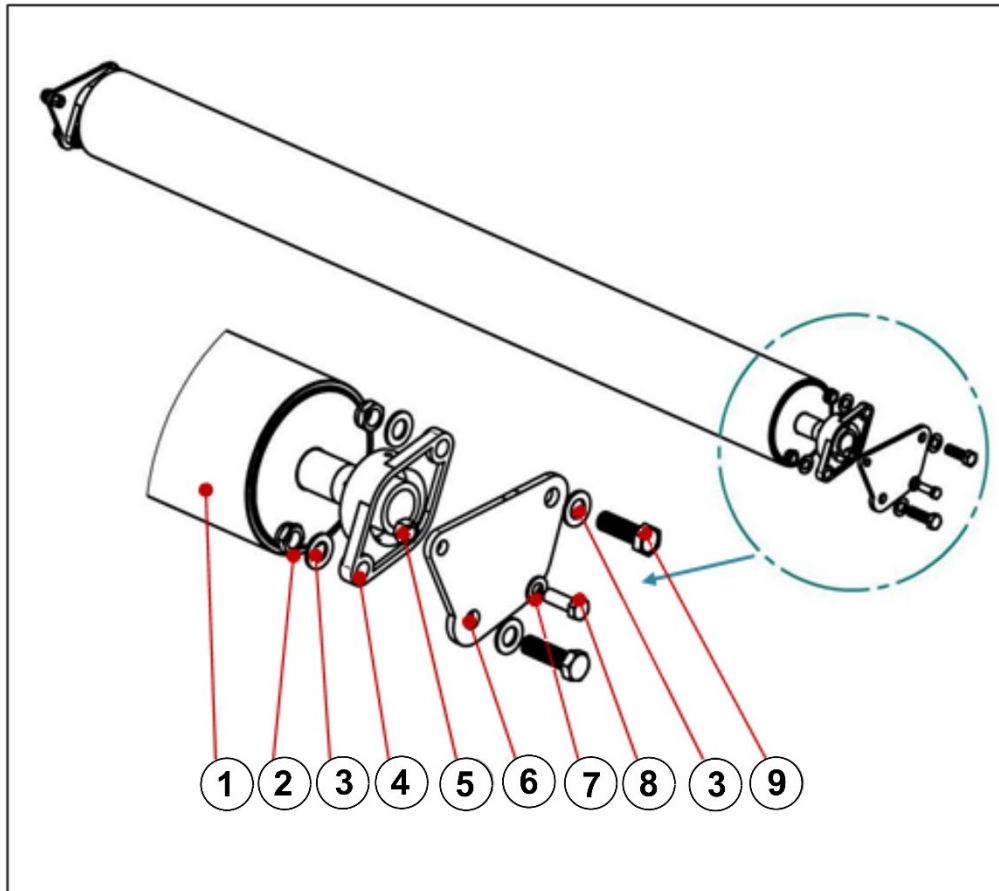

Figure 7 Roller assembly scheme

Pos.	Part #	Description	Qty
1	TFF7-01-180	Roller – FLM-180	1
	TFF7-01-220	Roller – FLM-220	1
2	LNM1620	Self-locking Nut- M16 x 2.0	4
3	FW16	Flat Washer- M16	4
4	BUCFL207	Bearing UCFL207	2
5	LNM12175	Self-locking Nut- M12 x 1.75	2
6	TFF7-06	Roller Support	2
7	FW12	Flat Washer- M12	4
8	BM1212535	Bolt- M12 x 1.75 x 35	2
9	BM161555	Bolt- M16 x 2.0 x 55	4

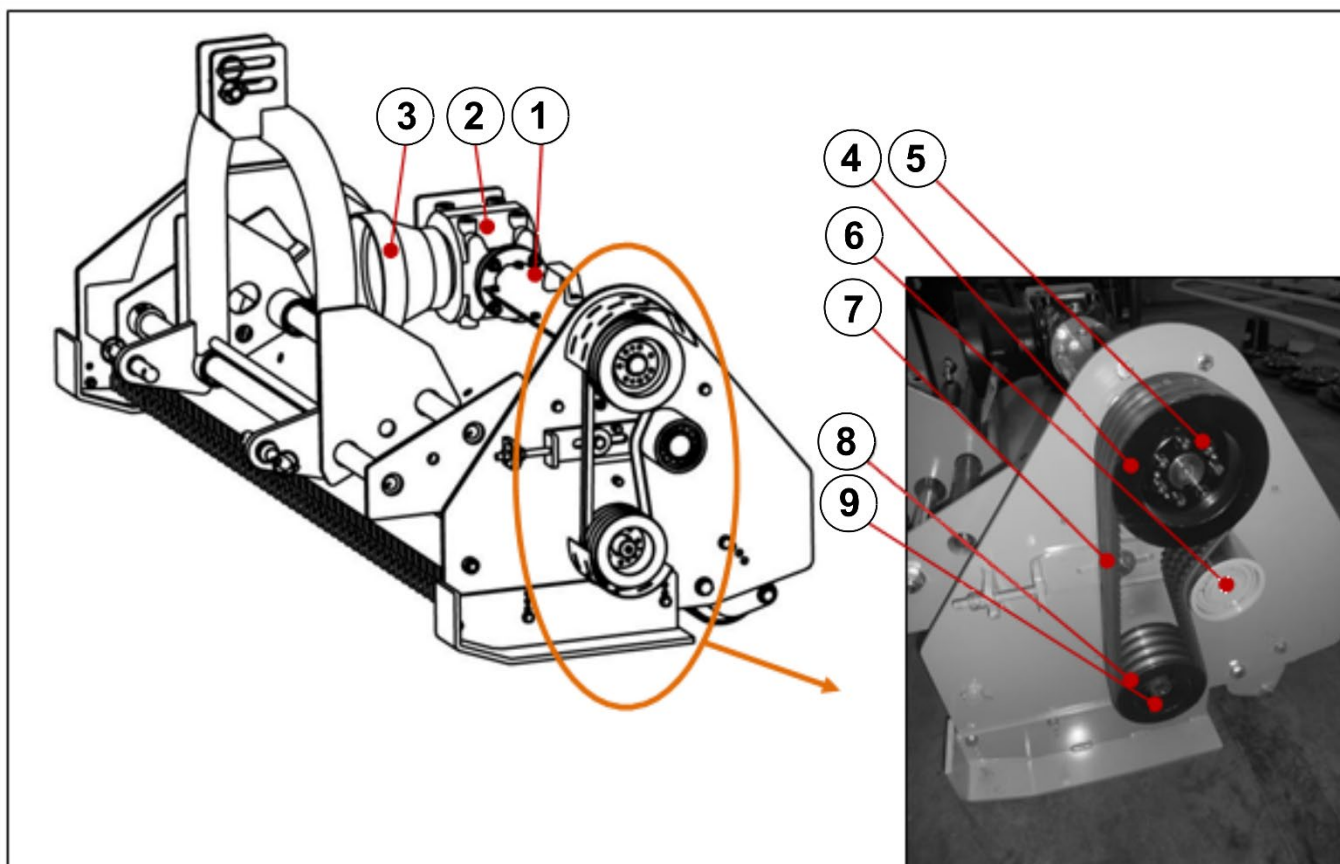

Figure 8A Gear

Pos.	Part #	Description	Qty
1	TFF8A-01	Driving Shaft Cover	1
2	TFF8A-02	Gear	1
3	TFF8A-03	Shield Input Shaft	1
4	TFF8A-04	Pulley - Drive	1
5	TFF8A-05	Clutch	1
6	TFF8A-06	Complete Tensioner: See Table below for Parts Description	1
7	TFF8A-07	Belt – HB1165	4
8	TFF8A-08	Pulley – Driven	1
9	TFF8A-09	Clutch	1

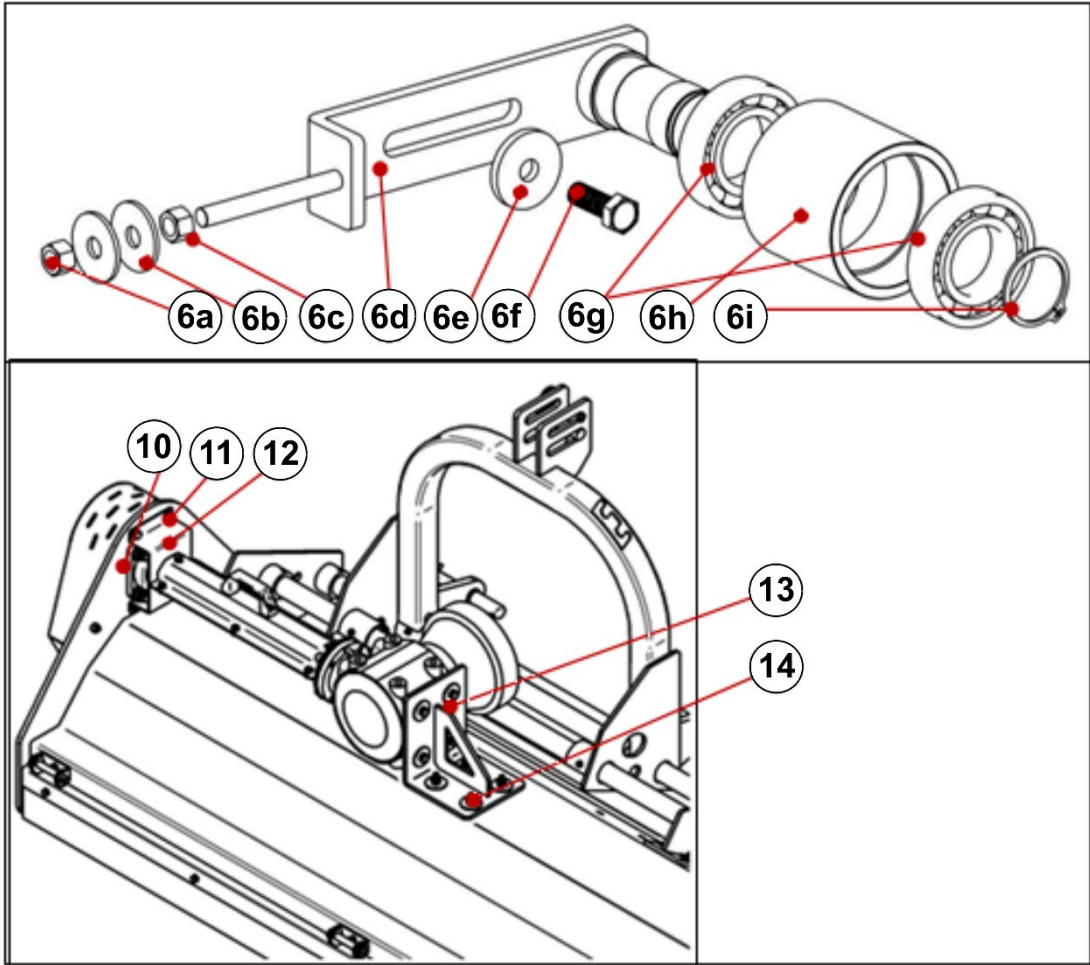

Figure 8b Gear

Pos.	Part #	Description	Qty
6a	LNM12175	Self-Locking Nut- M12 x 1.75	4
6b	FW12	Flat Washer- M12	8
6c	LNM12175	Self-locking Nut- M12 x 1.75	
6d	TFF8B-6D	Tensioner body	
6e	TFF8B-6E	Flat Washer	
6f	BM142040	Bolt- M14 x 2.0 x 40	
6g	B6209	Bearing- 6209	
6h	TFF8B-6H	Tensioner Roll	
6i	SRI-45	Snap Ring- Internal- M45	
10	BUCF208	Bearing UCF208	
10	BM161540	Bolt- M16 2.0 x 40	
10	NM162	Nut- M16 x 2.0	
10	LW16	Lock Washer- M16	
11	BM1015	Bolt- M10 x 1.5	
11	LNM1015	Self-locking Nut- M10 x 1.5	
11	FW10	Flat Washer- M10	
12	TFF8B-12	Console	
13	TFF8B-13	Gearbox Support Bracket	
13	BM121540	Bolt- M12 x 1.75 x 40	1
13	LW12	Lock Washer- M12	1
14	BM121540	Bolt- M12 x 1.5 x 40	4
14	LFW- M12	Large Flat Washer- M12	
14	LNM12175	Self-Locking Nut- M12 x 1.75	

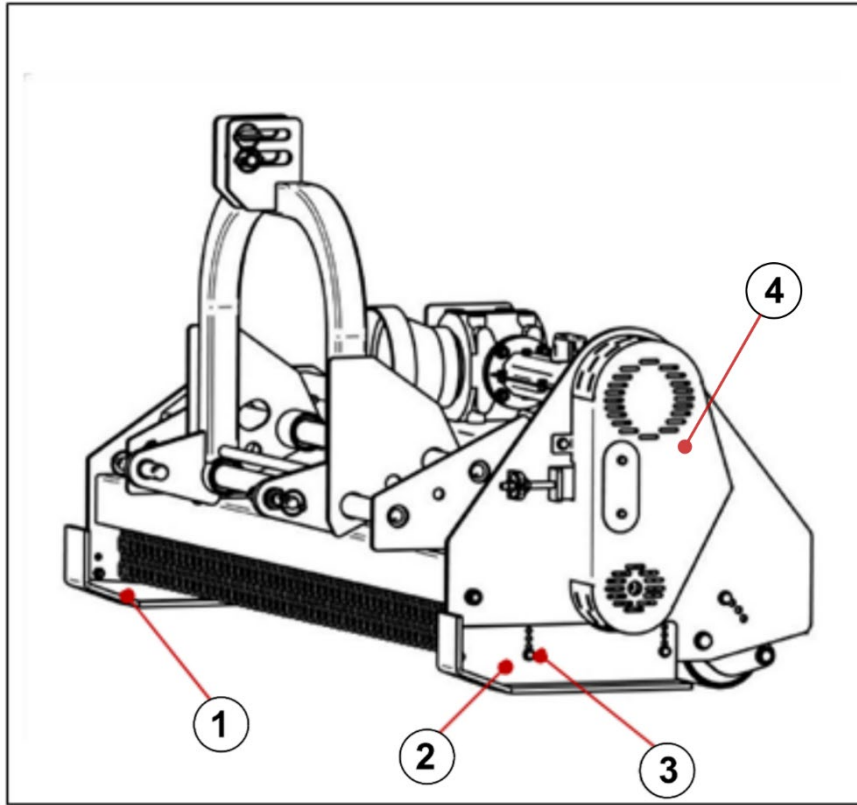

Figure 9 Sliding chutes

Pos.	Part #	Description	Qty
1	TFF9-01	Skid - Right	1
2	TFF9-02	Skid - Left	1
3	BM101535	Bolt- M10 x 1.5 x 35	4
3	FW10	Flat Washer- M10	4
3	LNM1015	Self-Locking Nut- M10 x 1.5	4
4	TFF9-04	Belt Shield	1

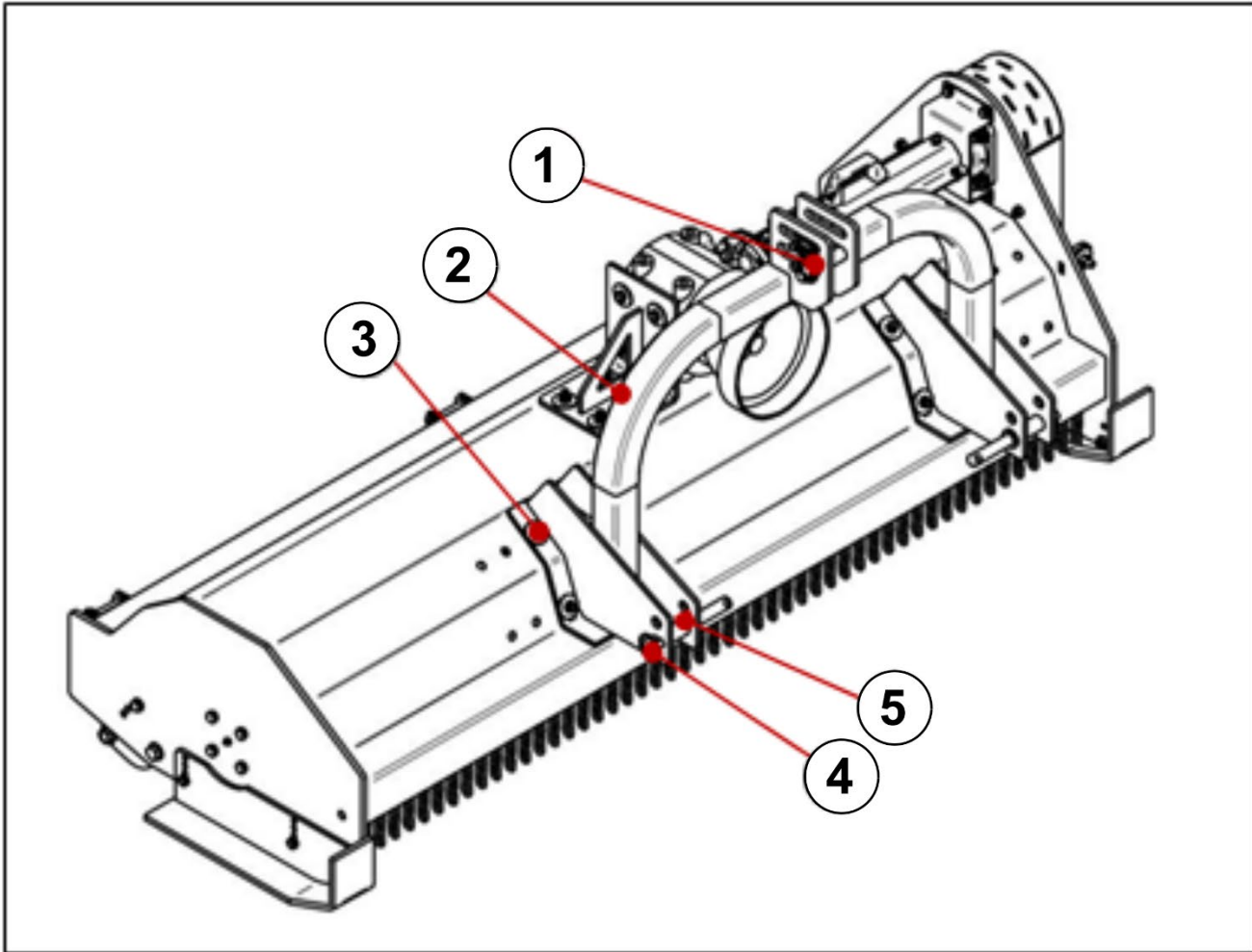

Figure 10 Fixed panel attachment scheme

Pos.	Part #	Description	Qty
1	TFF10-01	Top Hitch Pin	1
2	TFF10-02	A Frame	1
3	BM1217530	Bolt- M12 x 1.75 x 30	8
3	FW12	Flat Washer- M12	16
3	LNM12175	Self-locking Nut- M12 x 1.75	8
4	LYNPN10	Lynch pin- M10	3
5	TFF10-05	Lower Hitch Pin	2

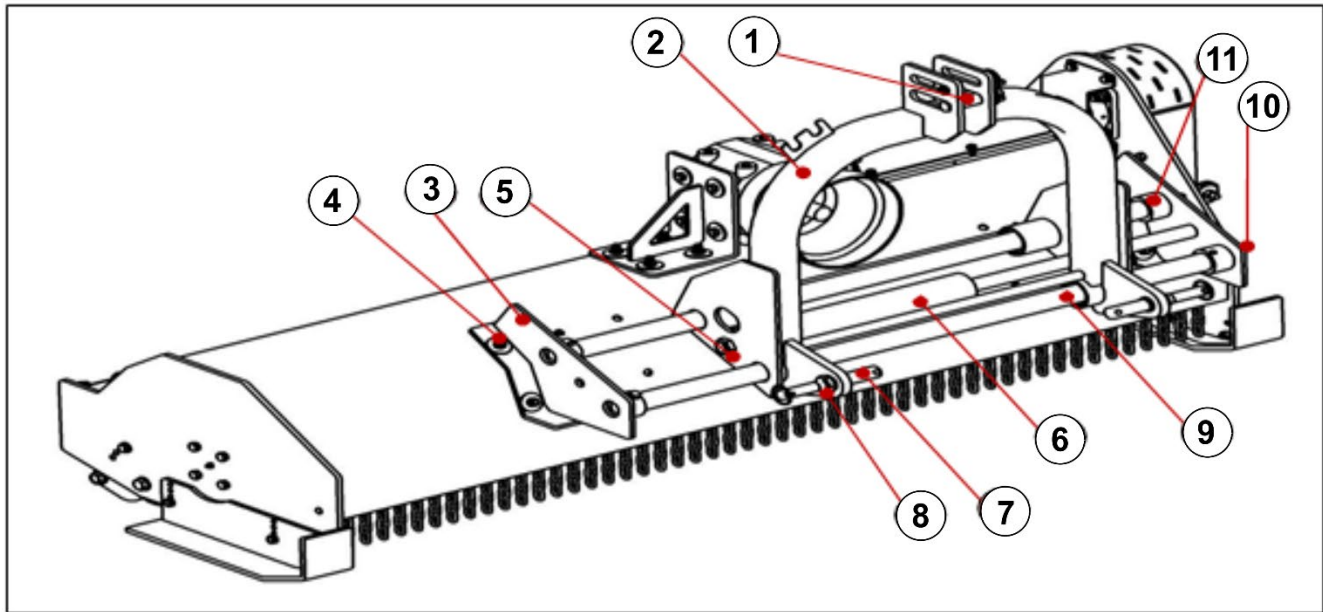

Figure 11 Moving panel attachment scheme

Pos.	Part #	Description	Qty
1	TFF10-01	Top Hitch Pin	3
2	TFF11-02	A Frame - Hydraulic	1
3	TFF11-03	A Frame Mount - Right	1
4	BM1217530	Bolt- M12 x 1.75 x 30	8
4	FW12	Flat Washer- M12	16
4	LNM12175	Self-locking Nut- M12 x 1.75	8
5	LNM2025	Self-locking Nut- M20 x 2.5	2
5	FW20	Flat Washer- M20	2
6	TFF11-06	Cylinder	1
7	TFF10-05	Lower Hitch Pin	2
8	TFF11-08	Hitch Pin Complete	2
9	TFF11-09	Guide	2
10	TFF11-10	A Frame Mount - Left	1
11	BM101580	Bolt- M10 x 1.5 x 80	4
11	FW10	Flat Washer- M10	4
11	LNM1015	Self-locking Nut- M10 x 1.5	4

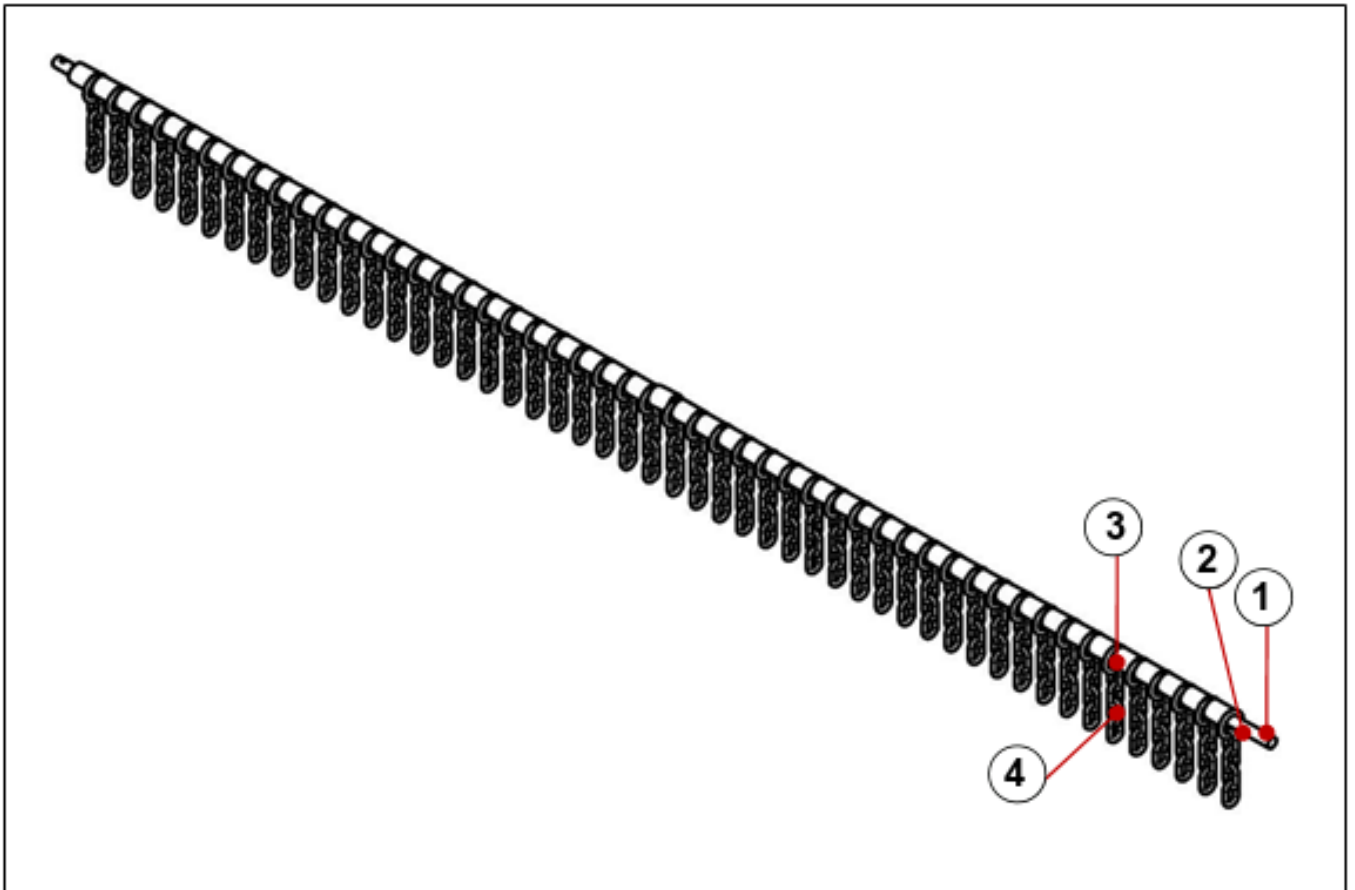

Figure 12 Front curtain

Pos.	Part #	Description	Qty
1	TFF12-01	Safety Pin	1
2	TFF12-02-180	Chain Rod - 180	1
2	TFF12-02-220	Chain Rod - 220	1
3	TFF12-03	Spacer	-
4	TFF12-04	Chain	-

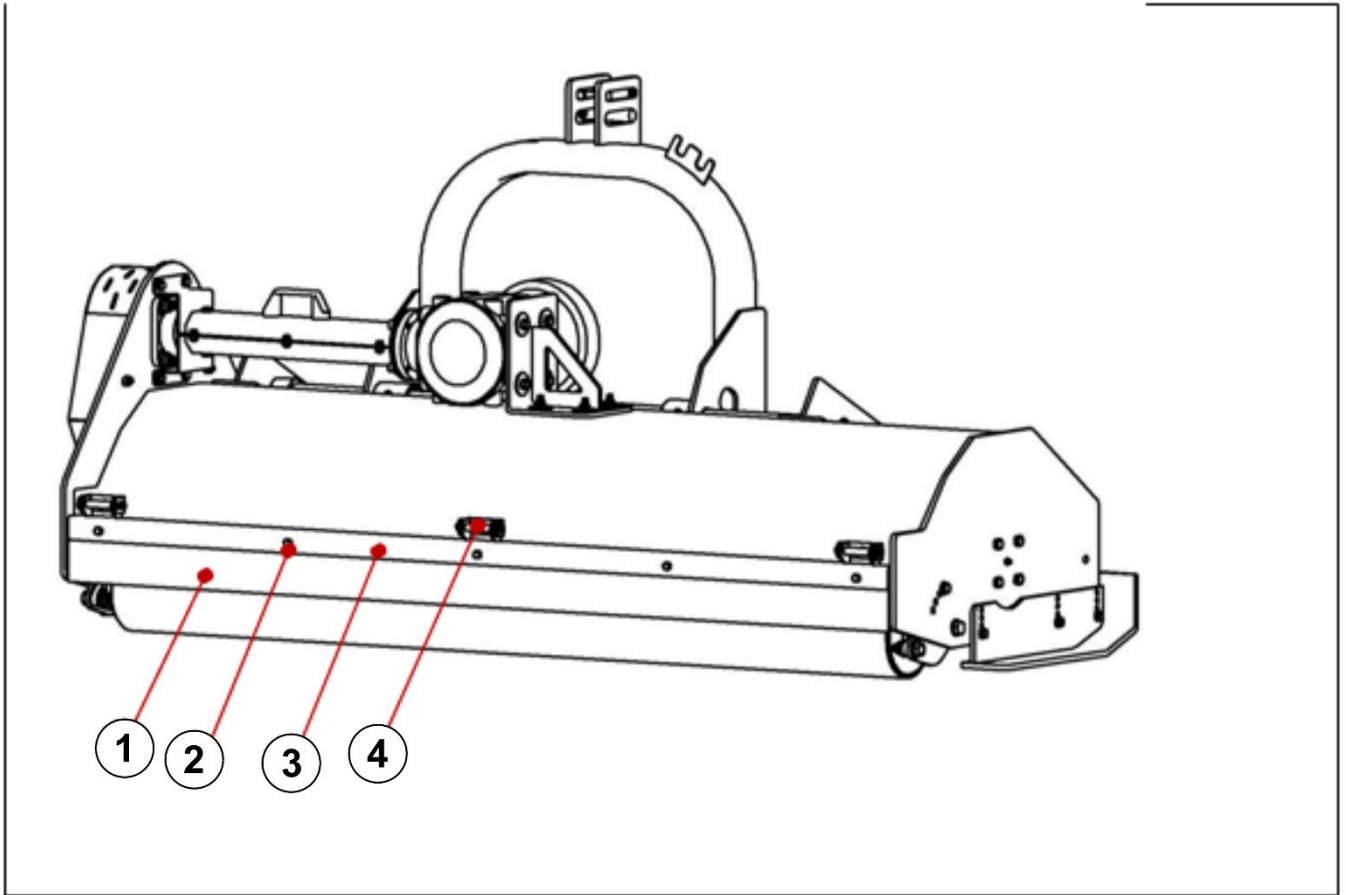

Figure 13 Rear curtain

Pos.	Part #	Description	Qty
1	TFF13-01-180	Rear Belting - 180	1
1	TFF13-01-220	Rear Belting - 220	1
2	TFF13-02-180	Support Bar - 180	1
2	TFF13-02-220	Support Bar - 220	1
3	BM812516	Bolt- M8 x 1.25 x 16	-
3	FW08	Flat Washer- M8	-
3	LNM8125	Self-Locking Nut- M8 x 1.25	-
4	TFF13-04	Pin Complete	3

LIMITED WARRANTY

Tar River Equipment warrants to the original purchaser of any new piece of machinery from Tar River Equipment, purchased from an **authorized** Tar River Equipment dealer, that the equipment be free from defects in material and workmanship for a period of one (1) year for non-commercial, state, and municipalities' use, ninety (90) days for commercial use from date of retail sale. Warranty for rental purposes is thirty (30) days. The **obligation** of Tar River Equipment to the purchaser under this warranty is limited to the repair or replacement of defective parts.

Replacement or repair parts installed in the equipment covered by this limited warranty are warranted for ninety (90) days from the date of purchase of such part **or** to the expiration of the applicable new equipment warranty period, whichever **occurs** later. Warranted parts shall be provided at no cost to the user at an **authorized** Tar River Equipment dealer during regular working hours. Tar River Equipment reserves the right to inspect any **equipment** or parts which are claimed to have been defective in material or workmanship.

This limited warranty does not apply to and excludes wear items such as **shear** pins, tires, tubes knives, blades, or other wear items. Oil or grease is not covered by this warranty.

All obligations of Tar River Equipment under this limited warranty shall be terminated if:

- Proper service is not performed on the machine.
- The machine is modified or altered in any way.
- The machine is being used or has been used for purposes other than those for which the machine was intended.

DISCLAIMER OF IMPLIED WARRANTIES & CONSEQUENTIAL DAMAGES

Tar River Equipment obligation under this limited warranty, to the extent allowed by law, is in lieu of all warranties, implied or expressed, including implied warranties of merchantability and fitness for a particular purpose and any liability for incidental and consequential damages with respect to the sale or use of the items warranted. Such incidental and consequential damages shall include but not be limited to transportation charges other than normal freight charges; cost of installation other than cost approved by Tar River Equipment; duty; taxes; charges for normal service or adjustment; loss of crops or any other loss of income; rental of substitute equipment, expenses due to loss, damage, detention, or delay in the delivery.