



RXT / BXV / CXT

Rotary Tillers

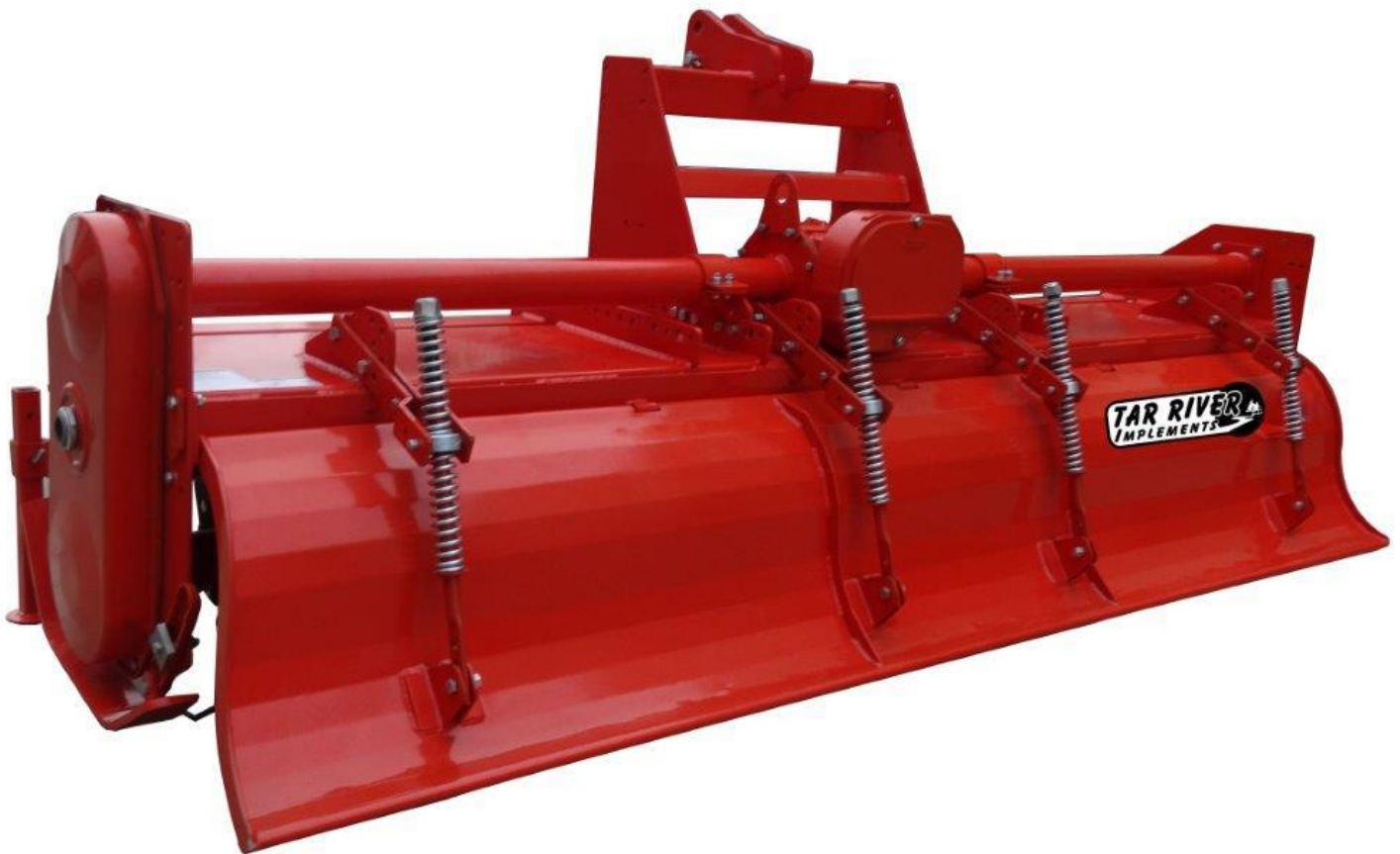

TABLE OF CONTENTS

INTRODUCTION	2
SAFETY.....	2
SAFETY SIGNAL WORDS	3
GENERAL SAFETY GUIDELINES	3
SAFETY DECAL CARE.....	4
BEFORE OPERATION.....	4
DURING OPERATION	5
HIGHWAY AND TRANSPORT OPERATIONS	6
OPERATION	8
FOLLOWING OPERATION.....	10
PREMORMING MAINTENANCE.....	10
MAINTENANCE	11
PARTS BREAKDOWN - RXT.	13-20
PARTS BREAKDOWN - BXV	21-28
PARTS BREAKDOWN - CXT.	29-42
PTO BREAKDOWN	43
LIMITED WARRANTY.....	46

INTRODUCTION

Thank you for purchasing your Tar River Equipment Tiller. Your rotary tiller is design to be used on 540 rpm tractors. It is important to properly maintain and keep in place all safety guards and shields that came with your tiller.

SAFETY

Read and understand this manual and all safety signs before operating and maintaining. Review the safety instructions and precautions annually.

TAKE NOTE! THIS SAFETY ALERT SYMBOL FOUND THROUGHOUT THIS MANUAL IS USED TO CALL YOUR ATTENTION TO INSTRUCTIONS INVOLVING YOUR PERSONAL SAFETY AND THE SAFETY OF OTHERS. FAILURE TO FOLLOW THESE INSTRUCTIONS CAN RESULT IN INJURY OR DEATH.



THIS SYMBOL MEANS

**ATTENTION!
BECOME ALERT!
YOUR SAFETY IS INVOLVED!**



SAFETY SIGNAL WORDS

Note the use of the signal words DANGER, WARNING and CAUTION with the safety messages. The appropriate signal word for each has been selected using the following guidelines:



DANGER: Indicates an imminently hazardous situation that, if not avoided, will result in death or serious injury. This signal word is to be limited to the most extreme situations typically for machine components which, for functional purposes, cannot be guarded.



WARNING: Indicates a potentially hazardous situation that, if not avoided, could result in death or serious injury, and includes hazards that are exposed when guards are removed. It may also be used to alert against unsafe practices.



CAUTION: Indicates a potentially hazardous situation that, if not avoided, may result in minor or moderate injury. It may also be used to alert against unsafe practices.



GENERAL SAFETY GUIDELINES

Safety of the operator is one of the main concerns in designing and developing a new piece of equipment. Designers and manufacturers build in as many safety features as possible. However, every year many accidents occur which could have been avoided by a few seconds of thought and a more careful approach to handling equipment. You, the operator, can avoid many accidents by observing the following precautions in this section. To avoid personal injury, study the following precautions and insist those working with you, or for you, follow them.

Replace any CAUTION, WARNING, DANGER or instruction safety decal that is not readable or is missing. Location of such decals is indicated in this booklet.

Do not attempt to operate this equipment under the influence of drugs or alcohol.

Review the safety instructions with all users annually.

This equipment is dangerous to children and persons unfamiliar with its operation. The operator should be a responsible adult familiar with farm machinery and trained in this equipment's operations. **Do not allow persons to operate or assemble this unit until they have read this manual and have developed a thorough understanding of the safety precautions and of how it works.**

To prevent injury or death, use a tractor equipped with a Roll Over Protective System (ROPS). Do not paint over, remove or deface any safety signs or warning decals on your equipment. Observe all safety signs and practice the instructions on them.

Never exceed the limits of a piece of machinery. If its ability to do a job, or to do so safely, is in question - **DON'T TRY IT.**



SAFETY DECAL CARE

- Keep safety signs clean and legible at all times.
- Replace safety signs that are missing or have become illegible.
- Replaced parts that displayed a safety sign should also display the current sign.
- Safety signs are available from your Distributor or Dealer Parts Department or the factory.

How to Install Safety Signs:

- Be sure that the installation area is clean and dry.
- Decide on the exact position before you remove the backing paper.
- Remove the smallest portion of the split backing paper.
- Align the decal over the specified area and carefully press the small portion with the exposed sticky backing in place.
- Slowly peel back the remaining paper and carefully smooth the remaining portion of the decal in place.
- Small air pockets can be pierced with a pin and smoothed out using the piece of decal backing paper.



BEFORE OPERATION

- Carefully study and understand this manual.
- Do not wear loose-fitting clothing, which may catch in moving parts.
- Always wear protective clothing and substantial shoes.
- Assure that all tires are inflated evenly.
- Give the unit a visual inspection for any loose bolts, worn parts or cracked welds, and make necessary repairs. Follow the maintenance safety instructions included in this manual.
- Be sure that there are no tools lying on or in the equipment.
- Do not use the unit until you are sure that the area is clear, especially children and animals.

- Don't hurry the learning process or take the unit for granted. Ease into it and become familiar with your new equipment.
- Practice operation of your equipment and its attachments. Completely familiarize yourself and other operators with its operation before using.
- Use a tractor equipped with a Roll Over Protective System (ROPS) and fasten your seat belt prior to starting the engine.
- The manufacturer does not recommend usage of tractor with ROPS removed.
- Move tractor wheels to the widest recommended settings to increase stability.
- Securely attach to towing unit. Use a high strength, appropriately sized hitch pin with a mechanical retainer and attach safety chain.
- Do not allow anyone to stand between the tongue or hitch and the towing vehicle when backing up to the equipment.



DURING OPERATION

- Children should not be allowed on the product.
- Clear the area of small children and bystanders before moving the feeder.
- If using a towing unit, securely attach feeder by using a hardened 3/4" pin, a metal retainer, and safety chains if required. Shift towing unit to a lower gear before going down steep downgrades, thus using the engine as a retarding force. Keep towing vehicle in gear at all times. Slow down for corners and rough terrain.
- Make sure you are in compliance with all local and state regulations regarding transporting equipment on public roads and highways. Lights and slow moving signs must be clean and visible by overtaking or oncoming traffic when feeder is transported.
- Beware of bystanders, **particularly children!** Always look around to make sure that it is safe to start the engine of the towing vehicle or move the unit. This is particularly important with higher noise levels and quiet cabs, as you may not hear people shouting.
- **NO PASSENGERS ALLOWED** - Do not carry passengers anywhere on, or in, the tractor or equipment, except as required for operation.
- Keep hands and clothing clear of moving parts.
- Do not clean, lubricate or adjust your equipment while it is moving.
- When halting operation, even periodically, set the tractor or towing vehicle brakes, disengage the PTO, shut off the engine and **remove the ignition key.**
- Be especially observant of the operating area and terrain - watch for holes, rocks or other hidden hazards. Always inspect the area prior to operation.

- **DO NOT** operate near the edge of drop-offs or banks.
- **DO NOT** operate on steep slopes as overturn may result.
- Operate up and down (not across) intermediate slopes. Avoid sudden starts and stops.



HIGHWAY AND TRANSPORT OPERATIONS

- Adopt safe driving practices:
- Keep the brake pedals latched together at all times. **NEVER USE INDEPENDENT BRAKING WITH MACHINE IN TOW AS LOSS OF CONTROL AND/OR UPSET OF UNIT CAN RESULT.**
- Always drive at a safe speed relative to local conditions and ensure that your speed is low enough for an emergency stop to be safe and secure. Keep speed to a minimum.
- Reduce speed prior to turns to avoid the risk of overturning.
- Avoid sudden uphill turns on steep slopes.
- Always keep the tractor or towing vehicle in gear to provide engine braking when going downhill. Do not coast.
- Do not drink and drive!
- Comply with state and local laws governing highway safety and movement of farm machinery on public roads.
- Use approved accessory lighting flags and necessary warning devices to protect operators of other vehicles on the highway during daylight and nighttime transport. Various safety lights and devices are available from your dealer.
- The use of flashing amber lights is acceptable in most localities. However, some localities prohibit their use. Local laws should be checked for all highway lighting and marking requirements.
- When driving the tractor and equipment on the road or highway under 40 kph (20 mph) at night or during the day, use flashing amber warning lights and a slow moving vehicle (SMV) identification emblem.
- Plan your route to avoid heavy traffic.
- Be a safe and courteous driver. Always yield to oncoming traffic in all situations, including narrow bridges, intersections, etc.
- Be observant of bridge loading ratings. Do not cross bridges rated lower than the gross weight as which you are operating.

- Watch for obstructions overhead and to the side while transporting.
- Always operate equipment in a position to provide maximum visibility at all times. Make allowances for increased length and weight of the equipment when making turns, stopping the unit, etc.
- Pick the levellest possible route when transporting across fields. Avoid the edges of ditches or gullies and steep hillsides.
- Be extra careful when working on inclines.
- Maneuver the tractor or towing vehicle at safe speeds.
- Avoid overhead wires or other obstacles. Contact with overhead lines could cause serious injury or death.
- Avoid loose fill, rocks and holes; they can be dangerous for equipment operation or movement.
- Allow for unit length when making turns.
- Operate the towing vehicle from the operator's seat only.
- Never stand alongside of unit with engine running or attempt to start engine and/or operate machine while standing alongside of unit.
- Never leave running equipment attachments unattended.
- As a precaution, always recheck the hardware on equipment following every 100 hours of operation. Correct all problems. Follow the maintenance safety procedures.

Operation



Before attaching the rotary tiller to the tractor, check the unit to ensure there is oil in the top and side gearbox and the right rotor bearing. See Maintenance section for lubricant specifications.

Before beginning operation, check oil and grease points.

Oil level: Center gearbox 1/2" on the dip stick.
When sitting slightly tilted forward, oil should be at the bottom of the drain plug on the side gearbox cover.
Right Rotor bearing, fill to level or approximately 1/2 full.

Grease: PTO shaft Cross & Bearings



Attaching to the tractor

1. With the Rotary Tiller on a level surface, back the Cat. 1 or 2 tractor so the tractor lift arms are even with the unit's lower hitch pins. Lower or raise the tractor hitch arms until the 7/8" bushing in the arm is inside the clevis of lower hitch points. **Be sure nothing is between the tractor and the tiller before backing up.**
2. Insert the lower hitch pin through the lower hitch blocks and the tractor arm. The YCT series tillers have adjustable lower hitch blocks that can be slide to facilitate usage on larger tractors.
3. Secure the lift arm in place by using a 7/16" lynch pin or other fastener.
4. Repeat with the other arm.
5. Connect the driveline to the tractor's PTO output shaft. Secure it in place.
6. Connect the tractor top link to the upper hitch point of the rotary tiller.
7. Start the tractor and slowly raise the tiller. Check for drawbar interference. Be sure that the PTO driveline does not bottom out when lifting the machine to its maximum height. If it does appear that it could bottom out, it is necessary to shorten the PTO driveline. (See Shortening a PTO Driveline section). Ensure that in the working position there is an overlap of a minimum of 1/3 the length of each profile.

Shortening a PTO Driveline

1. With the implement attached to the tractor's three point hitch, and the PTO driveline not installed, separate the PTO driveline. Attach the implement end to the implement and the other end to the tractor PTO input shaft.
2. Raise the implement by using the tractor's hydraulic 3-point hitch to its maximum lift height.
3. Hold the half shafts next to each other and mark them so each end is approximately 1/2" from hitting the end of the telescopic profiles.
4. Shorten the inner and out guard tubes equally.
5. Shorten the inner and outer profiles by the same length as the guard tubes. Using a rattle file, round off all sharp edges and burrs. Grease the telescopic profile generously before reassembling.

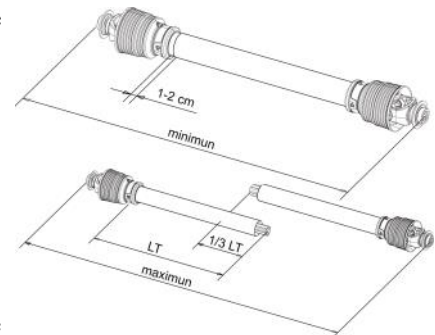



Do not shorten too much, the proper overlap is a minimum of 1/3 the length of each profile.

Caution: Slip Clutches may become hot. Do Not Touch. Keep the slip clutch area clear of an material that may catch fire.

Slip clutches have adjustable torque settings. The torque setting varies with the different compression of each spring. All the springs should have an equal amount of compression.

IMPORTANT: Do not over-tighten the compression nuts as this may impair performance or cause premature wearing of the slip clutch.

Slip Clutch adjustments

Slip Clutch must be adjusted before first use or after a storage period.

1. Using a marker, scribe a line across the exposed edges of the clutch plate and friction discs.
2. Back off compression nuts to free friction discs by turning each nut *exactly* 2 revolutions.
3. Start the tractor and run the driveline at a low idle to slip the friction discs. This will remove the dirt, corrosion and surface floss from the clutch plate faces.
4. Disengage PTO, shut down tractor and wait for all components to come to a complete stop.
5. Inspect the clutch and ensure that the scribed markings on the disc and plates have changed position. If any two marks are still aligned, this is an indication that these discs have not slipped. It may be necessary to completely disassemble the clutch to free them up.
6. After ensuring all discs are free, tighten the compression nuts, uniformly, *exactly* 2 revolutions to reset the clutch original pressure, where the springs are 1 1/4" compressed length..

Working Depth Adjustment

The working depth is controlled by raising or lowering the side skids. If the skids are raised, the working depth increases. By lowering the skids, the tilling depth with decrease.

Tailgate adjustment

Position the tailgate to its desired opening by fitting the bolts into the appropriate holes of the adjustment flange located on the top of the main frame. To adjust the degree of tension, tighten or loosen up on the 24mm nut on the top of the spring support rod.



Multi-Speed Gearbox

On certain models, the tiller will come standard with a multi-speed gearbox to allow rotor speed changes. This is very useful on uneven ground so the tractor speed can maintain a constant ground speed and change the rotor speed in order to adapt to different soil conditions.

In order to change the rotor speed:

1. Ensure the gearbox is not too hot to work safely without burning ones hands.
2. Tilt the tiller forward to prevent excessive oil from coming out of the back cover.
3. Unscrew the bolt holding the rear cover of the gearbox.
4. Adjust the gears inside the gearbox in order to obtain the desired speed.
5. Replace cover and tighten bolts.
6. **IMPORTANT: Make sure the spacers located behind the gears do not fall into the gearbox! If this happens damage to the gearbox or gears can occur.**



Gear Adjustment

BXV				CXT			
INPUT	Left Gear	Right Gear	Rotor Speed	INPUT	Left Gear	Right Gear	Rotor Speed
540	22	16	140	540	23	17	143
540	20	18	174	540	21	19	175
540	18	20	213	540	19	21	214
540	16	22	266	540	17	23	262

Start up

After making the necessary adjustments, lower the rotary tiller until the blades are a couple of inches from the ground. Engage the PTO and slowly lower the tiller to begin working.

Removal and Storage

After finishing, remove the rotary tiller from the tractor.

1. Put the PTO driveline in a safe location so it will not become damaged.
2. Clean and dry the equipment.
3. Replace any damaged or worn parts.
4. Check all bolts and nuts for tightness.
5. Lubricate and protect the machine from the elements.



FOLLOWING OPERATION

- Following operation, or when unhitching, stop the tractor or towing vehicle, set the brakes, disengage the PTO and all power drives, shut off the engine and **remove the ignition keys**.
- Store the unit in an area away from human activity.
- Do not park equipment where it will be exposed to livestock for long periods of time. Damage and livestock injury could result.
- Do not permit children to play on or around the stored unit.
- Make sure all parked machines are on a hard, level surface and engage all safety devices.
- Wheel chocks may be needed to prevent unit from rolling.



PERFORMING MAINTENANCE

- Good maintenance is your responsibility. Poor maintenance is an invitation to trouble.
- Make sure there is plenty of ventilation. Never operate the engine of the towing vehicle in a closed building. The exhaust fumes may cause asphyxiation.
- Be certain all moving parts on attachments have come to a complete stop before attempting to perform maintenance.
- Always use the proper tools or equipment for the job at hand.
- Use extreme caution when making adjustments.
- Never replace hex bolts with less than grade five bolts unless otherwise specified.
- After servicing, be sure all tools, parts and service equipment are removed.
- Where replacement parts are necessary for periodic maintenance and servicing, genuine factory replacement parts must be used to restore your equipment to original specifications. The manufacturer will not

claim responsibility for use of unapproved parts and/or accessories and other damages as a result of their use.

- If equipment has been altered in any way from original design, the manufacturer does not accept any liability for injury or warranty.

MAINTENANCE

8 hours

Check oil in Rotor (*90wt*)
Grease PTO shaft cross & bearings (*GP grease*)
Check Hardware for tightness

16 hours

Check oil level in center gearbox (*90wt*)
Check oil level in side gearbox (*140wt*)
Check oil level in rotor. (*90wt*)
Check Hardware for tightness

200 hours

Replace oil in center gearbox (*90wt*)
Replace oil in side gearbox (*140wt*)
Check Hardware for tightness

Replacing Blades

In order for the tiller to perform optimally, make sure the tiller blades are in good working condition and their bolts and nuts tight. Always replace the blades with the bolt head against the blade and the washer and nut on the flange side to help prevent the blades from loosening.

When several blades are to be replaced, replace them one blade at a time in order maintain the scroll pattern on the rotor.

Note: To determine Left or Right Blades, hold the blade by the bolt hole end and the cutting edge facing downward. If the blade curves to the left it is a left hand blade, curving to the right indicates a right hand blade.

Tar River Equipment

RXT-080 - RXT-088 - RXT-096 (Version 1-2)

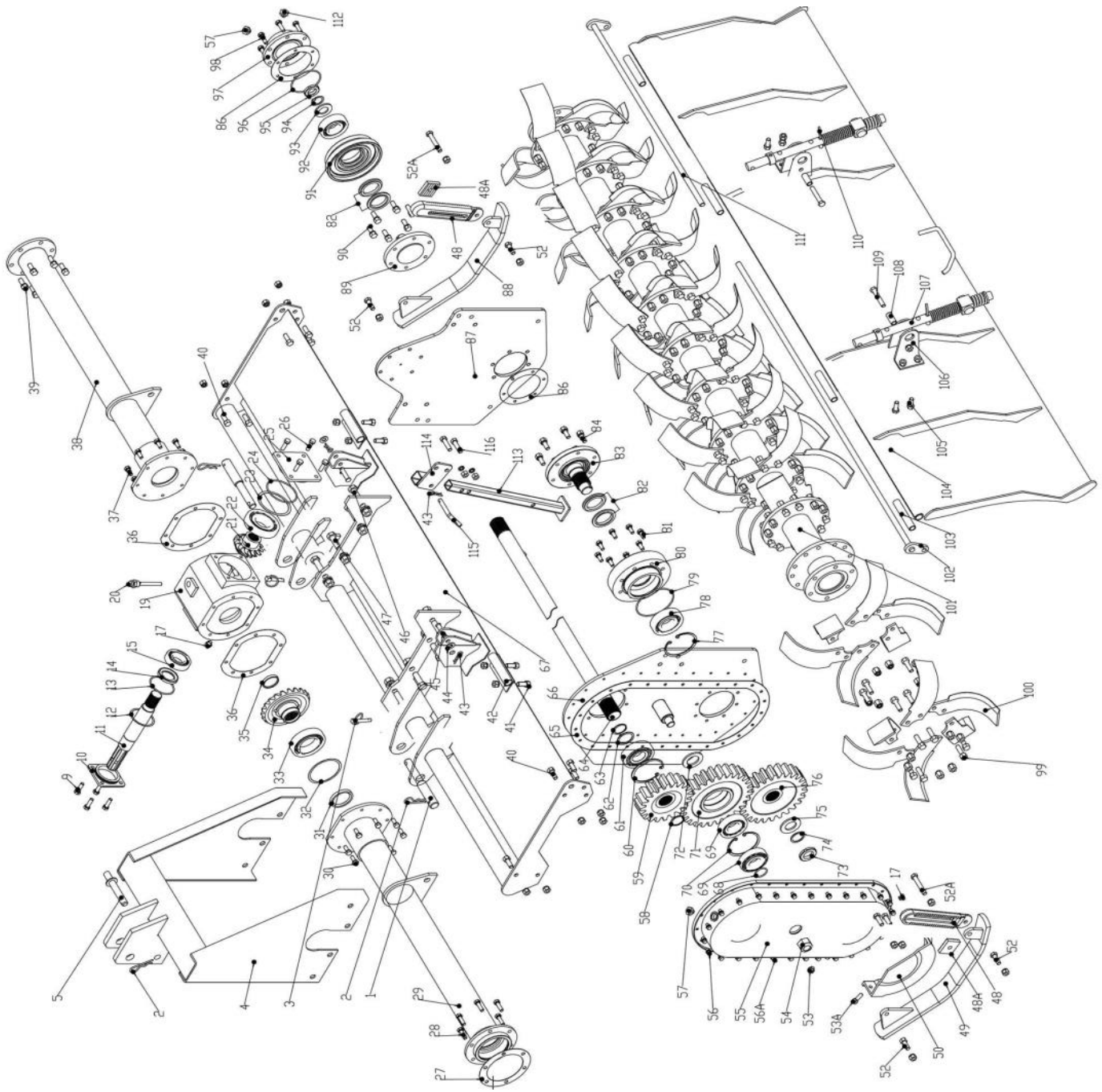

Tar River Equipment

RXT-080 - RXT-088 - RXT-096 (Version 1-2)

POS.	Part #	Description	Qty
1	SB100755	Lower Hitch Pin - Cat. 1 & 2	2
2	RC400000	"R" Clip 4mm	4
3	SB100756	Lynch pin	2
4	RX0100	A Frame	1
5	YT1066010204	Top Hitch Pin Cat. 1	1
9	BM101520	Bolt - 10 x 1.5 x 20	4
9A	RX0304-1	Shield - Gearbox	1
9B	BM812516	Bolt - 8 x 1.25 x 16	3
9C	RX0304-2	Shield Support - Gearbox	1
10	RX0310	Cap - Front Gearbox	1
11	RX0309	Input Shaft	1
12	OR75355	O Ring 75 x3.55	1
13	RX0311	Shim-Input Cap 80*70*0.4	2
14	OS406508	Oil Seal 40 x 65 x 8	1
15	B6208	Bearing - 6208	1
16	RX0016	Shim-Input Bearing 50*40*2	1
17	OP1212500	Oil Plug 12mm	2
18	SRE40000	Snap Ring - Pinion Gear - Front	1
19	RX0305	Housing - Gearbox	1
20	YT10660303000	Gearbox Oil Plug	1
21	RX0308	Pinion Gear	1
22	B30310	Bearing 30310	1
23	RX0306	Gearbox Back Gasket	2
24	OR3555	O-Ring - 35x5.5	1
25	RX0307	Gearbox Cap	1
26	BM101525	Bolt 10 x 1.5 x 25	4
27	RX0315	Gasket - Drive shaft	1
28	BM101525	Bolt 10 x 1.5 x 25	6
29	RX0301-80	Drive Shaft Tube Housing RXT-080	1
29	RX0301-88	Drive Shaft Tube Housing RXT-088	1
29	RX0301-96	Drive Shaft Tube Housing RXT-096	1
30	BM101525	Bolt 10 x 1.5 x 25	8
31	OS72559	Oil Seal - 72 X 55 X 9	1
32	RX0303	Gasket - Drive shaft tube housing	3
33	B6212	Bearing 6212	1
34	RX0304	Ring Gear	1
35	RX0904	Cap 52mm	1
36	RX0314	Gasket - Center Gearbox Left Side	2
37	BM1012530	Bolt 10 x 1.25 x 25	8
38	RX0905-80	Gearbox Support Tube - RXT-080	1
38	RX0905-88	Gearbox Support Tube - RXT-088	1
38	RX0905-96	Gearbox Support Tube - RXT-096	1
39	BM1217525	Bolt 12 x 1.75 x 25	8
40	BM1217535	Bolt 12 x 1.75 x 35	12
41	BM1217525	Bolt 12 x 1.75 x 25	4
42	RX0206	Hanger - Tailgate	2

Tar River Equipment

RXT-080 - RXT-088 - RXT-096 (Version 1-2)

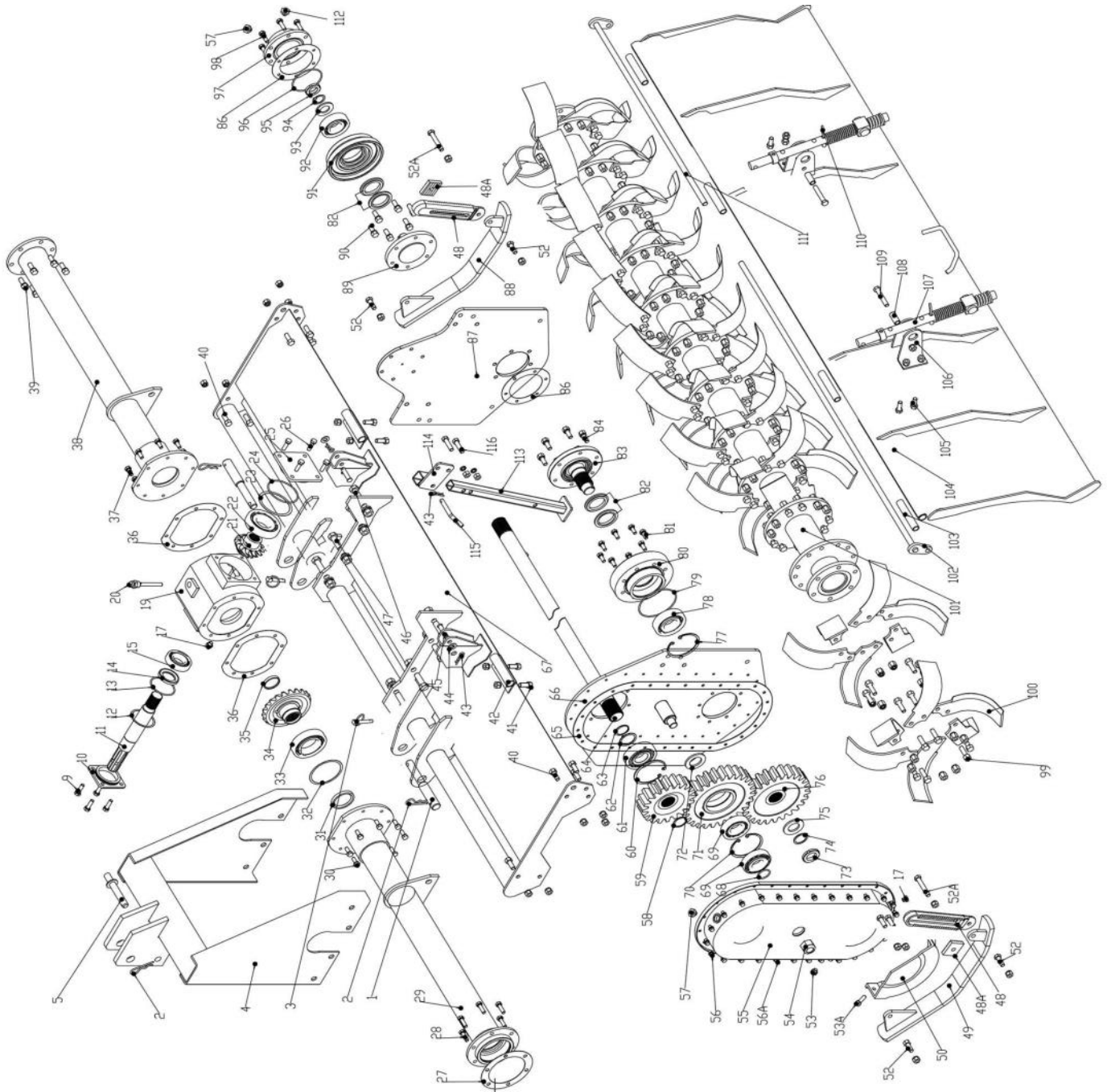

Tar River Equipment

RXT-080 - RXT-088 - RXT-096 (Version 1-2)

POS.	Part #	Description	Qty
43	RC300000	R-Clip - Tailgate Adjustment	2
45	RX0205	Pin - Tailgate Adjustment	2
46	BM162050	Bolt - 16 x 2.0 x 50	2
47	BM162040	Bolt - 16 x 2.0 x 40	6
48	RX0600	Skid Support (Version 1)	2
48	BV0801	Skid Adjustment Bracket (Version 2)	2
48A	BV0802	Skid Adjustment Stop (Version 2)	2
49	RX0601	Skid Weldment - Left (Version 1)	1
	RXG0601	Skid Weldment—Left (Version 2)	1
50	RX0502	Skid shield	1
51	RX0505	Skid Bracket	1
52	BM1217535	Bolt - 12 x 1.75 x 35	10
52A	BM1212560	Bolt - 12 x 1.25 x	2
53	OP1212500	Oil Plug 12mm	1
53A	BM1217520	Bolt 12 x 1.75 x 20	1
54	NM2415	Nut Lock - 24mm	1
55	RX0503	Side Drive Cover	1
56	BM812525	Bolt 8 x 1.25 x 25	23
56A	BM812516	Bolt 8 x 1.25 x 16	4
57	DP1615000V	Breather cap - Side housing	1
58	SRE45000	Snap Ring Ext. 45mm	1
59	RX0506	Top Gear	1
60	SRI100	Snap Ring - Top Gear Bearing	1
61	BNUP309E	Bearing BNUP309E	1
62	RX0301	Gasket - Driveside Top Gear	1
63	SRE45000	Snap Ring Ext. 45mm	1
64	RX0302-80	Drive Shaft - RXT-080	1
64	RX0302-88	Drive Shaft - RXT-088	
64	RX0302-96	Drive Shaft - RXT-096	
65	RX0500	Gasket - Side Gear Case	1
66	RX0501	Side Panel - Left (Version 1)	1
	RXG0501	Side Panel—Left (Version 2)	1
67	RX0201-80	Frame Weldment - RXT-080	1
67	RX0201-88	Frame Weldment - RXT-088	
67	RX0201-96	Frame Weldment - RXT-096	
68	OR3555	O-Ring - 35x5.5	1
69	B30307	Bearing 30307	2
70	SRI90000	Snap Ring Int. 90mm	1
71	RX0507	Idler Gear	1
72	RX0509	Spacer	1
73	T810-1998	Nut 36*1.5	2
74	SRE3500	Snap Ring Ext. 35mm	2

Tar River Equipment

RXT-080 - RXT-088 - RXT-096 (Version 1-2)

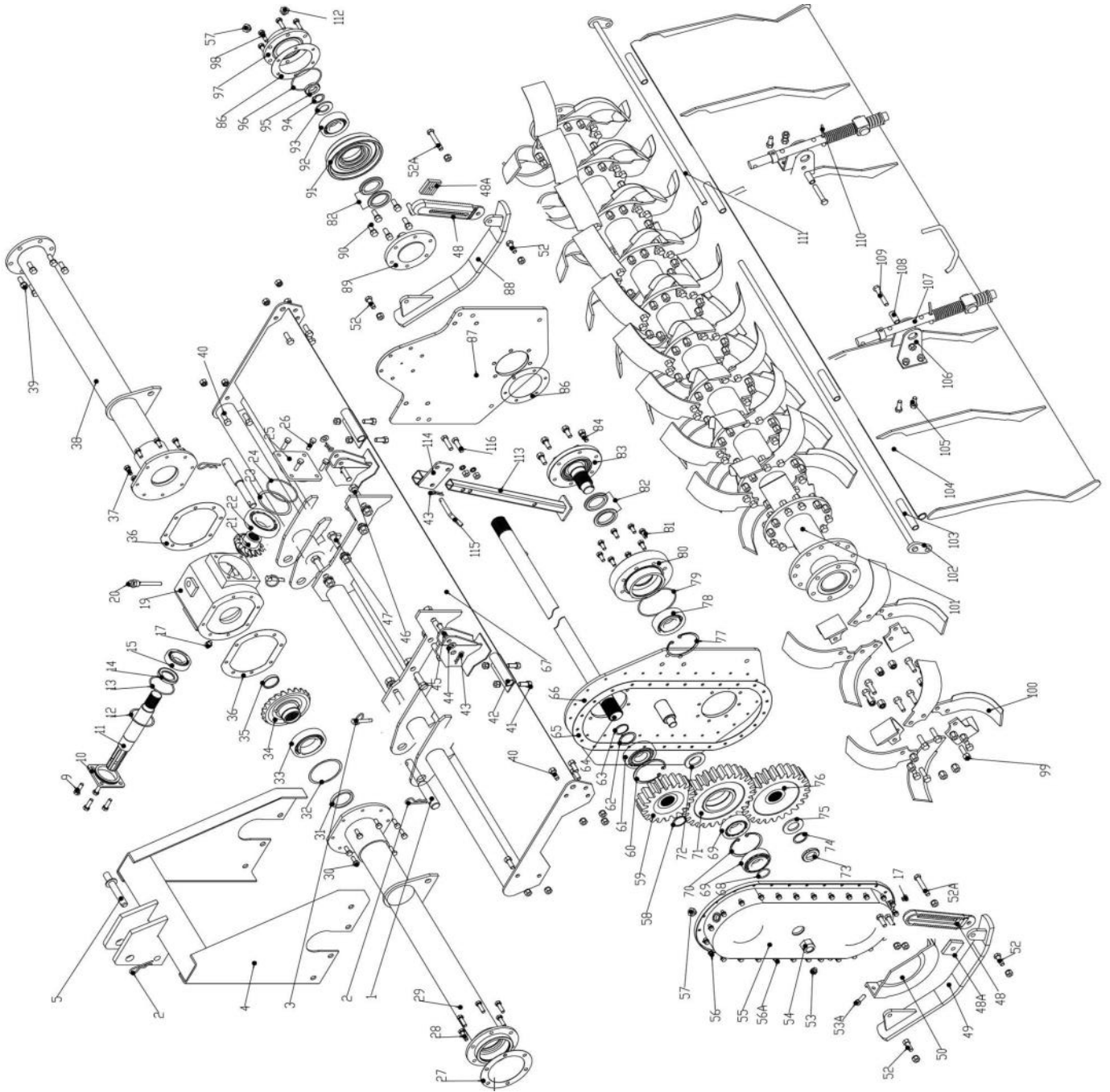

Tar River Equipment

RXT-080 - RXT-088 - RXT-096 (Version 1-2)

POS.	Part #	Description	Qty
75	FW3600	Flat Washer 36mm	1
76	RX0508	Bottom Gear	1
77	SRI100	Snap Ring Int. 100mm	1
78	B6309	Bearing - 6309	1
79	OR122355	O-Ring - - 122x 3.55	1
80	RX0402	Bearing Support - Left Side	1
81	BM101525	Bolt 10 x 1.5 x 25	8
82	OS76535085	Float Oil Seal-76 x 53.5 x 8.5	2
83	RX0401	Rotor Support shaft - Left side	1
84	BM1217530	Bolt - 12 x 1.75 x 30	6
85	RX0204	Protector - Right Side	1
86	RX0406	Gasket - Rotor	2
87	RX0201	Side Panel - Right (Version 1)	1
	RXGU0201	Side Panel—Right (Version 2)	
88	RX0602	Skid Weldment - Right (Version 1)	1
	RXG0602	Skid Weldment—Right (Version 2)	
89	RX0403	Rotor Support shaft - Right side	1
90	BM101530	Bolt 10 x 1..5 x 30	6
91	RX0404	Bearing Support	1
92	B6308	Bearing - 6308	1
93	FW3000	Flat Washer 30mm	1
94	SRE30000	Snap Ring Ext. 30mm	1
95	SNM30150	Spanner Nut 30x 1.5	1
96	OR925355	O Ring - 92.5 x 3.55	1
97	RX0405	End Cap - Rotor Right side	1
98	BM101535	Bolt 10 x 1.5 x 35	6
99	BM141540	Bolt - 14 x 1.5 x 40	-
	NM140001	Nut 14mm—Fine Thread	-
100	RX0407L	Blade - Left (Version 1)	30-33-36
100	RX0407R	Blade - Right (Version 1)	30-33-36
100	RXU0407L	Blade - Left (Version 2)	28-30-33
100	RXU0407R	Blade - Right (Version 2)	28-30-33
101	RX0401-80	Rotor -RXT-080 (Version 1)	1
101	RX0401-88	Rotor -RXT-088 (Version 1)	1
101	RX0401-96	Rotor -RXT-096 (Version 1)	1
101	RXU0401-80	Rotor -RXT-080 (Version 2)	1
101	RX0U401-88	Rotor -RXT-088 (Version 2)	1
101	RX04U01-96	Rotor -RXT-096 (Version 2)	1
102	RX0701L-80	Rod - Tailgate RXT-080 Left	1
102	RX0701L-88	Rod - Tailgate RXT-088 Left	1
102	RX0701L-96	Rod - Tailgate RXT-096 Left	1
103	RX0708	Rod Tube - Nylon	1

Tar River Equipment

RXT-080 - RXT-088 - RXT-096 (Version 1-2)

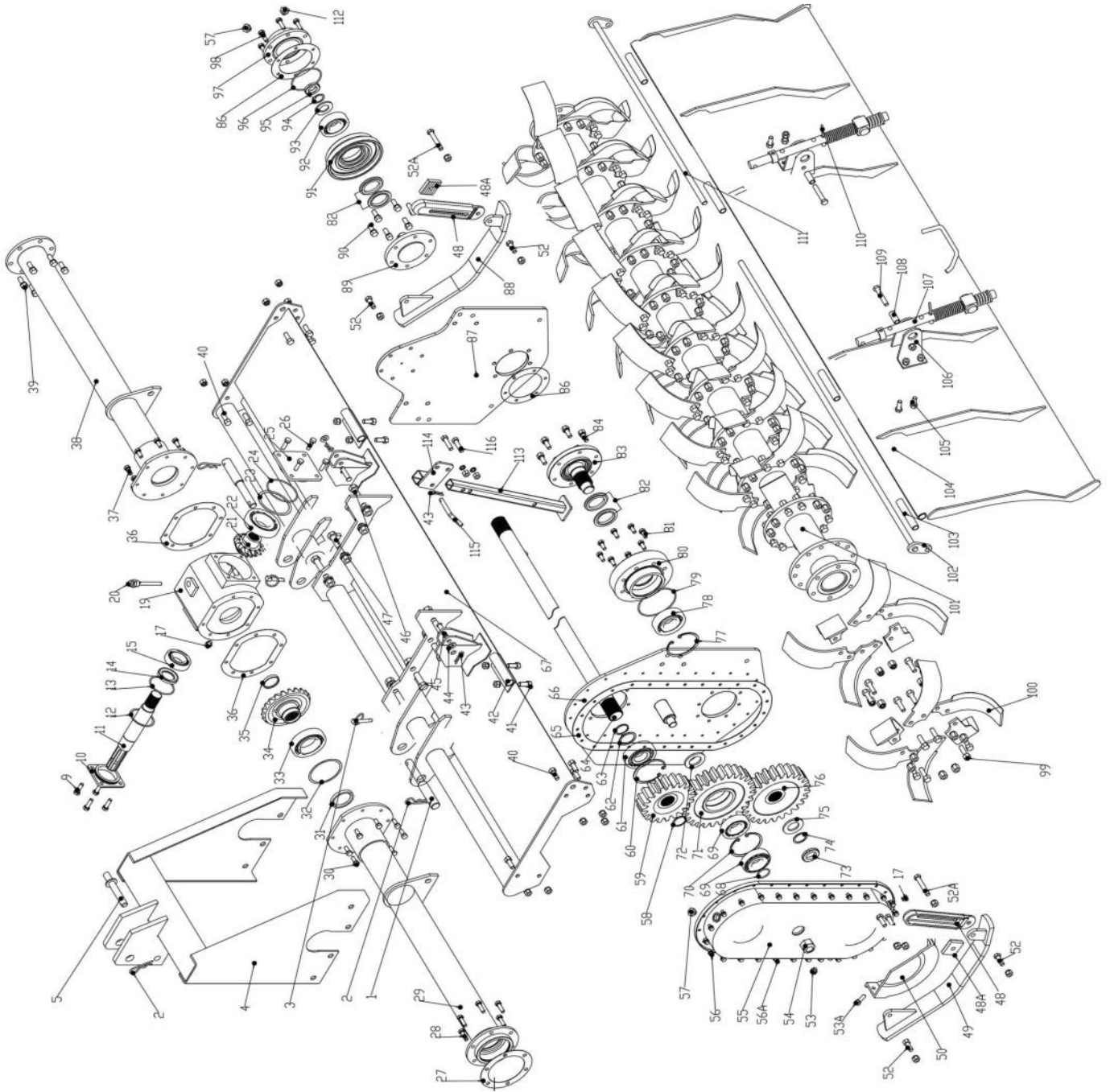

Tar River Equipment

RXT-080 - RXT-088 - RXT-096 (Version 1-2)

POS.	Part #	Description	Qty
104	RX0702-80	Tailgate RXT-080	1
104	RX0702-88	Tailgate RXT-088	1
104	RX0702-96	Tailgate RXT-096	1
105	BM1217525	Bolt- 12 x 1.75 x 25	4
106	RX0702	Bracket - Tailgate Spring	2
107	RX0703	Rod - Tailgate Spring	2
108	RX0701	Bushing - Tailgate	2
109	BM1217570	Bolt-12 x 1.75 x 70	2
110	RX0707	Spring - Tailgate	4
111	RX0701R-80	Rod - Tailgate RXT-080 Right	1
111	RX0701R-88	Rod - Tailgate RXT-088 Right	1
111	RX0701R-96	Rod - Tailgate RXT-096 Right	1
113	RX0801	Stand	1
114	RX0802	Bracket—Stand	1
115	YT10660501	Pin	1
116	BM1217530	Bolt 12 x 1.75 x 30	2
	147125	Complete PTO - Series 60 - 200mm Slip Clutch	
	180-510-60 WE970-4160	Friction Disc - 6 1/3"OD	

Tar River Equipment

RXT-080 - RXT-088 - RXT-096 (Version 3)

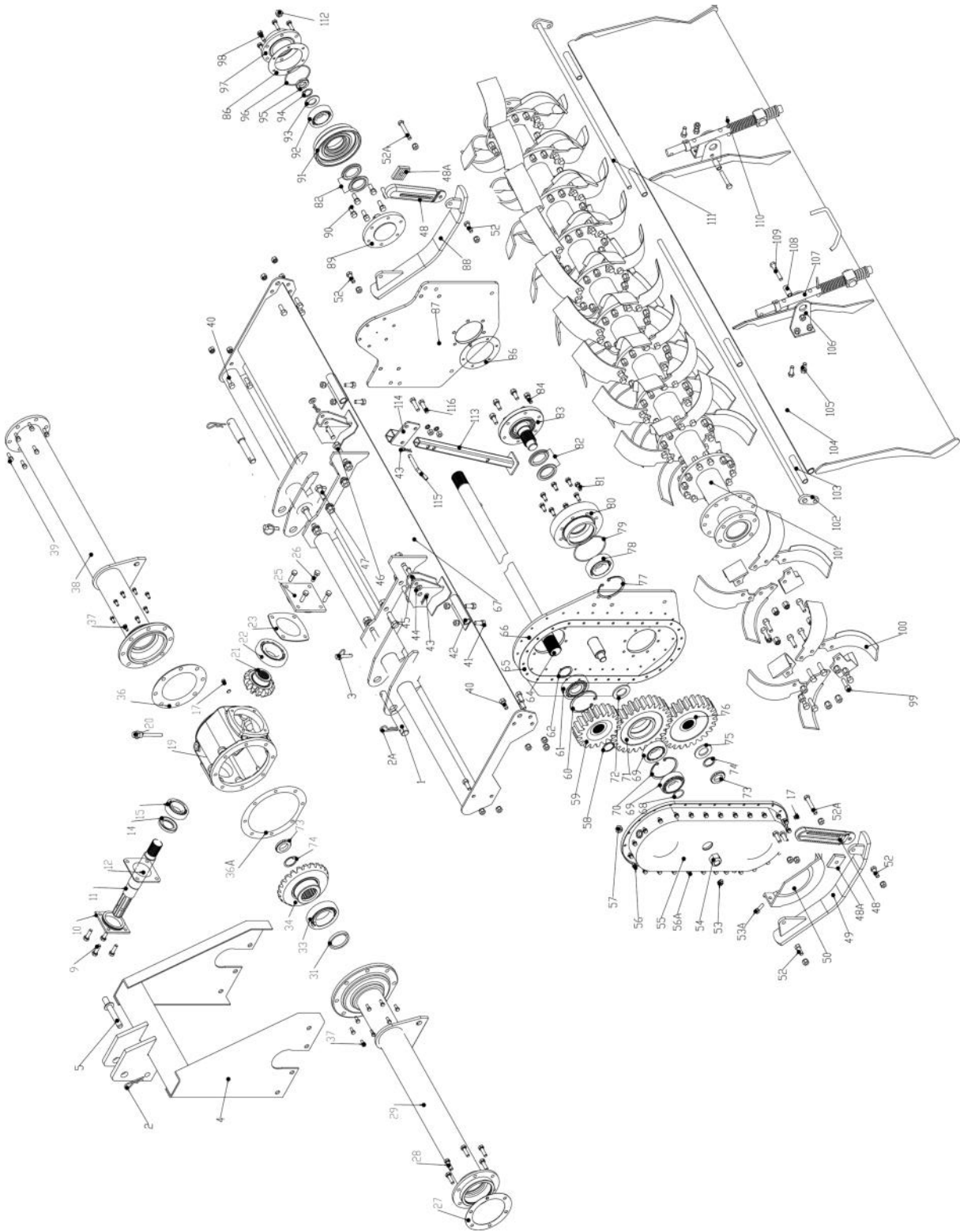

Tar River Equipment

RXT-080 - RXT-088 - RXT-096 (Version 3)

POS.	Part #	Description	Qty
1	SB100755	Lower Hitch Pin - Cat. 1 & 2	2
2	RC400000	"R" Clip 4mm	4
3	SB100756	Lynch pin	2
4	RXA0100	A Frame	1
5	YT1066010204	Top Hitch Pin Cat. 1	1
9	BM101520	Bolt - 10 x 1.5 x 20	4
9A	RX0304-1	Shield - Gearbox	1
9B	BM812516	Bolt - 8 x 1.25 x 16	3
9C	RX0304-2	Shield Support - Gearbox	1
10	RX0A310	Cap - Front Gearbox	1
11	RXA0309	Input Shaft	1
12	RX0906	Gasket-Input Shaft	1
14	OS406508	Oil Seal 40 x 65 x 8	1
15	B30208	Bearing - 30208	1
17	OP1212500	Oil Plug 12mm	2
19	RXA0305	Housing - Gearbox	1
20	YT10660303000	Gearbox Oil Plug	1
21	RXA0308	Pinion Gear	1
22	B30212	Bearing 30212	1
23	RXA0306	Gearbox Back Gasket	2
25	RXA0307	Gearbox Cap	1
26	BM101530	Bolt 10 x 1.5 x 30	4
27	RX0315	Gasket - Drive shaft	1
28	BM101525	Bolt 10 x 1.5 x 25	6
29	RX0301-80	Drive Shaft Tube Housing RXT-080	1
29	RX0301-88	Drive Shaft Tube Housing RXT-088	1
29	RX0301-96	Drive Shaft Tube Housing RXT-096	1
30	BM101525	Bolt 10 x 1.5 x 25	8
31	OS458012	Oil Seal - 45 X 80 X 12	1
33	B6217	Bearing 6217	1
34	RXA0304	Ring Gear	1
36	RX0907	Gasket - Center Gearbox Right Side	1
36A	RXA0314	Gasket - Center Gearbox Left Side	1
37	BM1012530	Bolt 10 x 1.25 x 25	8
38	RX0905-80	Gearbox Support Tube - RXT-080	1
38	RX0905-88	Gearbox Support Tube - RXT-088	1
38	RX0905-96	Gearbox Support Tube - RXT-096	1
39	BM1217525	Bolt 12 x 1.75 x 25	8
40	BM1217535	Bolt 12 x 1.75 x 35	12

Tar River Equipment

RXT-080 - RXT-088 - RXT-096 (Version 3)

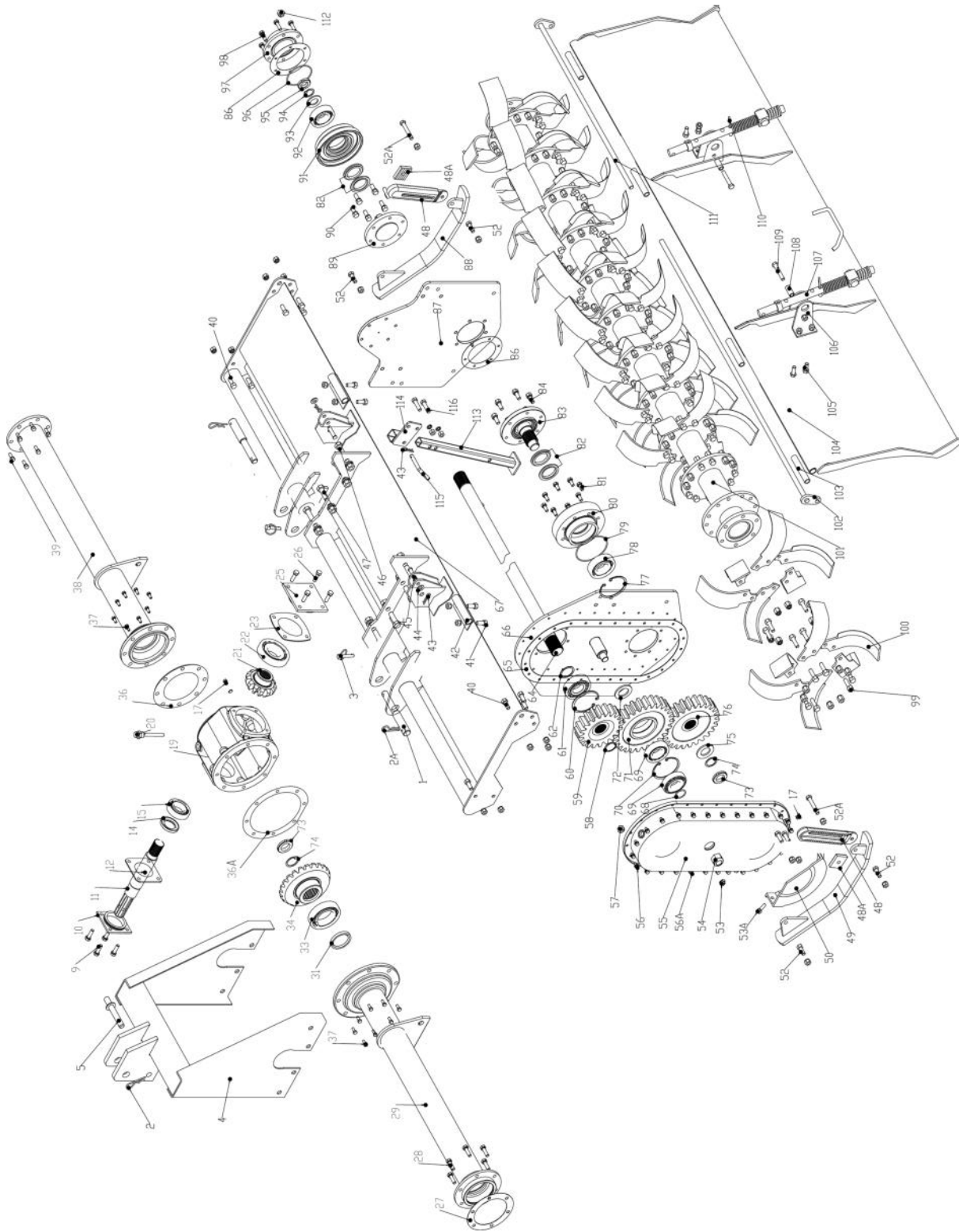

Tar River Equipment

RXT-080 - RXT-088 - RXT-096 (Version 3)

POS.	Part #	Description	Qty
41	BM1217525	Bolt 12 x 1.75 x 25	4
42	RX0206	Hanger - Tailgate	2
43	RC300000	R-Clip - Tailgate Adjustment	2
45	RX0205	Pin - Tailgate Adjustment	2
46	BM162050	Bolt - 16 x 2.0 x 50	2
47	BM162040	Bolt - 16 x 2.0 x 40	6
48	RX0600	Skid Support	2
48	BV0801	Skid Adjustment Bracket (SN 10600 +)	2
48A	BV0802	Skid Adjustment Stop	2
49	RX0601	Skid Weldment - Left	1
	RXG0601	Skid Weldment—Left (SN 10600 +)	1
50	RX0502	Skid shield	1
51	RX0505	Skid Bracket	1
52	BM1217535	Bolt - 12 x 1.75 x 35	10
52A	BM1212560	Bolt - 12 x 1.25 x	2
53	OP1212500	Oil Plug 12mm	1
53A	BM1217520	Bolt 12 x 1.75 x 20	1
54	NM2415	Nut Lock - 24mm	1
55	RX0503	Side Drive Cover	1
56	BM812525	Bolt 8 x 1.25 x 25	23
56A	BM812516	Bolt 8 x 1.25 x 16	4
57	DP1615000V	Breather cap - Side housing	1
58	SRE45000	Snap Ring Ext. 45mm	1
59	RX0506	Top Gear	1
60	SRI100	Snap Ring - Top Gear Bearing	1
61	BNUP309E	Bearing BNUP309E	1
62	RX0301	Gasket - Driveside Top Gear	1
63	SRE45000	Snap Ring Ext. 45mm	1
64	RX0302-80	Drive Shaft - RXT-080	1
64	RX0302-88	Drive Shaft - RXT-088	
64	RX0302-96	Drive Shaft - RXT-096	
65	RX0500	Gasket - Side Gear Case	1
66	RX0501	Side Panel - Left	1
	RXG0501	Side Panel—Left (SN 10600 +)	1
67	RX0201-80	Frame Weldment - RXT-080	1
67	RX0201-88	Frame Weldment - RXT-088	
67	RX0201-96	Frame Weldment - RXT-096	
68	OR3555	O-Ring - 35x5.5	1
69	B30307	Bearing 30307	2
70	SRI90000	Snap Ring Int. 90mm	1

Tar River Equipment

RXT-080 - RXT-088 - RXT-096 (Version 3)

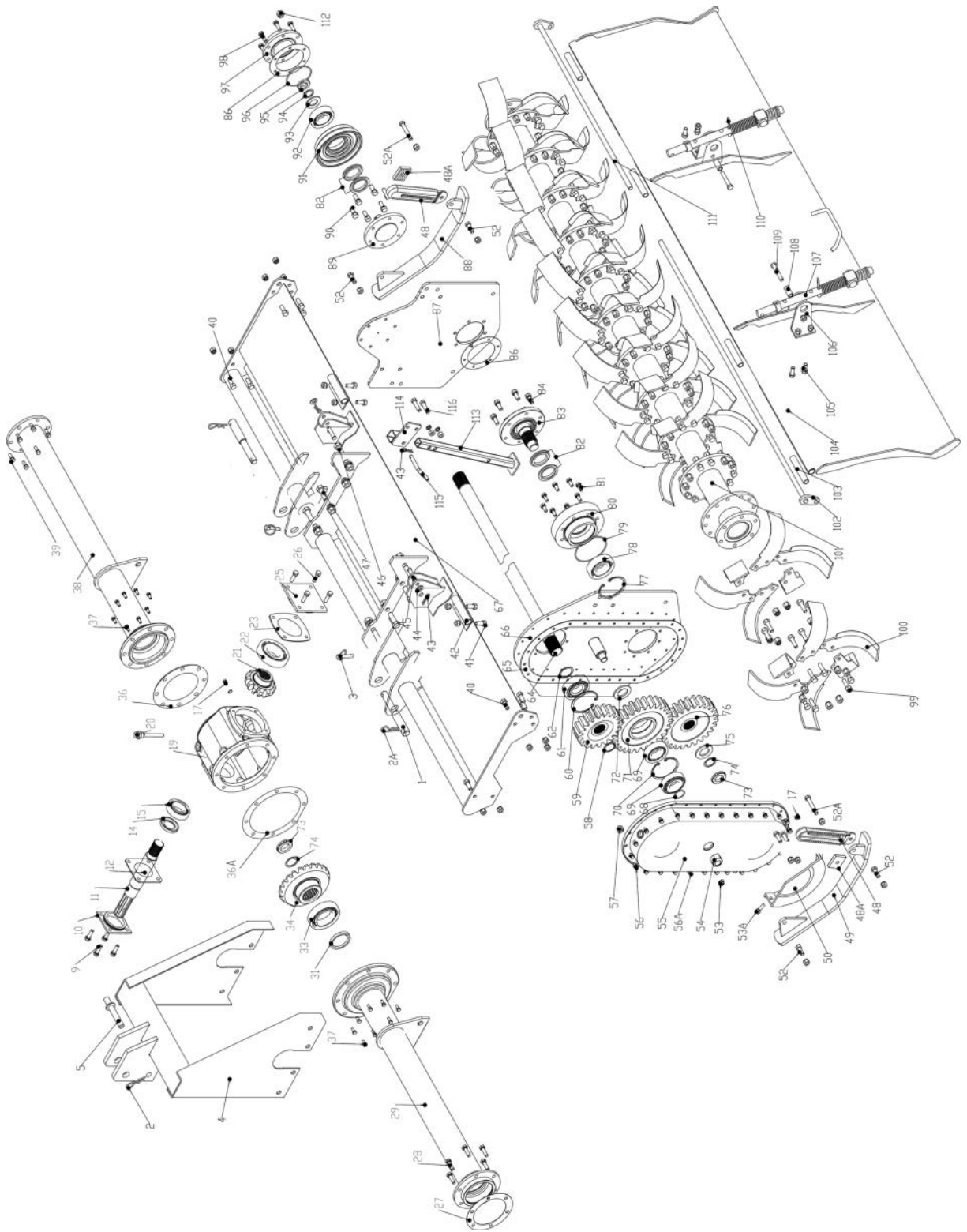

Tar River Equipment

RXT-080 - RXT-088 - RXT-096 (Version 3)

POS.	Part #	Description	Qty
71	RX0507	Idler Gear	1
72	RX0509	Spacer	1
73	T810-1998	Nut 36*1.5	2
74	SRE3500	Snap Ring Ext. 35mm	2
75	FW3600	Flat Washer 36mm	1
76	RX0508	Bottom Gear	1
77	SRI100	Snap Ring Int. 100mm	1
78	B6309	Bearing - 6309	1
79	OR122355	O-Ring - - 122x 3.55	1
80	RX0402	Bearing Support - Left Side	1
81	BM101525	Bolt 10 x 1.5 x 25	8
82	OS76535085	Float Oil Seal-76 x 53.5 x 8.5	2
83	RX0401	Rotor Support shaft - Left side	1
84	BM1217530	Bolt - 12 x 1.75 x 30	6
85	RX0204	Protector - Right Side	1
86	RX0406	Gasket - Rotor	2
87	RX0201	Side Panel - Right	1
	RXGU0201	Side Panel—Right (SN 10600+)	
88	RX0602	Skid Weldment - Right	1
	RXG0602	Skid Weldment—Right Right (SN 10600+))	
89	RX0403	Rotor Support shaft - Right side	1
90	BM101530	Bolt 10 x 1..5 x 30	6
91	RX0404	Bearing Support	1
92	B6308	Bearing - 6308	1
93	FW3000	Flat Washer 30mm	1
94	SRE30000	Snap Ring Ext. 30mm	1
95	SNM30150	Spanner Nut 30x 1.5	1
96	OR925355	O Ring - 92.5 x 3.55	1
97	RX0405	End Cap - Rotor Right side	1
98	BM101535	Bolt 10 x 1.5 x 35	6
99	BM141540	Bolt - 14 x 1.5 x 40	-
	NM140001	Nut 14mm—Fine Thread	-
100	RX0407L	Blade - Left	30-33-36
100	RX0407R	Blade - Right	30-33-36
100	RXU0407L	Blade - Left (SN 10600+)	28-30-33
100	RXU0407R	Blade - Right (SN 10600+)	28-30-33
101	RX0401-80	Rotor -RXT-080	1
101	RX0401-88	Rotor -RXT-088	1
101	RX0401-96	Rotor -RXT-096	1
101	RXU0401-80	Rotor -RXT-080 (SN 10600+)	1
101	RX0U401-88	Rotor -RXT-088 (SN 10600+)	1
101	RX04U01-96	Rotor -RXT-096 (SN 10600+)	1

Tar River Equipment

RXT-080 - RXT-088 - RXT-096 (Version 3)

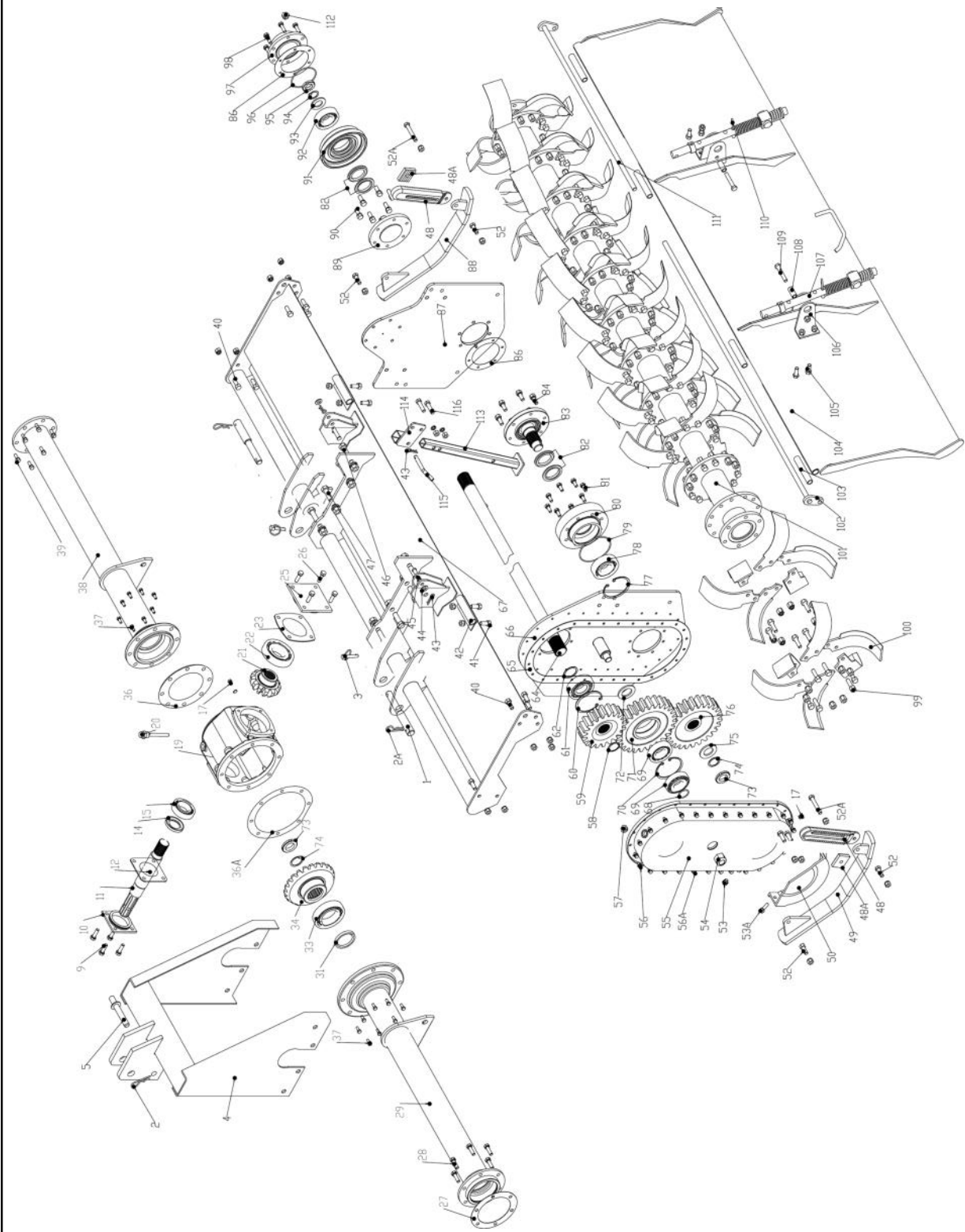

Tar River Equipment

RXT-080 - RXT-088 - RXT-096 (Version 3)

POS.	Part #	Description	Qty
102	RX0701L-80	Rod - Tailgate RXT-080 Left	1
102	RX0701L-88	Rod - Tailgate RXT-088 Left	1
102	RX0701L-96	Rod - Tailgate RXT-096 Left	1
103	RX0708	Rod Tube - Nylon	1
104	RX0702-80	Tailgate RXT-080	1
104	RX0702-88	Tailgate RXT-088	1
104	RX0702-96	Tailgate RXT-096	1
105	BM1217525	Bolt- 12 x 1.75 x 25	4
106	RX0702	Bracket - Tailgate Spring	2
107	RX0703	Rod - Tailgate Spring	2
108	RX0701	Bushing - Tailgate	2
109	BM1217570	Bolt-12 x 1.75 x 70	2
110	RX0707	Spring - Tailgate	4
111	RX0701R-80	Rod - Tailgate RXT-080 Right	1
111	RX0701R-88	Rod - Tailgate RXT-088 Right	1
111	RX0701R-96	Rod - Tailgate RXT-096 Right	1
113	RX0801	Stand	1
114	RX0802	Bracket—Stand	1
115	YT10660501	Pin	1
116	BM1217530	Bolt 12 x 1.75 x 30	2
	147125	Complete PTO - Series 60 - 200mm Slip Clutch	
	180-510-60 WE970-4160	Friction Disc - 6 1/3"OD	

Tar River Equipment
BXV-075 - BXV-085 - BXV-094 - BXV-104

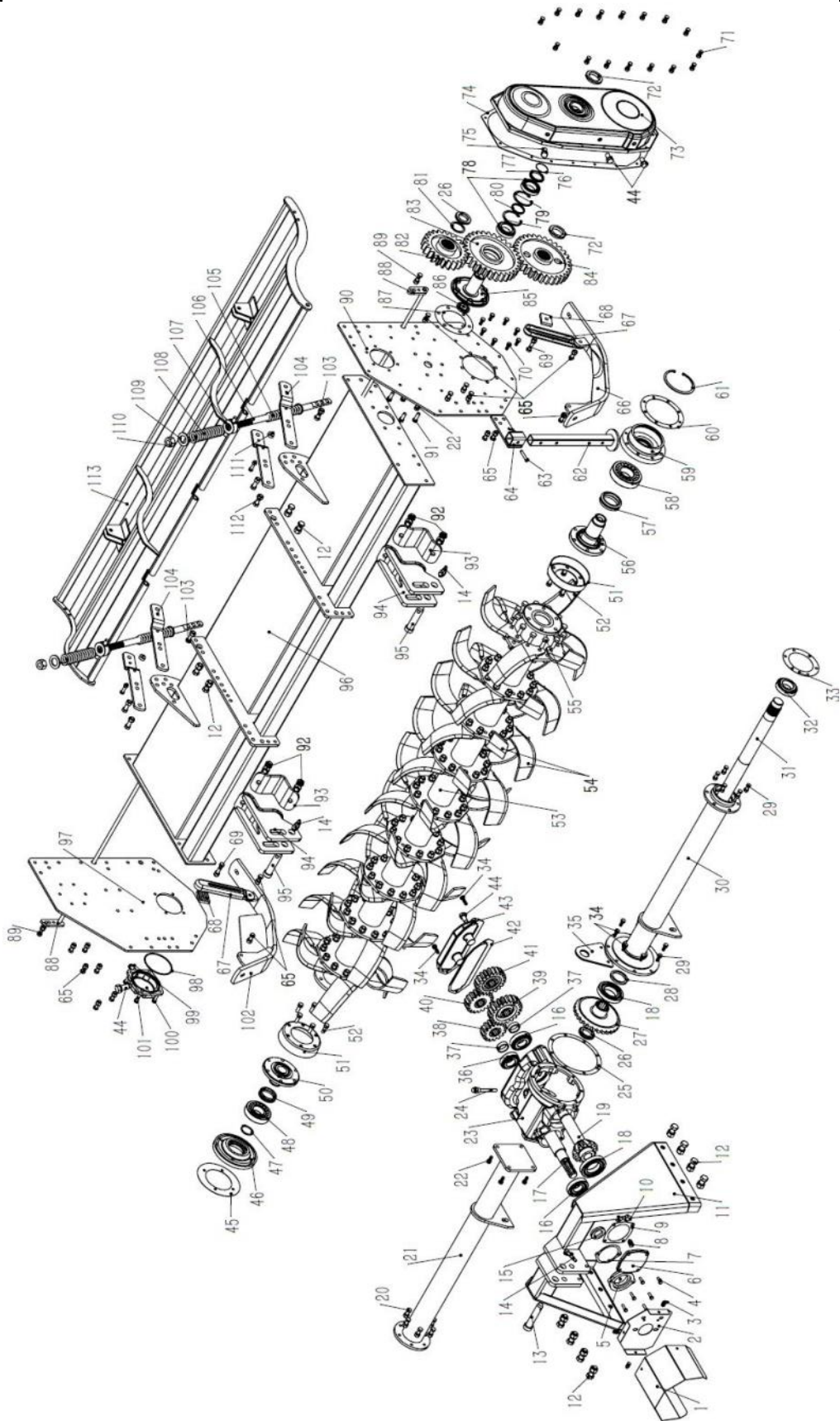

Tar River Equipment
BXV-075 - BXV-085 - BXV-094 - BXV-104

POS.	Part #	Description	Qty
1	BV0317	PTO shield	1
2	BV0321	PTO shield support	1
3	BM812516	Bolt 8x1.25x16	3
4	BM1012530	Bolt 10x1.25x30	6
5	BV0320	Bearing support	1
6	BV0315	Gearbox cap	1
7	BV0318	Gasket - Input Shaft 107x91x1	1
8	BM1012520	Bolt 10x1.25x20	1
9	BV0314	Gasket Bearing Cover—150x112x1	1
10	BV0408	Spacer— Rotor Support Right 63x50x4	1
11	BV0101	A Frame	1
12	BM161540	Bolt 16x1.5x40	12
13	BV0103	Top Hitch Pin	1
14	SB100756	Lynch Pin 10mm	3
15	OS406210	Oil Seal40x62x10	1
16	B30308JR	Bearing 30308JR	2
17	BV0319	Input Shaft	1
18	B30212JR	Bearing 30212JR	2
19	BV0316	Pinion Shaft	1
20	BM1012535	Bolt 10x1.25x35	6
21	BV0301-75	Gearbox Support Tube BXV-076	-
	BV0301-85	Gearbox Support Tube BXV-086	-
	BV0301-94	Gearbox Support Tube BXV-094	-
	BV0301-104	Gearbox Support Tube BXV-104	-
22	BM1212530	Bolt 12x1.25x30	5
23	BV0313	Housing -Gearbox	1
24	BV0323	Dip Stick	1
25	BV0309	Gasket - Center Gearbox Left Side 240x206x0.5	1
26	NM4515	Nut 45x1.5	2
27	BV0324	Ring Gear	1
28	OS607508	Oil Seal 60x75x8	1
29	BM1012530	10X1.25X30	12
30	BV0310-75	Gearbox Shaft Tube Housing - BXV-076	-
	BV0310-85	Gearbox Shaft Tube Housing - BXV-086	-
	BV0310-94	Gearbox Shaft Tube Housing - BXV-094	-
	BV0310-104	Gearbox Shaft Tube Housing - BXV-104	-
31	BV0311-75	Drive Shaft -BXV-076	-
	BV0311-85	Drive Shaft -BXV-086	-
	BV0311-94	Drive Shaft -BXV-094	-
	BV0311-104	Drive Shaft -BXV-104	-
32	B32210JR	Bearing 32210JR	1
33	BV0312	Gasket Drive Shaft—162x111x1	1

Tar River Equipment
BXV-075 - BXV-085 - BXV-094 - BXV-104

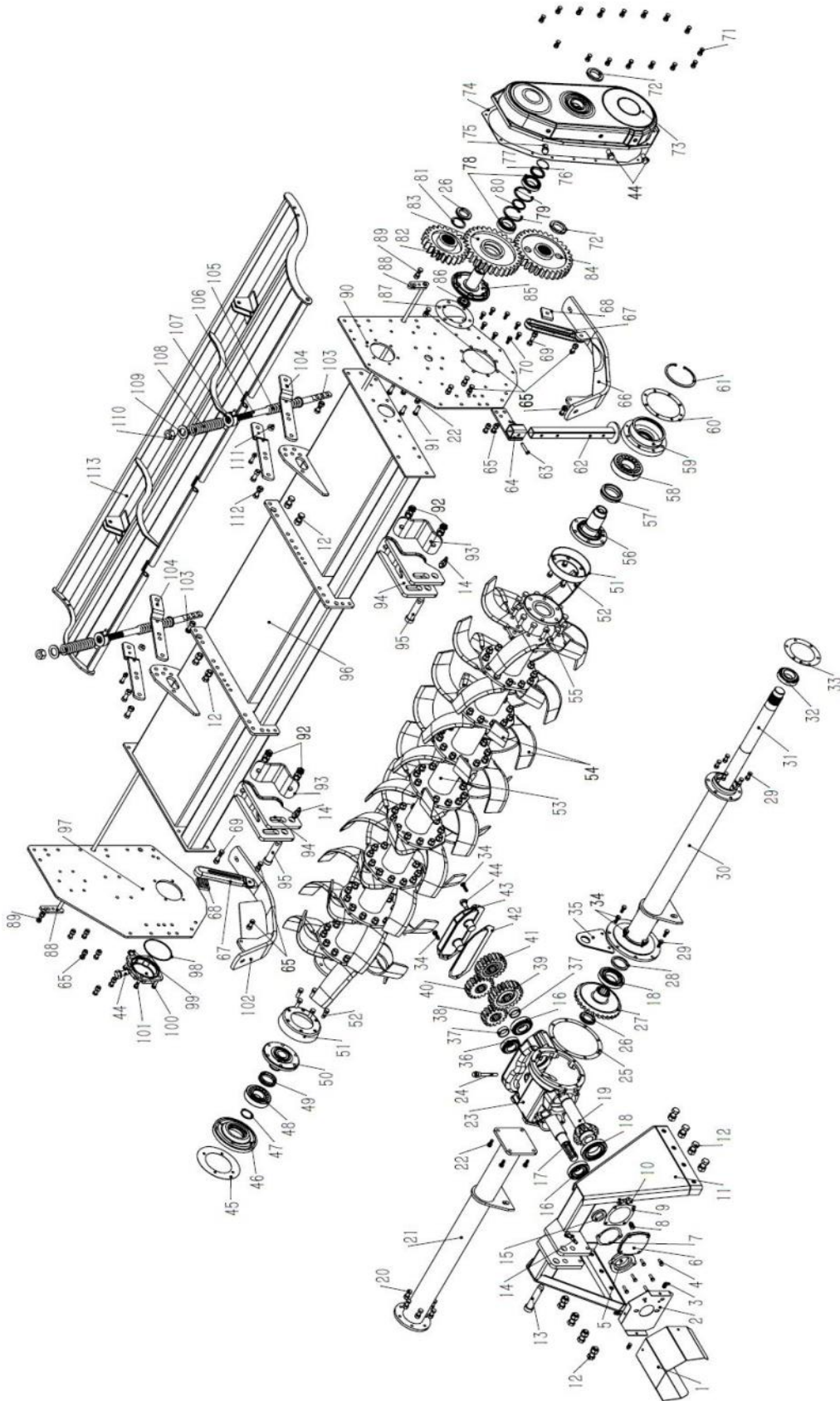

Tar River Equipment
BXV-075 - BXV-085 - BXV-094 - BXV-104

POS.	Part #	Description	Qty
34	BM1012535	Bolt 10x1.25x35	4
35	BV0322	Gearbox Lift Bracket	1
36	B32208JR	Bearing 32208JR	1
37	BV0308	Spacer—Exchange Gear 48x40x15	2
38	BV0304	Exchange Gear Z16	1
39	BV0307	Exchange Gear Z22	1
40	BV0303	Exchange Gear Z18	1
41	BV0306	Exchange Gear Z20	1
42	BV0302	Gasket - Rear Cover	1
43	BV0305	Rear Cover	1
44	OP1615000	Oil Plug 16 x1.5	4
45	BV0407	Gasket - Right Rotor 192x118x1	1
46	BV0406	Support - Bearing Right Rotor	1
47	SRE5000	Snap Ring 50 - External	1
48	B20310C	Bearing 20310C	1
49	OSFH0610	FH0610 Floating Seal	1
50	BV0405	Rotor Support Shaft - Right	
51	BV0403	Rotor Shield	2
52	BM1212535	Bolt 12x1.25x35	12
53	BV0401 - 75	Rotor Shaft - BXV-075	1
	BV0401 - 85	Rotor Shaft - BXV-085	
	BV0401 - 94	Rotor Shaft - BXV-094	
	BV0401 - 104	Rotor Shaft - BXV-104	
54	BV0210R	Tiller Tine - Right	24-27-30-33
	BV0210L	Tiller Tine - Left	24-27-30-33
55	BM141540	Bolt 14x1.5x40 Fine Thread	96-108-120-132
	LW14000	Lock Washer 14mm	96-108-120-132
	NM140001	Nut 14mm Fine Thread	96-108-120-132
56	BV0402	Rotor Support Shaft - Left	1
57	OSH0720A	FH0720A Floating Seal	1
58	B213120	Bearing 213120	1
59	BV0401	Bearing support	1
60	BV0511	Gasket—Left Rotor 194x150x1	1
61	SRI130	Snap Ring 130 - Internal	1
62	BV0702	Stand	1
63	BV0703	Lynch Pin 10x55	1
64	BV0701	Bracket - Stand	1
65	BM1212535	Bolt 12x1.25x35	16
66	BV0902	Skid Weldment -left	1

Tar River Equipment
BXV-075 - BXV-085 - BXV-094 - BXV-104

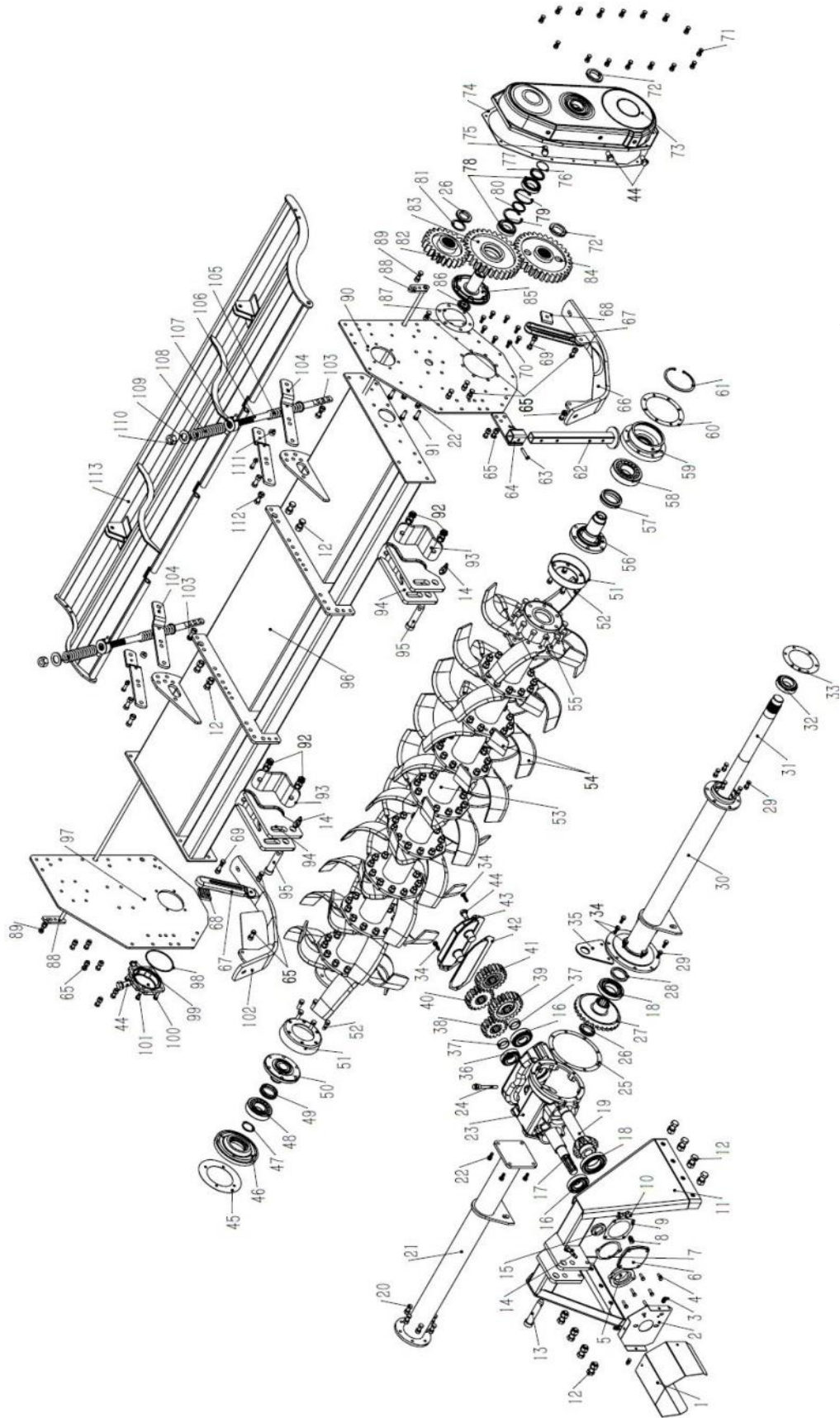

Tar River Equipment
BXV-075 - BXV-085 - BXV-094 - BXV-104

POS.	Part #	Description	Qty
67	BV0801	Skid Adjustment Bracket	2
68	BV0802	Skid Adjustment Stop	2
69	BM1212560	Bolt 12x1.25x60	2
70	BM1012525	Bolt 10x1.25x25	8
71	BM1012525	Bolt 10x1.25x25	14
72	SNM50150	Spanner Nut 50X1.5	2
73	BV0500	Gear Cover	1
74	BV0507	Gasket - Gear Cover	1
75	OP1615V	Breather Cap M16 x 1.5	1
76	OR5018	O Ring 50 x 1.8	1
77	BV0503	Spacer—Idler Gear 63.5x50x6.5	1
78	B32010JR	Bearing 32010JR	
79	SRI80000	Snap Ring 80 - Internal	2
80	BV0505	Gasket—Center Gear 57x50x5	1
81	BV0506	Spacer—Top Gear 63x50 x2	1
82	BV0508	Gear - Top - Z-23	1
83	BV0502	Gear - Idler - Z-31	1
84	BV0501	Gear - Bottom - Z-31	1
85	BV0510	Idler Gear Hub	1
86	LN3515	Lock Nut 35 x 1.5	1
87	BV0509	Gasket - Idler Gear hub 170x140x1	1
88	BV0605-75	Rod - Tail Gate - BXV-075	2
	BV0605-85	Rod - Tail Gate - BXV-085	
	BV0605-94	Rod - Tail Gate - BXV-094	
	BV0605-104	Rod - Tail Gate - BXV-0104	
89	BM1212545	Bolt 12x1.25x45	2
90	BV0506	Side Board-Left	1
91	BM1212540	Bolt 12x1.25x40	4
92	BM181550	Bolt 18x1.5x50	4
93	BV0204	Hitch Block Support	2
94	BV0203	Lower Hitch Block	2
95	BV0205	Lower Hitch Pin	2
96	BV0201-75	Main Frame - BXV-075	1
	BV0201-85	Main Frame - BXV-085	
	BV0201-94	Main Frame - BXV-094	
	BV0201-104	Main Frame - BXV-104	
97	BV0202	Side Board - Right	1
98	OR118355	Oil Ring 118 x 3.55	1
99	OP12125	Oil Plug 12 x 1.25	1

Tar River Equipment

BXV-075 - BXV-085 - BXV-094 - BXV-104

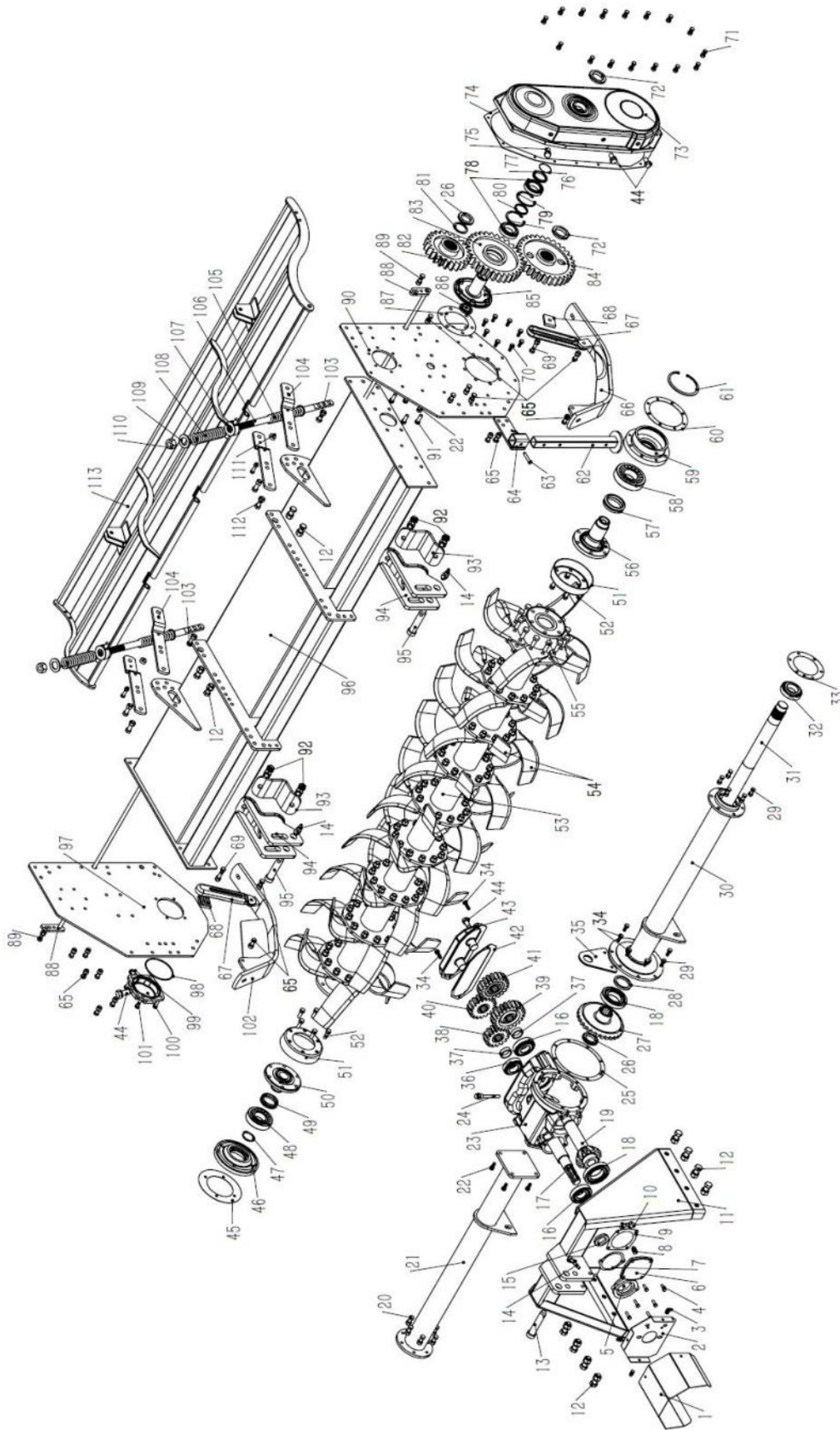

Tar River Equipment
BXV-075 - BXV-085 - BXV-094 - BXV-104

POS.	Part #	Description	Qty
100	BV0409	Rotor Cap	1
101	BM1212540	Bolt 12x1.25x40	4
102	BV0901	Skid Weldment -Right	1
103	BM1012545	Bolt 10x1.25x45	2
104	BV0603	Bracket - Tailgate Spring	4
105	BV0602	Lower Spring - Tailgate 184mm	2
106	BV0601	Rod - Tailgate	2
107	BV0606	Spring Bushing	2
108	BV0602	Upper Spring - Tailgate 175mm	2
109	FW24000	Washer	2
110	LNM24000	Lock Nut 24 mm	2
111	BV0604	Spacer—Tailgate Brackets 26x10.5x10	2
112	BM141545	Bolt 14x1.5x45	6
113	BV0602 -075	Tailgate BXV-075	1
	BV0602 -085	Tailgate BXV-085	
	BV0602 -094	Tailgate BXV-094	
	BV0602 -104	Tailgate BXV-104	
	147127	Complete PTO - Series 80 - 200mm Slip Clutch	
	180-510-60 WE970-4160	Friction Disc - 6 1/3"OD	

Tar River Equipment

CXT

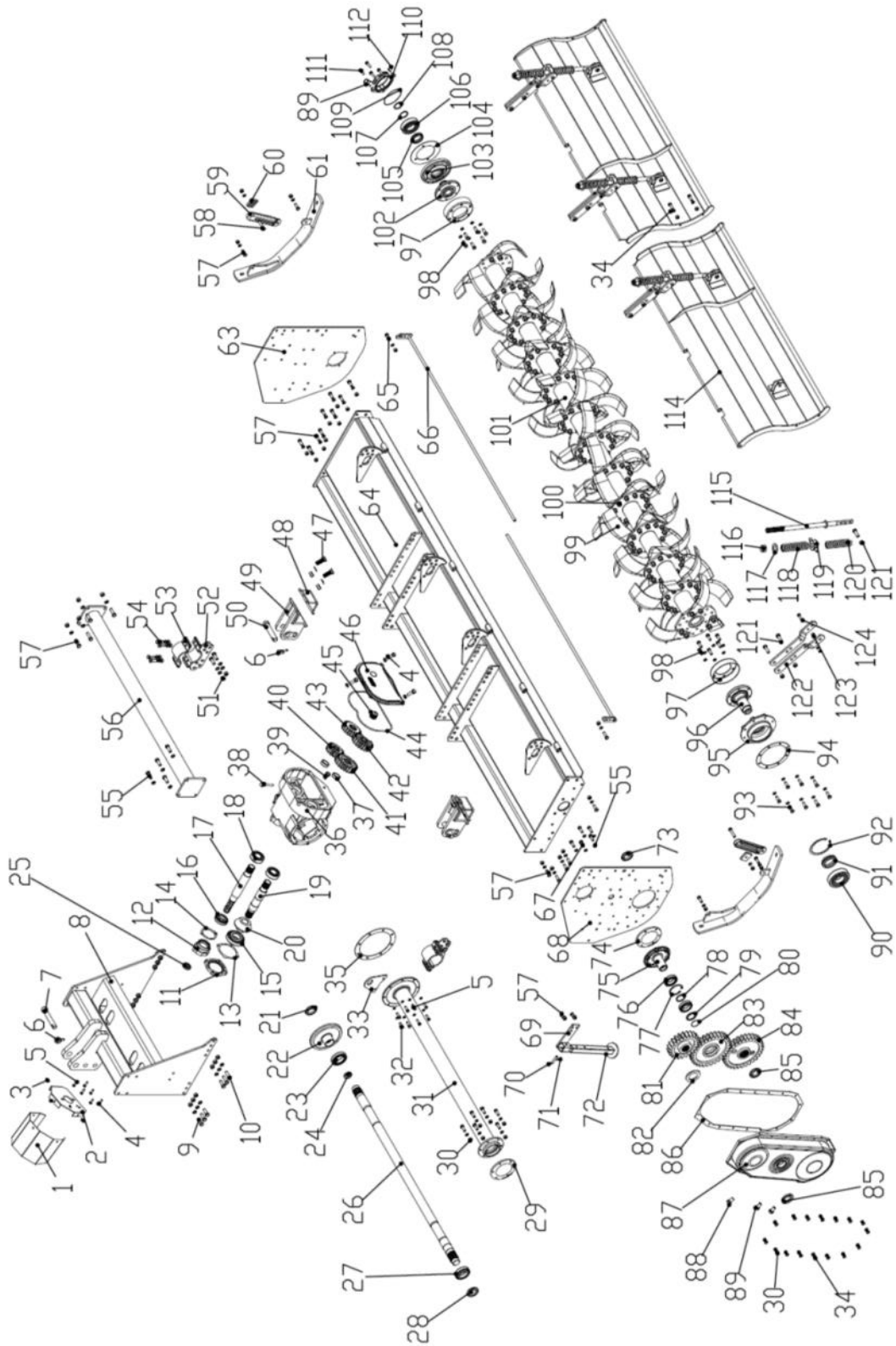

Tar River Equipment

CXT

POS.	Part #	Description	Qty
1	BV0317	PTO shield	1
2	BV0321	PTO shield support	1
3	BM812516	Bolt 8x1.25x16	3
4	BM1012535	Bolt 10x1.25x35	7
5	BM1012535	Bolt 10x1.25x35	4
6	SB100756	Lynch Pin 10mm	3
7	BV0103	Top Hitch Pin	1
8	CX0101	A Frame	1
9	BM141540	Bolt 14x1.5x40	8
10	BM141545	Bolt 14x1.5x45	4
11	CX0315	Bearing Cap, Pinion Shaft	1
12	CX0320	Cap, Input Shaft	1
13	CX0314	Gasket - Pinion shaft	1
14	CX0318	Gasket - Input Shaft	1
15	B31310	Bearing 31310	1
16	B31208	Bearing 31208	1
17	CX0319	Input Shaft	1
18	B33208	Bearing 33208	2
19	CX0316	Pinion Shaft	1
20	CX0323	Pinion Gear	1
21	NM4515	Nut 45x1.5	1
22	CX0322	Ring Gear	1
23	B32012	Bearing 32012	1
24	OS60758	Oil Seal 60x75x8	1
25	OS406210	Oil Seal 40625x10	1
26	CX0311-076	Drive Shaft CXT-076	1
	CX0311-086	Drive Shaft CXT-086	1
	CX0311-095	Drive Shaft CXT-095	1
	CX0311-104	Drive Shaft CXT-104	1
	CX0311-112	Drive Shaft CXT-112	1
	CX0311-121	Drive Shaft CXT-121	1
27	B32210	Bearing 32210	1
28	NM4515	Nut 45x1.5	1
29	BV0312	Gasket - Drive Tube Outer	1
30	BM1012530	Bolt 10x1.25x30	20
31	CX0310-076	Drive Shaft Tube Housing - CXT-076	1
	CX0310-086	Drive Shaft Tube Housing - CXT-086	1
	CX0310-095	Drive Shaft Tube Housing - CXT-095	1
	CX0310-104	Drive Shaft Tube Housing - CXT-104	1
	CX0310-112	Drive Shaft Tube Housing - CXT-112	1
	CX0310-121	Drive Shaft Tube Housing - CXT-121	1

Tar River Equipment

CXT

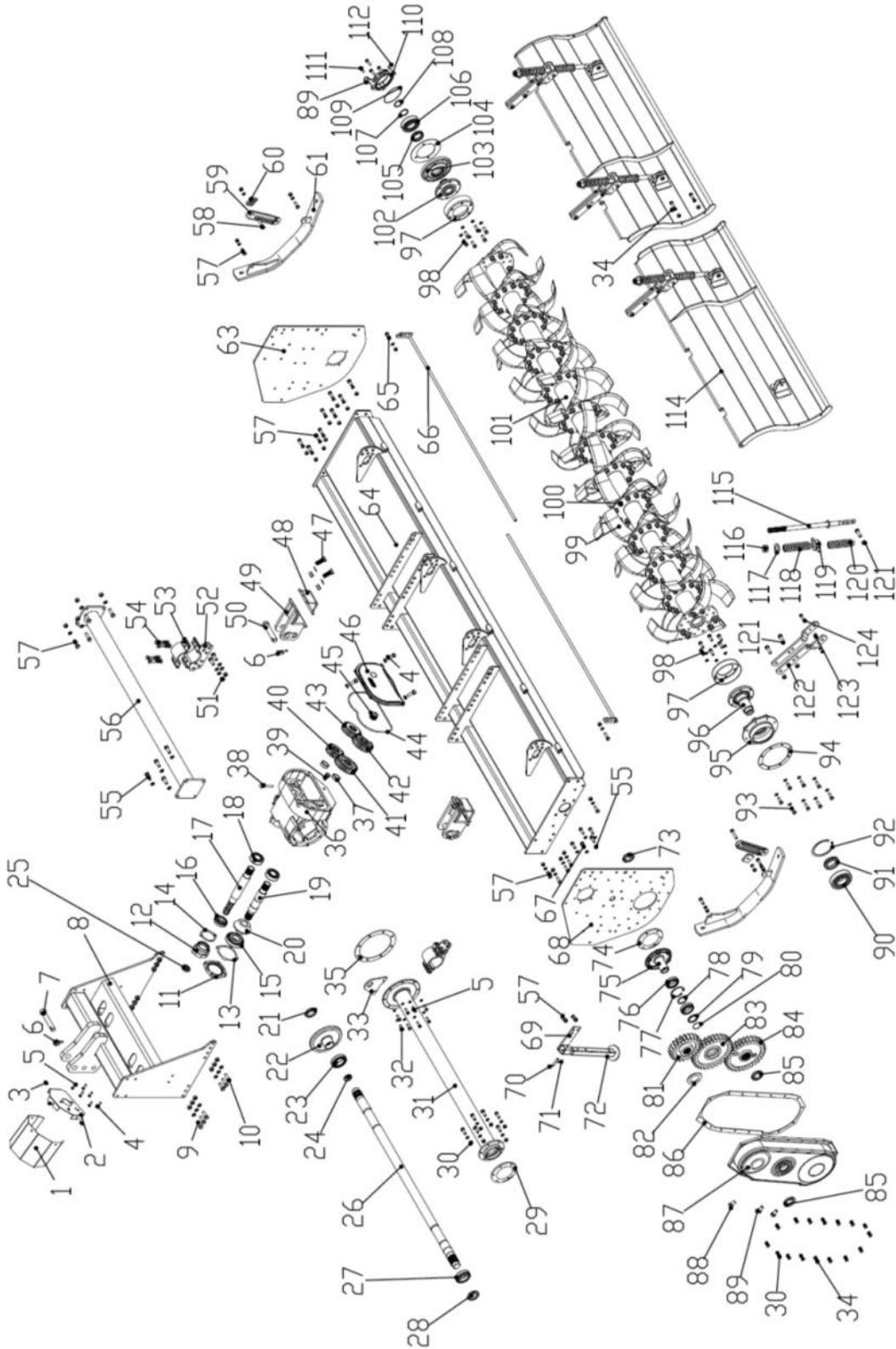

Tar River Equipment

CXT

POS.	Part #	Description	Qty
32	BM1012530	Bolt 10x1.25x30	6
33	BV0322	Gearbox Lift Bracket	1
34	BM1012535	Bolt 10x1.25x35	4
35	CX0309	Gasket- Drive Tube - Inner	1
36	CX0313	Gearbox Housing	1
37	CX0308	Spacer—Exchange Gear	2
38	YT10660303000	Dipstick	1
39	OP1415000	Oil Plug 14x1.5	1
40	CX0304	Exchange Gear Z17	1
41	CX0303	Exchange Gear Z23	1
42	CX0307	Exchange Gear Z21	1
43	CX0306	Exchange Gear Z19	1
44	CX0302	Gasket Rear Cover	1
45	CX0312	Gear Shaft	1
46	CX0305	Gearbox Cover	1
47	BM151550	Bolt 18 x 1.5 x 50	4
48	BX0207	Hitch Block Support	2
49	CX0205	Htich Block	2
50	CX0204	Lower Hitch Pin - Cat. 2	2
51	BM1412540	Bolt 14x1.50x40	4
52	CX0203	Tube Support - Lower	2
53	CX0202	Tube Support - Upper	2
54	BM1212540	Bolt 12x1.25x40	8
55	BM1212530	Bolt 12x1.25x30	5
56	CX0301-076	Gearbox Support Tube - CXT-076	1
	CX0301-086	Gearbox Support Tube - CXT-086	1
	CX0301-095	Gearbox Support Tube - CXT-095	1
	CX0301-104	Gearbox Support Tube - CXT-104	1
	CX0301-110	Gearbox Support Tube - CXT-112	1
	CX0301-121	Gearbox Support Tube - CXT-121	1
57	BM1212535	Bolt 12x1.25x35	24
58	BM1212560	Bolt 12x1.25x60	2
59	BX0802	Skid Adjustment Stop	2
60	BX0801	Skid Adjustment Bracket	2
61	BV0901	Skid Weldment - Right	1
62	BV0801	Skid Weldment - Left	1
63	CX0201	Side Board-Right	1
64	CX300-076	Main Frame - CXT-076	1
	CX300-086	Main Frame - CXT-086	1
	CX300-095	Main Frame - CXT-095	1
	CX300-104	Main Frame - CXT-104	1
	CX300-112	Main Frame - CXT-112	1
	CX300-121	Main Frame - CXT-121	1
65	BM1212545	Bolt 12x1.25x45	2

Tar River Equipment

CXT

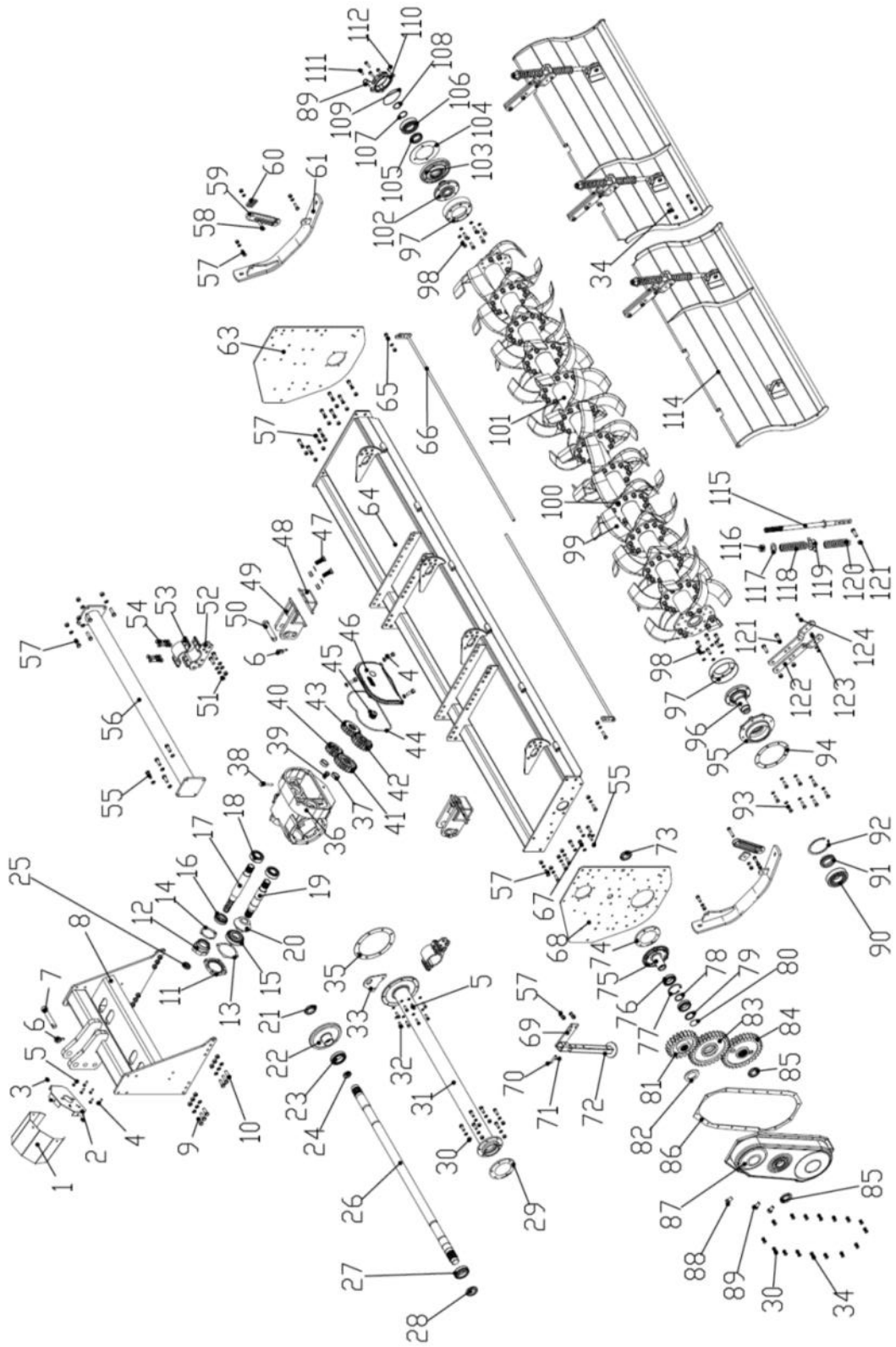

Tar River Equipment

CXT

POS.	Part #	Description	Qty
66	CX0603-076	Rod Tailgate - CXT-076	2
	CX0603-086	Rod Tailgate - CXT-086	2
	CX0603-095	Rod Tailgate - CXT-095	2
	CX0603-104	Rod Tailgate - CXT-104	2
	CX0603-112	Rod Tailgate - CXT-112	2
	CX0603-121	Rod Tailgate - CXT-121	2
67	BM1212540	Bolt 12x1.25x40	4
68	BV0506	Side Board-Left	1
69	BV0701	Bracket - Stand	1
70	BV0703	Lynch Pin 10x55	1
71	RC3000	R Pin 3mm	1
72	BV0702	Stand	1
73	NM3515	Nut 35x1.5	1
74	BV0509	Gasket - Idler Gear hub 170x140x1	1
75	BV0510	Idler Gear Hub	1
76	B32010	Bearing 32010	2
77	SRI80000	Snap Ring 80 - Internal	2
78	BV0504	Spacer— 63x50 x2	1
79	BV0503	Spacer—Idler Gear 63.5x50x6.5	1
80	OR5018	O Ring 50x1.8	1
81	BV0505	Gear - Top - Z-23	1
82	BV0506	Spacer—Top Gear 63x50 x2	1
83	BV0502	Gear - Idler - Z-31	1
84	BV0501	Gear - Bottom - Z-31	1
85	SNM50150	Spanner Nut 50X1.5	2
86	BV0507	Gasket - Gear Cover	1
87	BV0500	Gear Cover	1
88	OP1615V	Breather Cap M16 x 1.5	1
89	OP1615000	Oil Plug 16 x1.5	3
90	B6312	Bearing 6312	1
91	OSHF0720A	Oil Seal HF0720A	1
92	SRI130	Snap Ring 130 - Internal	1
93	BM1012525	Bolt 10x1.25x25	8
94	CX0511	Gasket—Left Rotor	1
95	CX0401	Bearing support	1
96	BV0402	Rotor Support Shaft - Left	1
97	BV0403	Rotor Shield	2
98	BM1212535	Bolt 12x1.25x35	12
99	BV0210R	Tiller Tine - Right	-
	BV0210L	Tiller Tine - Left	-
100	BM141540	Bolt 14x1.5x40 Fine Thread	-

Tar River Equipment

CXT

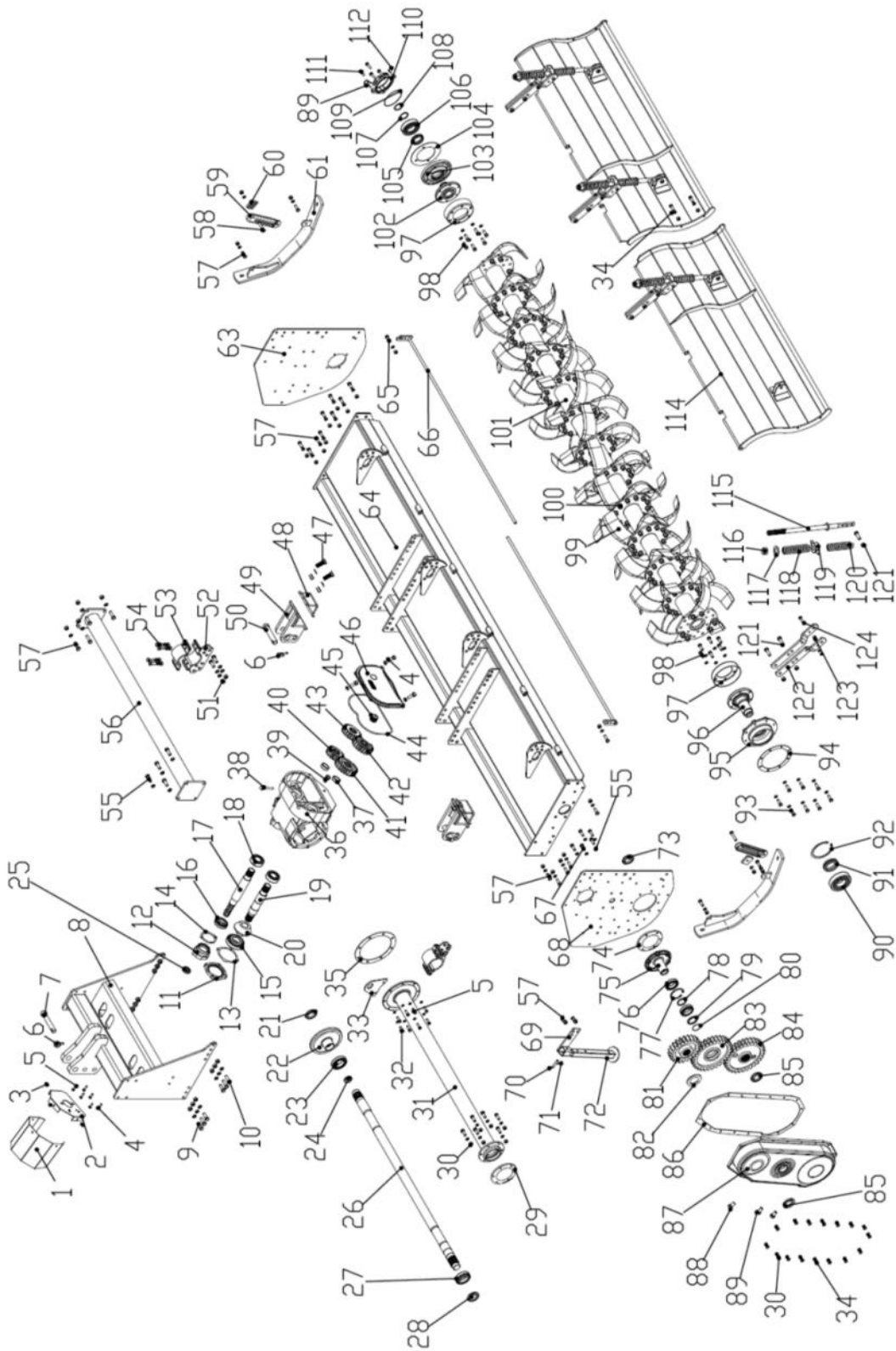

Tar River Equipment

CXT

POS.	Part #	Description	Qty
101	CX0401-076	Rotor Shaft - CXT-076	1
	CX0401-086	Rotor Shaft - CXT-086	1
	CX0401-095	Rotor Shaft - CXT-095	1
	CX0401-104	Rotor Shaft - CXT-104	1
	CX0401-112	Rotor Shaft - CXT-112	1
101	CX0401-121	Rotor Shaft - CXT-121	1
102	BV0405	Rotor Support Shaft - Right	1
103	BV0406	Support - Bearing Right Rotor	1
104	BV0407	Gasket - Right Rotor 192x118x1	1
105	OSHP0610	Oil Seal HP0610	1
106	6310	Bearing	1
107	BV0408	Spacer - Rotor Support Right 63x50x4	1
108	SRE5000	Snap Ring 50 - External	1
109	OR118355	Oil Ring 118 x 3.55	1
110	BV0409	Rotor Cap	1
111	BM1212540	Bolt 12x1.25x40	4
112	OP12125	Oil Plug 12mm x 1.25	1
114	CX0601-076R	Tailgate-Right - CXT-076	1
	CX0601-076L	Tailgate-Left - CXT-076	1
	CX0601-086R	Tailgate-Right - CXT-086	1
	CX0601-086L	Tailgate-Left - CXT-086	1
	CX0601-095R	Tailgate-Right - CXT-095	1
	CX0601-095L	Tailgate-Left - CXT-095	1
	CX0601-104R	Tailgate-Right - CXT-104	1
	CX0601-104L	Tailgate-Left - CXT-104	1
	CX0601-112R	Tailgate-Right - CXT-112	1
	CX0601-112L	Tailgate-Left - CXT-112	1
	CX0601-121R	Tailgate-Right - CXT-121	1
	CX0601-121L	Tailgate-Left - CXT-121	1
115	BV0601	Rod - Tailgate	4
116	LN24000	Lock Nut 24 mm	4
117	FW24000	Washer	4
118	BV0601	Upper Spring - Tailgate 175mm	4
119	BV0606	Spring Bushing	4
120	BV0602	Lower Spring - Tailgate 184mm	4
121	BM141545	Bolt 14x1.5x45	12
122	BV0603	Bracket - Tailgate Spring	8
123	BV0604	Spacer—Tailgate Brackets 26x10.5x10	4
124	BM1012545	Bolt 10x1.25x45	4
	147127	Complete PTO - Series 80 - 200mm Slip Clutch	
	180-510-60 WE970-4160	Friction Disc - 6 1/3"OD	

PTO Shaft

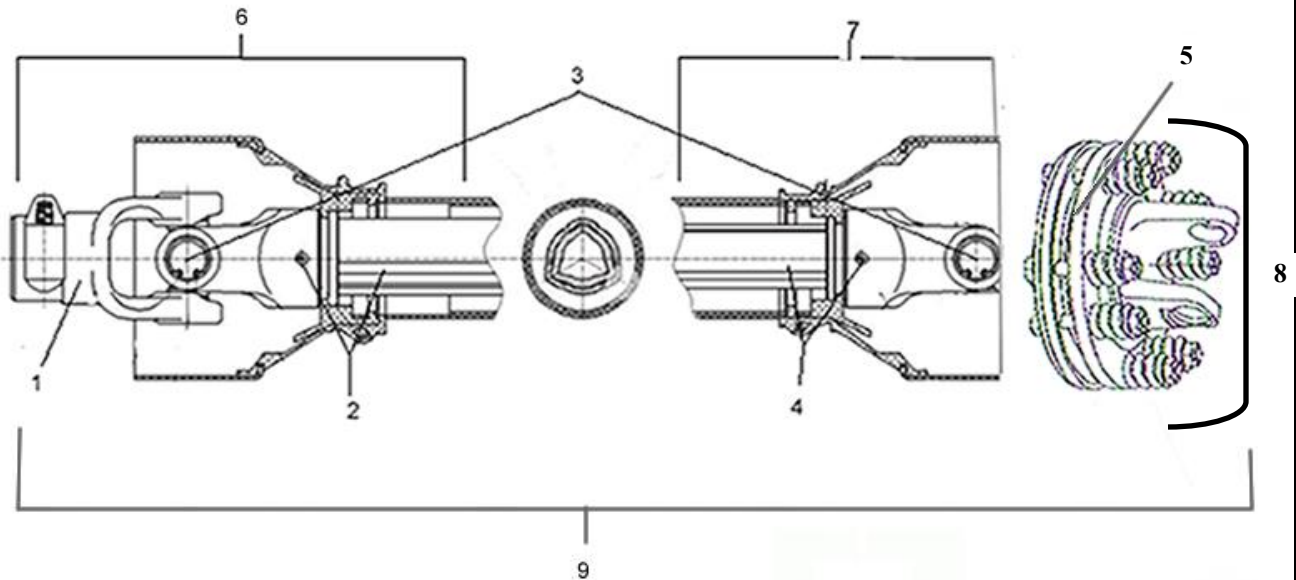

Pos.	Part #	Description	Qty
1	DP1075-60	PTO Yoke - Series 60	1
	DP1075-80	PTO Yoke—Series 80	
2	DP1079-60	Female Yoke and Tube (tractor end) - Series 60	1
	DP1079-80	Female Yoke and Tube (tractor end) - Series 80	
3	DP1076-60	Cross and Bearings - Series 60	2
	DP1076-80	Cross and Bearings - Series 80	
4	DP1078-60	Male Yoke and Tube (implement end) - Series 60	1
	DP1078-80	Male Yoke and Tube (implement end) - Series 80	
5	180-510-60	Friction Disc - 6 1/3OD	4
6	DP1074F-60	Complete Female End PTO Shielding (tractor end) - Series 60	1
	DP1074F-80	Complete Female End PTO Shielding (tractor end) - Series 80	
7	DP1074M-60	Complete Male End PTO Shielding (implement end) - Series 60	1
	DP1074M-80	Complete Male End PTO Shielding (implement end) - Series 80	
8	DP1098-60	Slip Clutch Complete - 200 mm Clutch (4 disc) for Series 60	1
	DP1098-80	Slip Clutch Complete - 200 mm Clutch (4 disc) for Series 80	
9	147125	Complete PTO - Series 60 - 200mm Slip Clutch (RXT)	1
	147130	Complete PTO - Series 80 - 200mm Slip Clutch (BXV & CXT)	

MODEL MODIFICATIONS

MODEL	VERSION	SERIAL RANGE
RXT-080	1	Up to 161073
RXT-088	1	Up to 181092
RXT-096	1	Up to 171159
RXT-072	2	151235-151254
RXT-080	2	161074-161078
RXT-088	2	181093-181105
RXT-096	2	171160-171179
RXT-072	3	151255+
RXT-080	3	151259 +
RXT-088	3	181106 +
RXT-096	3	171180 +

NOTES

LIMITED WARRANTY

Tar River Equipment warrants to the original purchaser of any new piece of machinery from Tar River Equipment, purchased from an authorized Tar River Equipment dealer, that the equipment be free from defects in material and work-manship for a period of one (1) year for non-commercial, state, and municipalities' use, ninety (90) days for commercial use from date of retail sale. Warranty for rental purposes is thirty (30) days. The obligation of Tar River Equipment to the purchaser under this warranty is limited to the repair or replacement of defective parts.

A four (4) year extended **Gearbox Limited Warranty** is provided for YCT, RXT AND CXT models at the end of the standard one (1) year warranty period. This warranty is not provided for commercial or rental uses. The extended warranty provides for the replacement of parts only. Not covered are oil seals or any damages to the gearbox due to lack of lubrications.

Replacement or repair parts installed in the equipment covered by this limited warranty are warranted for ninety (90) days from the date of purchase of such part or to the expiration of the applicable new equipment warranty period, whichever occurs later. Warranted parts shall be provided at no cost to the user at an authorized Tar River Equipment dealer during regular working hours. Tar River Equipment reserves the right to inspect any equipment or parts which are claimed to have been defective in material or work-manship.

This limited warranty does not apply to and excludes wear items such as shear pins, tires, tubes knives, blades or other wear items. Oil or grease is not covered by this warranty.

All obligations of Tar River Equipment under this limited warranty shall be terminated if:

- Proper service is not preformed on the machine**
- The machine is modified or altered in any way.**
- The machine is being used or has been used for purposes other than those for which the machine was intended.**

DISCLAIMER OF IMPLIED WARRANTIES & CONSEQUENTIAL DAMAGES

Tar River Equipment obligation under this limited warranty, to the extent allowed by law, is in lieu of all warranties, implied or expressed, including implied warranties of merchantability and fitness for a particular purpose and any liability for incidental and consequential damages with respect to the sale or use of the items warranted. Such incidental and consequential damages shall include but not be limited to: transportation charges other than normal freight charges; cost of installation other than cost approved by Tar River Re-sources Equipment; duty; taxes; charges for normal service or adjustment; loss of crops or any other loss of income; rental of substitute equipment, expenses due to loss, damage, detention or delay in the delivery.