



TXG YCT YCT-R

Rotary Tillers

Operator's Manual



TABLE OF CONTENTS

INTRODUCTION	2
SAFETY.....	2
SAFETY SIGNAL WORDS	3
GENERAL SAFETY GUIDELINES	3
SAFETY DECAL CARE.....	4
BEFORE OPERATION.....	4
DURING OPERATION	5
HIGHWAY AND TRANSPORT OPERATIONS	6
OPERATION	8
FOLLOWING OPERATION.....	9
PREMORMING MAINTENANCE.....	9
MAINTENANCE	10
PARTS BREAKDOWN - YCT.	11-14
PARTS BREAKDOWN - TXG..	15-18
PARTS BREAKDOWN - YCT-R FRONT SHIELDING	19
PTO BREAKDOWN	20
LIMITED WARRANTY.....	21

PTO SHAFTS:

TXG - All sizes	Series 40 (slip Clutch 150mm)
YCT- 60-66-74	Series 40 (slip Clutch 180mm)
YCT-082 (EARLY)	Series 60 (slip Clutch 180mm)
YCT-082 (LATE)	Series 40 (slip Clutch 180MM)
RXT - All Sizes	Series 60 (slip Clutch 200mm)

INTRODUCTION

Thank you for purchasing your Tar River Equipment Tiller. Your rotary tiller is design to be used on 540 rpm tractors. It is important to properly maintain and keep in place all safety guards and shields that came with your tiller.

SAFETY

Read and understand this manual and all safety signs before operating and maintaining. Review the safety instructions and precautions annually.

TAKE NOTE! THIS SAFETY ALERT SYMBOL FOUND THROUGHOUT THIS MANUAL IS USED TO CALL YOUR ATTENTION TO INSTRUCTIONS INVOLVING YOUR PERSONAL SAFETY AND THE SAFETY OF OTHERS. FAILURE TO FOLLOW THESE INSTRUCTIONS CAN RESULT IN INJURY OR DEATH.



THIS SYMBOL MEANS

**ATTENTION!
BECOME ALERT!
YOUR SAFETY IS INVOLVED!**



SAFETY SIGNAL WORDS

Note the use of the signal words DANGER, WARNING and CAUTION with the safety messages. The appropriate signal word for each has been selected using the following guidelines:



DANGER: Indicates an imminently hazardous situation that, if not avoided, will result in death or serious injury. This signal word is to be limited to the most extreme situations typically for machine components which, for functional purposes, cannot be guarded.



WARNING: Indicates a potentially hazardous situation that, if not avoided, could result in death or serious injury, and includes hazards that are exposed when guards are removed. It may also be used to alert against unsafe practices.



CAUTION: Indicates a potentially hazardous situation that, if not avoided, may result in minor or moderate injury. It may also be used to alert against unsafe practices.



GENERAL SAFETY GUIDELINES

Safety of the operator is one of the main concerns in designing and developing a new piece of equipment. Designers and manufacturers build in as many safety features as possible. However, every year many accidents occur which could have been avoided by a few seconds of thought and a more careful approach to handling equipment. You, the operator, can avoid many accidents by observing the following precautions in this section. To avoid personal injury, study the following precautions and insist those working with you, or for you, follow them.

Replace any CAUTION, WARNING, DANGER or instruction safety decal that is not readable or is missing. Location of such decals is indicated in this booklet.

Do not attempt to operate this equipment under the influence of drugs or alcohol.

Review the safety instructions with all users annually.

This equipment is dangerous to children and persons unfamiliar with its operation. The operator should be a responsible adult familiar with farm machinery and trained in this equipment's operations. **Do not allow persons to operate or assemble this unit until they have read this manual and have developed a thorough understanding of the safety precautions and of how it works.**

To prevent injury or death, use a tractor equipped with a Roll Over Protective System (ROPS). Do not paint over, remove or deface any safety signs or warning decals on your equipment. Observe all safety signs and practice the instructions on them.

Never exceed the limits of a piece of machinery. If its ability to do a job, or to do so safely, is in question - **DON'T TRY IT.**



SAFETY DECAL CARE

- Keep safety signs clean and legible at all times.
- Replace safety signs that are missing or have become illegible.
- Replaced parts that displayed a safety sign should also display the current sign.
- Safety signs are available from your Distributor or Dealer Parts Department or the factory.

How to Install Safety Signs:

- Be sure that the installation area is clean and dry.
- Decide on the exact position before you remove the backing paper.
- Remove the smallest portion of the split backing paper.
- Align the decal over the specified area and carefully press the small portion with the exposed sticky backing in place.
- Slowly peel back the remaining paper and carefully smooth the remaining portion of the decal in place.
- Small air pockets can be pierced with a pin and smoothed out using the piece of decal backing paper.



BEFORE OPERATION

- Carefully study and understand this manual.
- Do not wear loose-fitting clothing, which may catch in moving parts.
- Always wear protective clothing and substantial shoes.
- Assure that all tires are inflated evenly.
- Give the unit a visual inspection for any loose bolts, worn parts or cracked welds, and make necessary repairs. Follow the maintenance safety instructions included in this manual.
- Be sure that there are no tools lying on or in the equipment.
- Do not use the unit until you are sure that the area is clear, especially children and animals.

- Don't hurry the learning process or take the unit for granted. Ease into it and become familiar with your new equipment.
- Practice operation of your equipment and its attachments. Completely familiarize yourself and other operators with its operation before using.
- Use a tractor equipped with a Roll Over Protective System (ROPS) and fasten your seat belt prior to starting the engine.
- The manufacturer does not recommend usage of tractor with ROPS removed.
- Move tractor wheels to the widest recommended settings to increase stability.
- Securely attach to towing unit. Use a high strength, appropriately sized hitch pin with a mechanical retainer and attach safety chain.
- Do not allow anyone to stand between the tongue or hitch and the towing vehicle when backing up to the equipment.



DURING OPERATION

- Children should not be allowed on the product.
- Clear the area of small children and bystanders before moving the feeder.
- If using a towing unit, securely attach feeder by using a hardened 3/4" pin, a metal retainer, and safety chains if required. Shift towing unit to a lower gear before going down steep downgrades, thus using the engine as a retarding force. Keep towing vehicle in gear at all times. Slow down for corners and rough terrain.
- Make sure you are in compliance with all local and state regulations regarding transporting equipment on public roads and highways. Lights and slow moving signs must be clean and visible by overtaking or oncoming traffic when feeder is transported.
- Beware of bystanders, **particularly children!** Always look around to make sure that it is safe to start the engine of the towing vehicle or move the unit. This is particularly important with higher noise levels and quiet cabs, as you may not hear people shouting.
- **NO PASSENGERS ALLOWED** - Do not carry passengers anywhere on, or in, the tractor or equipment, except as required for operation.
- Keep hands and clothing clear of moving parts.
- Do not clean, lubricate or adjust your equipment while it is moving.
- When halting operation, even periodically, set the tractor or towing vehicle brakes, disengage the PTO, shut off the engine and **remove the ignition key.**
- Be especially observant of the operating area and terrain - watch for holes, rocks or other hidden hazards. Always inspect the area prior to operation.

- **DO NOT** operate near the edge of drop-offs or banks.
- **DO NOT** operate on steep slopes as overturn may result.
- Operate up and down (not across) intermediate slopes. Avoid sudden starts and stops.



HIGHWAY AND TRANSPORT OPERATIONS

- Adopt safe driving practices:
- Keep the brake pedals latched together at all times. **NEVER USE INDEPENDENT BRAKING WITH MACHINE IN TOW AS LOSS OF CONTROL AND/OR UPSET OF UNIT CAN RESULT.**
- Always drive at a safe speed relative to local conditions and ensure that your speed is low enough for an emergency stop to be safe and secure. Keep speed to a minimum.
- Reduce speed prior to turns to avoid the risk of overturning.
- Avoid sudden uphill turns on steep slopes.
- Always keep the tractor or towing vehicle in gear to provide engine braking when going downhill. Do not coast.
- Do not drink and drive!
- Comply with state and local laws governing highway safety and movement of farm machinery on public roads.
- Use approved accessory lighting flags and necessary warning devices to protect operators of other vehicles on the highway during daylight and nighttime transport. Various safety lights and devices are available from your dealer.
- The use of flashing amber lights is acceptable in most localities. However, some localities prohibit their use. Local laws should be checked for all highway lighting and marking requirements.
- When driving the tractor and equipment on the road or highway under 40 kph (20 mph) at night or during the day, use flashing amber warning lights and a slow moving vehicle (SMV) identification emblem.
- Plan your route to avoid heavy traffic.
- Be a safe and courteous driver. Always yield to oncoming traffic in all situations, including narrow bridges, intersections, etc.
- Be observant of bridge loading ratings. Do not cross bridges rated lower than the gross weight as which you are operating.

- Watch for obstructions overhead and to the side while transporting.
- Always operate equipment in a position to provide maximum visibility at all times. Make allowances for increased length and weight of the equipment when making turns, stopping the unit, etc.
- Pick the levellest possible route when transporting across fields. Avoid the edges of ditches or gullies and steep hillsides.
- Be extra careful when working on inclines.
- Maneuver the tractor or towing vehicle at safe speeds.
- Avoid overhead wires or other obstacles. Contact with overhead lines could cause serious injury or death.
- Avoid loose fill, rocks and holes; they can be dangerous for equipment operation or movement.
- Allow for unit length when making turns.
- Operate the towing vehicle from the operator's seat only.
- Never stand alongside of unit with engine running or attempt to start engine and/or operate machine while standing alongside of unit.
- Never leave running equipment attachments unattended.
- As a precaution, always recheck the hardware on equipment following every 100 hours of operation. Correct all problems. Follow the maintenance safety procedures.

Operation



Before attaching the rotary tiller to the tractor, check the unit to ensure there is oil in the top and side gearbox. See Maintenance section for lubricant specifications.

Before beginning operation, check oil and grease points

Oil level: Top gearbox 1 1/2" from the end of the dip stick.

When sitting slightly tilted forward, oil should be at the bottom of the drain plug on the side gearbox cover.

Grease: Right Rotor bearing, PTO shaft Cross & Bearings

Attaching to the tractor

Before attaching to the tractor, be sure the lower hitch blocks are mounted so the hitch blocks are pointed forward and not upwards on the cross bar.



1. With the Rotary Tiller on a level surface, back the Cat. 1 tractor so the tractor lift arms are even with the unit's lower hitch pins. Lower or raise the tractor hitch arms until the 7/8" bushing in the arm is inside the clevis of lower hitch points. **Be sure nothing is between the tractor and the tiller before backing up.**
2. Insert the lower hitch pin through the lower hitch blocks and the tractor arm. The YCT series tillers have adjustable lower hitch blocks that can be slide to facilitate usage on larger tractors.
3. Secure the lift arm in place by using a 7/16" lynch pin or other fastener.
4. Repeat with the other arm.
5. Connect the driveline to the tractor's PTO output shaft. Secure it in place.
6. Connect the tractor top link to the upper hitch point of the rotary tiller.
7. Start the tractor and slowly raise the tiller. Check for drawbar interference. Be sure that the PTO driveline does not bottom out when lifting the machine to its maximum height. If it does appear that it could bottom out, it is necessary to shorten the PTO driveline. (See Shortening a PTO Driveline section). Ensure that in the working position there is an overlap of a minimum of 1/3 the length of each profile.

Shortening a PTO Driveline

1. With the implement attached to the tractor's three point hitch, and the PTO driveline not installed, separate the PTO driveline. Attach the implement end to the implement and the other end to the tractor PTO input shaft.
2. Raise the implement by using the tractor's hydraulic 3-point hitch to its maximum lift height.
3. Hold the half shafts next to each other and mark them so each end is approximately 1/2" from hitting the end of the telescopic profiles.
4. Shorten the inner and out guard tubes equally.
5. Shorten the inner and outer profiles by the same length as the guard tubes. Using a rattle file, round off all sharp edges and burrs. Grease the telescopic profile generously before reassembling.

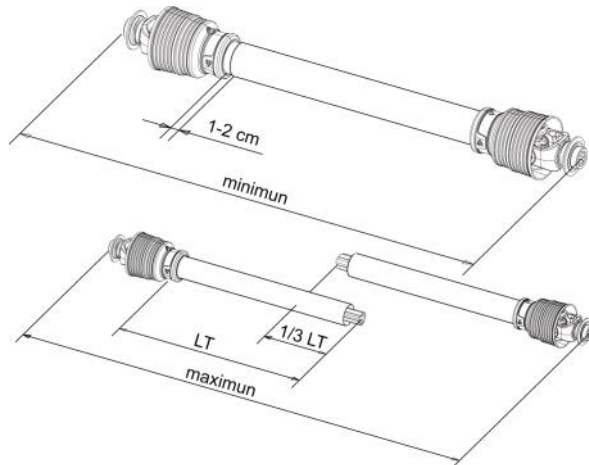



Do not shorten too much, the proper overlap is a minimum of 1/3 the length of each profile.

Caution: Slip Clutches may become hot. Do Not Touch. Keep the slip clutch area clear of an material that may catch fire.

Slip clutches have adjustable torque settings. The torque setting varies with the different compression of each spring. All the springs should have an equal amount of compression.

IMPORTANT: Do not over-tighten the compression nuts as this may impair performance or cause premature wearing of the slip clutch.

Slip Clutch adjustments

Slip Clutch must be adjusted before first use or after a storage period.

1. Using a marker, scribe a line across the exposed edges of the clutch plate and friction discs.
2. Back off compression nuts to free friction discs by turning each nut *exactly* 2 revolutions.
3. Start the tractor and run the driveline at a low idle to slip the friction discs. This will remove the dirt, corrosion and surface floss from the clutch plate faces.
4. Disengage PTO, shut down tractor and wait for all components to come to a complete stop.
5. Inspect the clutch and ensure that the scribed markings on the disc and plates have changed position. If any two marks are still aligned, this is an indication that these discs have not slipped. It may be necessary to completely disassemble the clutch to free them up.
6. After ensuring all discs are free, tighten the compression nuts, uniformly, *exactly* 2 revolutions to reset the clutch original pressure, where the springs are 1 1/4" compressed length."



Working Depth Adjustment

The working depth is controlled by raising or lowering the side skids. If the skids are raised, the working depth increases. By lowering the skids, the tilling depth with decrease.

Tailgate adjustment

The tailgate can be adjusted to help smooth and compact the tilled ground. Release the chain and secure to the desired height.

Start up

After making the necessary adjustments, lower the rotary tiller until the blades are a couple of inches from the ground. Engage the PTO and slowly lower the tiller to begin working.

Removal and Storage

After finishing, remove the rotary tiller from the tractor.

1. Put the PTO driveline in a safe location so it will not become damaged.
2. Clean and dry the equipment.
3. Replace any damaged or worn parts.
4. Check all bolts and nuts for tightness.
5. Lubricate and protect the machine from the elements.



FOLLOWING OPERATION

- Following operation, or when unhitching, stop the tractor or towing vehicle, set the brakes, disengage the PTO and all power drives, shut off the engine and **remove the ignition keys**.
- Store the unit in an area away from human activity.
- Do not park equipment where it will be exposed to livestock for long periods of time. Damage and livestock injury could result.
- Do not permit children to play on or around the stored unit.
- Make sure all parked machines are on a hard, level surface and engage all safety devices.
- Wheel chocks may be needed to prevent unit from rolling.



PERFORMING MAINTENANCE

- Good maintenance is your responsibility. Poor maintenance is an invitation to trouble.
- Make sure there is plenty of ventilation. Never operate the engine of the towing vehicle in a closed building. The exhaust fumes may cause asphyxiation.
- Be certain all moving parts on attachments have come to a complete stop before attempting to perform maintenance.
- Always use the proper tools or equipment for the job at hand.
- Use extreme caution when making adjustments.
- Never replace hex bolts with less than grade five bolts unless otherwise specified.
- After servicing, be sure all tools, parts and service equipment are removed.
- Where replacement parts are necessary for periodic maintenance and servicing, genuine factory replacement parts must be used to restore your equipment to original specifications. The manufacturer will not claim responsibility for use of unapproved parts and/or accessories and other damages as a result of their use.
- If equipment has been altered in any way from original design, the manufacturer does not accept any liability for injury or warranty.

MAINTENANCE

8 hours	Grease the Rotor support (<i>GP grease</i>) Grease PTO shaft cross & bearings (<i>GP grease</i>) Check Hardware for tightness
16 hours	Check oil level in center gearbox (<i>90wt</i>) Check oil level in side gearbox (<i>140wt</i>) Check Hardware for tightness
200 hours	Replace oil in center gearbox (<i>90wt</i>) Replace oil in side gearbox (<i>140wt</i>) Check Hardware for tightness

Replacing Blades

In order for the tiller to perform optimally, make sure the tiller blades are in good working condition and their bolts and nuts tight. Always replace the blades with the bolt head against the blade and the washer and nut on the flange side to help prevent the blades from loosening.

When several blades are to be replaced, replace them one blade at a time in order maintain the scroll pattern on the rotor.

Note: To determine Left or Right Blades, hold the blade by the bolt hole end and the cutting edge facing downward. If the blade curves to the left it is a left hand blade, curving to the right indicates a right hand blade.

Tar River Equipment

TXG-040 - TXG-050 - TXG-060

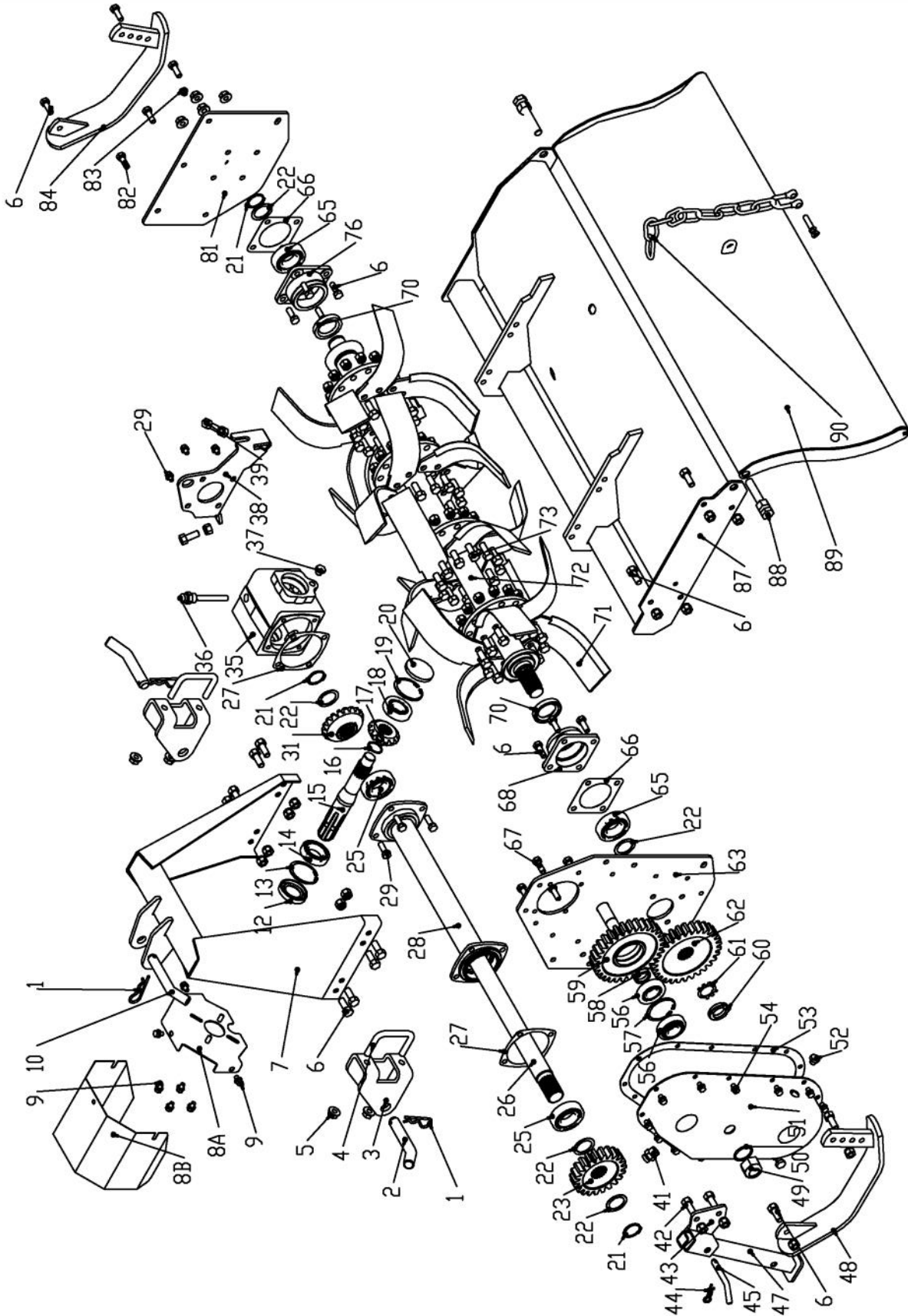

Tar River Equipment

TXG-040 - TXG-050 - TXG-060

Position	Part #	Description	Qty
1	RC400000	"R" Clip 4mm	2
2	YT1066010204	Hitch Pin	2
3	TX0202	Lower Hitch Bracket	2
4	TX0203	"U" Bolt, Lower Hitch Bracket	2
5	NM120000	Hex Nut 12MM	4
6	BM101530	Bolt 10 x 30	8
7	TX0101	A Frame	1
8A	TX030402	Support—Gearbox Shield	1
8B	TX030401	Gearbox Shield	1
9	BM812516	Bolt 8 x 1.25 x 16	4
10	YT1066010202	Top Hitch Pin	1
12	OS356210	Oil Seal 35.62.10	1
13	SRI62000	Snap Ring D.62 Internal	1
14	B6007000	Bearing 6007	1
15	TX0307	Input Shaft	1
16	SRE30000	Snap Ring D.30 External	1
17	TX0303	Pinion Gear Z-13	1
18	B30305	Bearing 30305	
19	SRI62000	Snap Ring D.62 Internal	1
20	TX0309	Gearbox Cap (Dia. 62)	1
21	SRE34000	Snap Ring D.34 External	1
22	TX0402	Shim 2mm	1
23	TX0507	Gear Drive	1
25	B62072RS	Bearing 6207-2RS	1
26	TX0304-40	Drive Shaft TXG-040	-
	TX0304-50	Drive Shaft TXG-050	-
	TX0304-60	Drive Shaft TXG-060	-
27	TX0306	Gasket - Drive shaft 112 x 96 x 0.5	1
28	TX0301-40	Drive Shaft Tube Housing TXG-040	-
	TX0301-50	Drive Shaft Tube Housing TXG-050	-
	TX0301-60	Drive Shaft Tube Housing TXG-060	-
29	BM101525	Bolt 10 x 25	4
31	TX0304	Ring Gear Z19	1
35	TX0302	Housing - Gearbox	1
36	YT10660303000	Gearbox Oil Plug	1
37	OP1212500	Oil Plug 12 x 1.25	1
38	TX0301	Lifting Hook	1
41	DP1615000V	Breather Cap M16 x 1.5 Vented	1
42	BM101525	Bolt 10 x 25	2
43	YT1066050200	Stand Bracket	1
44	RC300000	R-Clip 3mm	1
45	YT10660501	Pin - Stand	1
47	YT1066050100	Stand Leg	1
48	TX0601	Skid Weldment - Left	1
49	NM24150	Nut 24 X 1.5	1
50	OR253	O Ring - 25.X 3	1
51	TX0501	Side Gear Cover	1
52	OP1212500	Oil Plug 12 X 1.25	1
53	TX0500	Gasket - Side Gear/Chain Case	1

Tar River Equipment

TXG-040 - TXG-050 - TXG-060

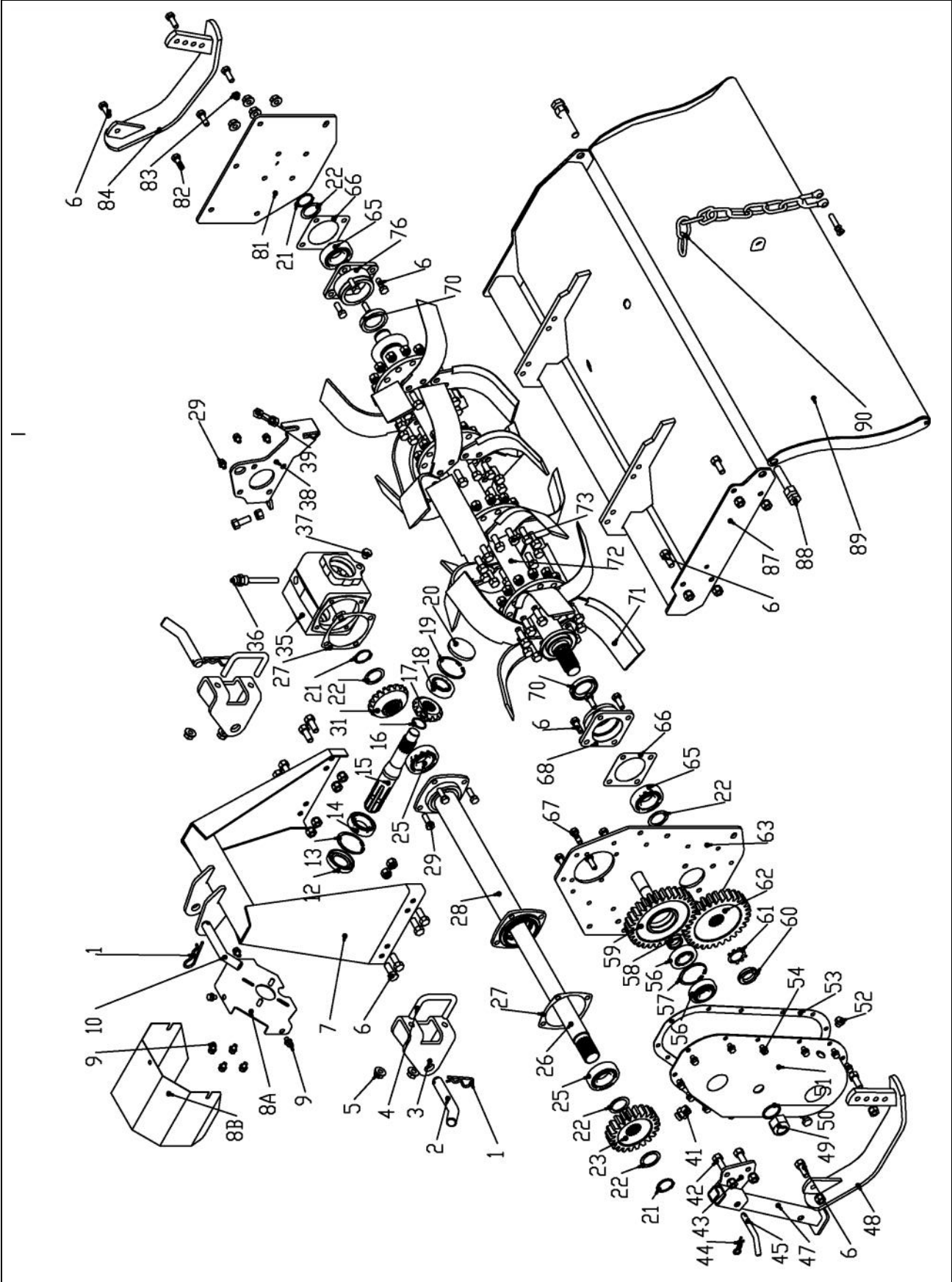

Tar River Equipment

TXG-040 - TXG-050 - TXG-060

Position	Part #	Description	Qty
54	BM812520	Bolt 8 x 1.25 x 20	13
56	B3030500	Bearing 30305	1
57	SRI62000	Snap Ring 62 Internal	1
58	TX0511	Spacer	1
59	TX0508	Idler Gear	1
60	NM30150	Nut—Rotor 30 x 1.5	1
61	SW3000	Star Washer—Rotor	1
62	TX0509	Gear - Bottom	1
63	TX0305	Side Panel - Left	1
65	B6207000	Bearing 6207	1
66	TX0406	Gasket - Rotor 102 x 73 x 0.5	1
67	BM101525	Bolt 10 x 25	4
68	TX0403	Bearing Support	1
70	OS406210	Oil Seal 40x62x10	1
71	TX0404	Blade - Left	-
	TX0405	Blade - Right	-
72	TX0401-40	Rotor - TX40	-
	TX0401-50	Rotor - TX50	-
	TX0401-60	Rotor - TX60	-
73	BM1212535	Blade Bolt - 12 x 35 Fine Thread	-
	NM120001	Nut—12mm Fine Thread	-
	LW12000	Lock Washer 12mm	-
76	TX0403	Bearing Support	1
81	TX0201	Side Panel - Right	1
82	BM101525	Bolt 10 x 25	3
83	GN06100	Grease Nipple 6mm	1
84	TX0602	Skid Weldment - Right	1
87	TX02-40	Frame Weldment TXG-040	-
	TX02-50	Frame Weldment TXG-050	-
	TX02-60	Frame Weldment TXG-060	-
88	BM1690	Bolt 16 x 90	2
	NM16000	Nut M16	
89	TX07-40	Tailgate TXG-040	-
	TX07-50	Tailgate TXG-050	-
	TX07-60	Tailgate TXG-060	-
90	TX01	Tailgate Chain assembly	1
	TXGBC1001	Gearbox Complete	-

Tar River Equipment
YCT-060 - YCT-066 - YCT-074 - YCT-082

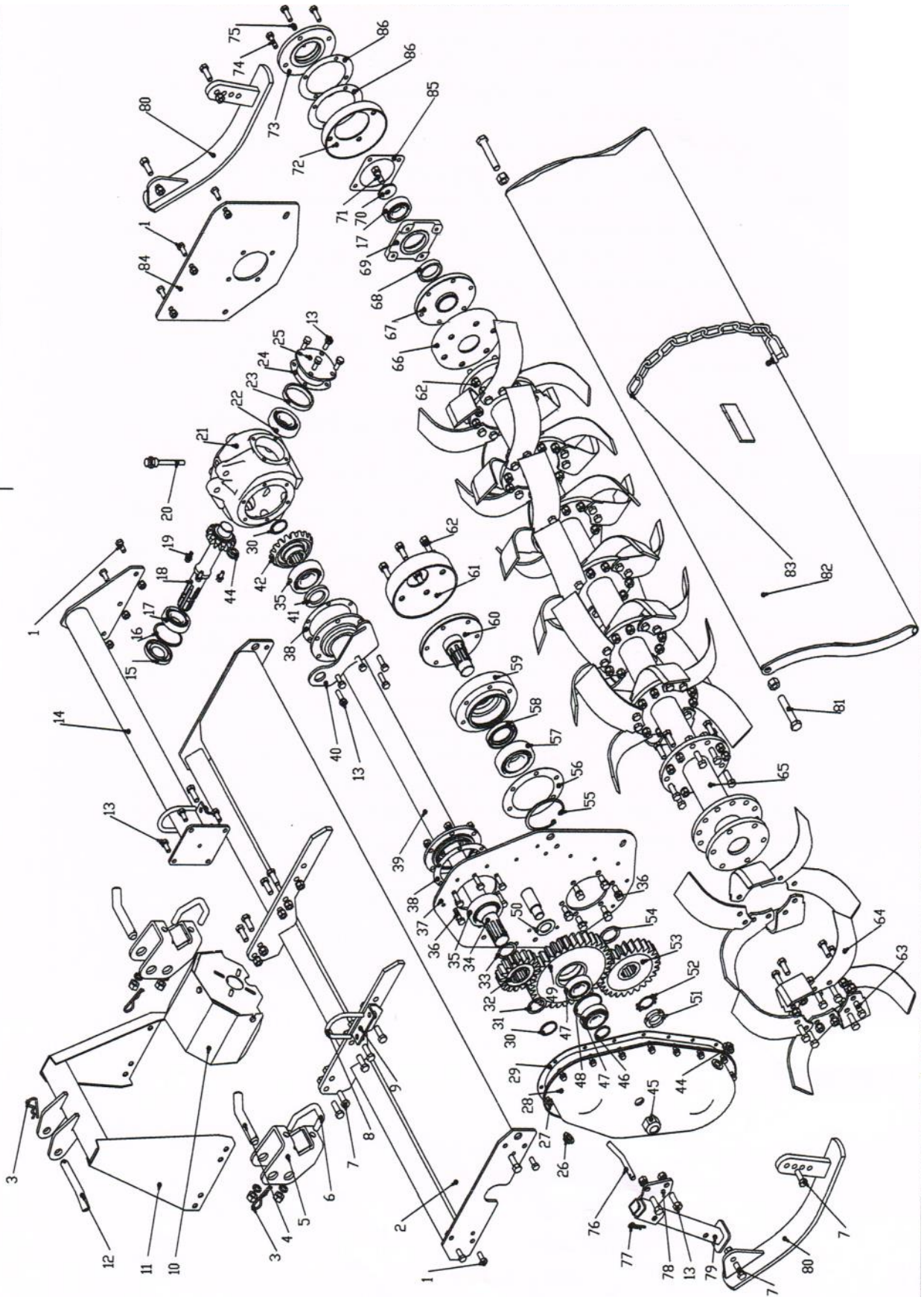

Tar River Equipment

YCT-060 - YCT-066 - YCT-074 - YCT-082

Position	Part #	Description	Qty
1	BM101525	Bolt 10 x 1.5 x 25	16
2	YT1058010100	YCT-060 Main Frame	1
	YT1066010100	YCT-066 Main Frame	1
	YT1074010100	YCT-074 Main Frame	1
	YT1082010100	YCT-082 Main Frame	1
3	RC400000	"R" Clip 4mm	3
4	YT1066010204	Top Hitch Pin	1
5	YT106601020100	Lower Hitch Bracket	2
	YT108201020100	Lower Hitch Bracket - YCT-082	2
6	YT1066010201	U Bolt, Hitch	2
	LW14000	Lock Washer 14mm	
	NM14000	Nut 14mm	
	YT1082010201	Backing Plate w/bolts - YCT-082	2
7	BM1217535	Bolt 12 x 1.75 x 35	24
8	YT10660301	U Bolt, Drivtube	1
9	YT10660302	Support - Drivtube	1
10	YT0304	PTO Shield - Complete	1
11	YT106601030100	A Frame	1
12	YT1066010202	Hitch Pin	2
13	BM101525	Bolt 10 x 1.5 x 25	4
14	YT10580400	Gearbox Support Tube YCT-060	1
	YT10660400	Gearbox Support Tube YCT-066	1
	YT10740400	Gearbox Support Tube YCT-074	1
	YT10820400	Gearbox Support Tube YCT-082	1
15	OS357210	Oil Seal 35x72x10PP	1
16	SRI72000	Snap Ring Dia. 72 - Internal	-
17	B6207000	Bearing 6207	2
18	YT10660205	Bevel Pinion Gear Shaft Z=13	1
	YT10660205R	Bevel Pinion Gear Shaft—Reverse Series	1
19	BM816000	Bolt 8 x 16 mm	3
20	YT1066020300	Gearbox Oil Plug	1
21	YT10660201	Gearbox Housing	1
22	B6307000	Bearing 6307	1
23	YT10660204	Spacer	1
24	YT10660203	Gasket Bearing Cover	1
25	YT10660202	Bearing Cover	1
26	DP1615000V	Drain Plug M16 x 1.5 Vented	1
27	BM812525	Bolt 8 x 1.25 x 25 mm	15
28	YT1066080100	Side Gear Cover	1
29	YT10660801	Gasket - Side Gear Cover	1
30	SRE40000	Snap Ring Dia. 40 - External	2
31	YT10660103	Shim 52 x 40 x 1	??
32	YT10660209	Gear Drive 17-T	1
33	YT10660208	Shim 52 x 40 x 1	??
34	YT10580210	Drive Shaft YCT-060	1
	YT10660210	Drive Shaft YCT-066	1
	YT10740210	Drive Shaft YCT-074	1
	YT10820210	Drive Shaft YCT-082	1
35	B63082RS	Bearing 6308 2RS	1
36	BM101530	Bolt 10 x 1.5 x 30	12
37	YT1066010400	Side Board - Left	1
38	YT10660207	Gasket Driveshaft 151 x 115 x .05	2
39	YT1058020100	Driveshaft Tube Housing YCT-060	1
	YT1066020100	Driveshaft Tube Housing YCT-066	1
	YT1074020100	Driveshaft Tube Housing YCT-074	1
	YT1082020100	Driveshaft Tube Housing YCT-082	1

Tar River Equipment

YCT-060 - YCT-066 - YCT-074 - YCT-082

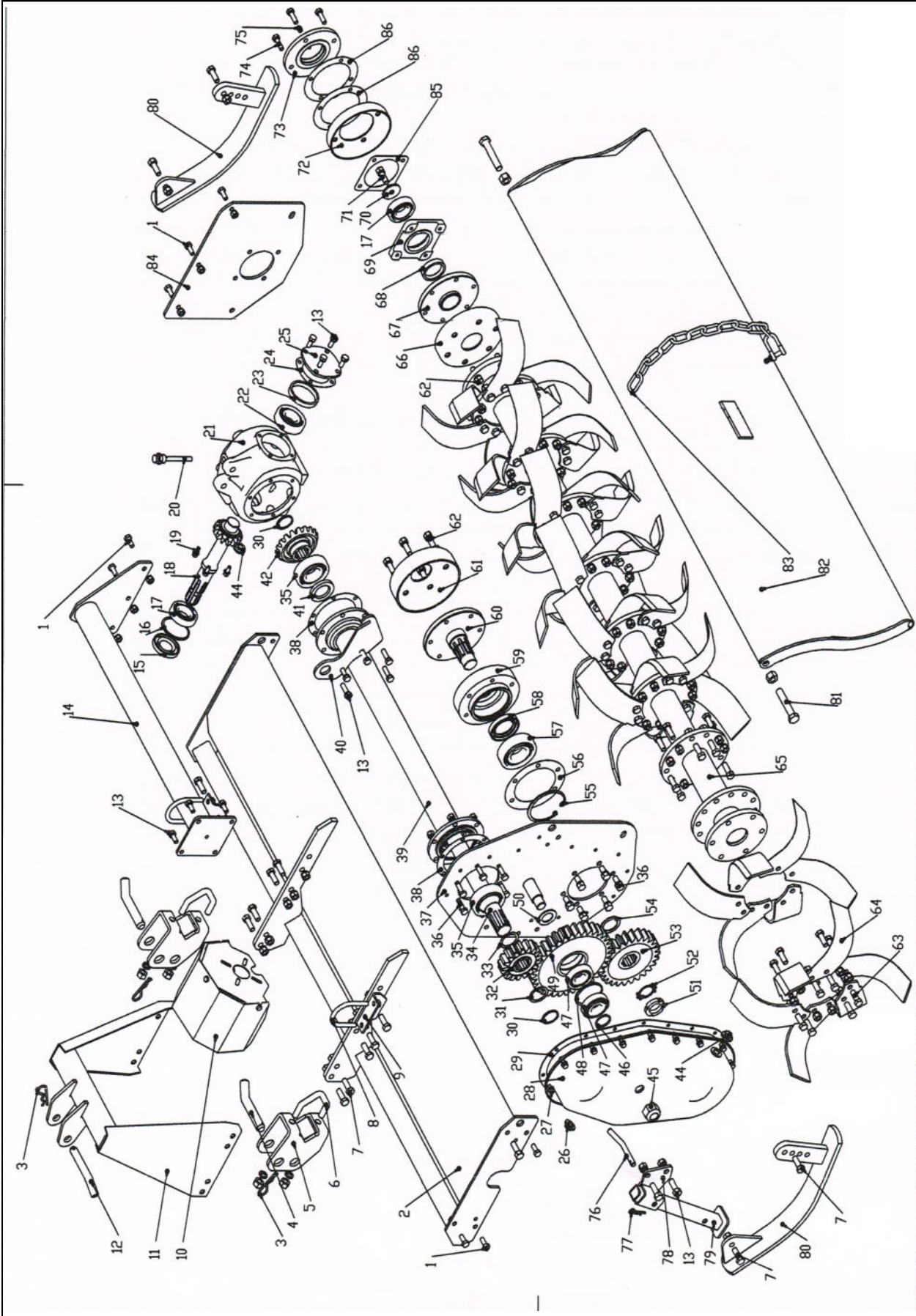

Tar River Equipment

YCT-060 - YCT-066 - YCT-074 - YCT-082

Position	Part #	Description	Qty
40	YT10660211	Lifting Hook	1
41	OS65408	Oil Seal 65 x 40 x 8	1
42	YT10660206	Output Gear	1
44	DP1415000	Drain Plug M14 x 1.5	2
45	LNM2400	Lock Nut 24mm	1
46	OR253	O-Ring	??
47	B3030600	Bearing 30306	2
48	SRI72000	Snap Ring Dia. 72 - Internal	1
49	YT10660802	Middle Gear - Side Drive	1
50	YT10660803	Idle Gear Spacer 50 x 30.2 x 2	1
51	NM3515	Nut 35mm x 1.5	1
52	LWC35	Castle Washer - 35mm	1
53	YT10660804	Gear - Rotor	1
54	YT10660806	Shim 55 x 40 x 2	1
55	SRI10000	Snap Ring Dia. 100 - Internal	1
56	YT10660808	Gasket - Drive Rotor 168 x 115 x .05	1
57	B6309000	Bearing 6309	1
58	OS805012	Oil Seal 80 x 50 x 12	1
59	YT10660805	Rotor Support - Side Drive	1
60	YT10660807	Rotor Shaft Support	1
61	YT10660809	Dust shielding	1
62	BM1217530	Bolt 12 x 1.75 x 30 mm	6
63	BM1212535	Bolt 12 x 1.25 x 35	84, 96, 108 120
	NM120001	Hex Nut 12mm	84, 96, 108 120
	LW12000	Lock Washer 12mm	84, 96, 108 120
64	YT1066090101	Tiller Tine - Right	21, 24, 27,30
	YT1066090102	Tiller Tine - Left	21, 24, 27,30
65	YT106009010100	Rotor Shaft - YCT-060	1
	YT106609010100	Rotor Shaft - YCT-066	1
	YT107409010100	Rotor Shaft - YCT-074	1
	YT108209010100	Rotor Shaft - YCT-082	1
66	YT10660901	Cover	1
67	YT10660903	Rotor Shaft Head - Right	1
68	OS456212	Oil Seal 45 x 62 x 12	1
69	YT10660904	Bearing Housing	1
70	YT10660908	Retaining Washer	1
71	BM1217525	Bolt 12 x 1.75 x 25	1
72	YT10660902	Inner Cover - Rotor Shaft	1
73	YT10660907	End Cap	1
74	BM101535	Bolt 10 x 1.5 x 35 mm	8
75	GN101500	Grease Nipple	1
76	YT10660501	Pin - Stand	1
77	RC300000	R-Clip 3mm	1
78	YT1066050200	Stand Bracket	1
79	YT1066050100	Stand Leg	1
80	YT10660600L	Skid Weldment - Left	1
80	YT10660600R	Skid Weldment - Right	1
81	BM162090	Bolt 16 x 2.0 x 90	2
82	YT1060070100	Tailgate YCT-060	1
	YT1066070100	Tailgate YCT-066	1
	YT1074070100	Tailgate YCT-074	1
	YT1082070100	Tailgate YCT-082	1
83	YT1066070200	Chain - Drag Board	1
84	YT10660101	Side Plate - Right	1
85	YT10660906	Gasket 119 x 95 x 0.5	1
86	YT10660905	Gasket 150 x 108 x .05	2
	YTGBC1001	Gearbox Complete	-

Tar River Equipment

YCT-R60 - YCT-R74 Front Shielding

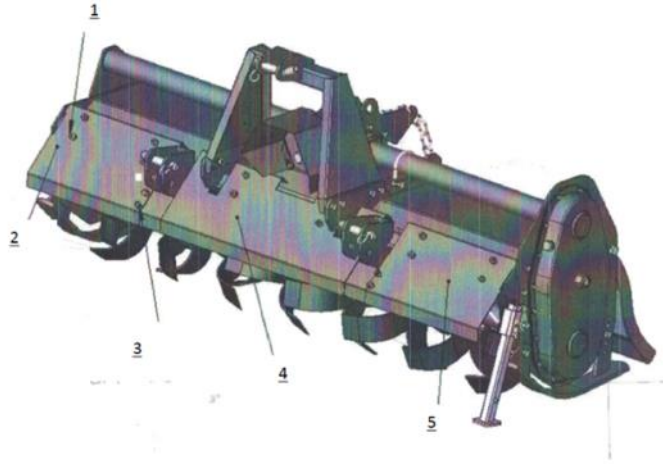

Position	Part #	Description	Qty
1	YT10660211	"U" Bolt 10mm w/ nuts	6
2	YT106075025R	Panel—60" Right	1
	YT107475025R	Panel—74" Right	1
3	BM1015025	Bolt 10 x 25mm	4
	NM1000	Nut 10mm	4
	LW1000	Lock Washer 10mm	4
4	YT106075025M	Panel—60" and 74"	1
5	YT106075025L	Panel—60" Left	1
	YT107475025L	Panel—74" Left	1
	YT106075025C	Panel—60" Complete	1
	YT107475025C	Panel—74" Complete	1

PTO Shaft

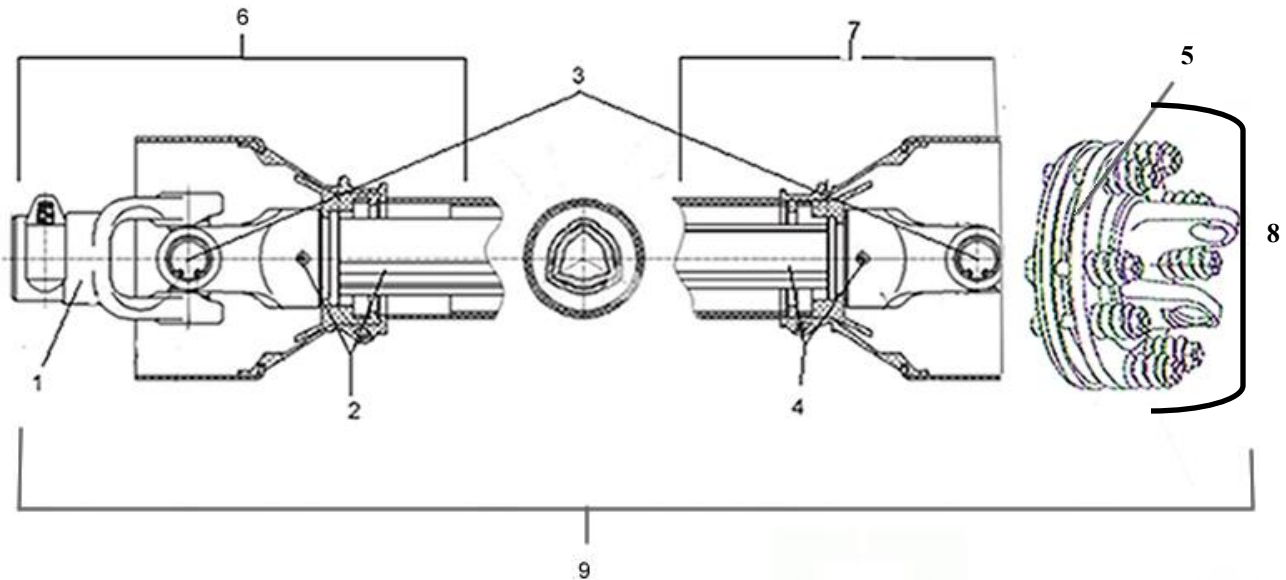

Pos.	Part #	Description	Qty
1	DP1075-40	PTO Yoke - Series 40	1
2	DP1079-40	Female Yoke and Tube (tractor end) - Series 40	1
3	DP1076-40	Cross and Bearings - Series 40	2
4	DP1078-40	Male Yoke and Tube (implement end) - Series 40	1
5	180-510-30 180-510-40	Friction Disc - 4 3/4" OD (TXG) Friction Disc - 5 1/2" OD (YCT)	2 - 4
6	DP1074F-40	Complete Female End PTO Shielding (tractor end) - Series 20-40	1
7	DP1074M-40	Complete Male End PTO Shielding (implement end) - Series 20-40	1
8	DP1098-30 DP1098-40	Slip Clutch Complete - 150 mm Clutch (2 disc) (TXG) Slip Clutch Complete - 180 mm Clutch (2 disc) (YCT)	1
9	147120 147122	Complete PTO - Series 40 - 150mm Slip Clutch (TXG) Complete PTO - Series 40 - 180mm Slip Clutch (YCT)	1
	147120-H-IE 147122-H-IE	1/2 PTO Series 40 - Implement End (with slip clutch and shielding) 1/2 PTO Series 60 - Implement End (with slip clutch and shielding)	
	147120-H-TE 147122-H-TE	1/2 PTO Series 40 - Tractor End (with shielding) 1/2 PTO Series 60 - Tractor End (with shielding)	

LIMITED WARRANTY

Tar River Equipment warrants to the original purchaser of any new piece of machinery from Tar River Equipment, purchased from an authorized Tar River Equipment dealer, that the equipment be free from defects in material and work-manship for a period of one (1) year for non-commercial, state, and municipalities' use, ninety (90) days for commercial use from date of retail sale. Warranty for rental purposes is thirty (30) days. The obligation of Tar River Equipment to the purchaser under this warranty is limited to the repair or replacement of defective parts.

A four (4) year extended **Gearbox Limited Warranty** is provided for TXG-YCT-RXT-CXT models at the end of the standard one (1) year warranty period. This warranty is not provided for commercial or rental uses. The extended warranty provides for the replacement of parts only. Not covered are oil seals or any damages to the gearbox due to lack of lubrications.

Replacement or repair parts installed in the equipment covered by this limited warranty are warranted for ninety (90) days from the date of purchase of such part or to the expiration of the applicable new equipment warranty period, whichever occurs later. Warranted parts shall be provided at no cost to the user at an authorized Tar River Equipment dealer during regular working hours. Tar River Equipment reserves the right to inspect any equipment or parts which are claimed to have been defective in material or work-manship.

This limited warranty does not apply to and excludes wear items such as shear pins, tires, tubes knives, blades or other wear items. Oil or grease is not covered by this warranty.

All obligations of Tar River Equipment under this limited warranty shall be terminated if:

- Proper service is not preformed on the machine**
- The machine is modified or altered in any way.**
- The machine is being used or has been used for purposes other than those for which the machine was intended.**

DISCLAIMER OF IMPLIED WARRANTIES & CONSEQUENTIAL DAMAGES

Tar River Equipment obligation under this limited warranty, to the extent allowed by law, is in lieu of all warranties, implied or expressed, including implied warranties of merchantability and fitness for a particular purpose and any liability for incidental and consequential damages with respect to the sale or use of the items warranted. Such incidental and consequential damages shall include but not be limited to: transportation charges other than normal freight charges; cost of installation other than cost approved by Tar River-