

# OWNER'S MANUAL

## Cimarron MC2-20HAM-KIT



**WARNING:** Cancer and Reproductive Harm.  
[www.P65Warnings.ca.gov](http://www.P65Warnings.ca.gov)



**WARNING:** To reduce the risk of injury, the user must read and understand the operator's manual before using this product.

**Any Questions, Comments or Problems: Call your nearest Cimarron Location and speak with one of our Friendly Technical Support Staff.**



[5195837 (08/23)]

<b>BAKERSFIELD, CA</b> 877-724-2236	<b>COLUMBUS, NE</b> 800-274-1025	<b>DOTHAN, AL</b> 800-227-4098	<b>FARGO, ND</b> 701-280-2862	<b>HOPKINSVILLE, KY</b> 800-637-7172	
<b>MANKATO, MN</b> 507-388-6295	<b>NEWTON, KS</b> 800-394-7662	<b>PASCO, WA</b> 800-634-2026	<b>TEMPE, AZ</b> 877-974-7166		

## Calibrating the Sprayer

When spraying with a boom, the sprayer must be calibrated to ensure proper spray coverage and to combat over-application or under application. Before calibrating the sprayer, it is important to familiarize yourself with the operating instructions.

The calibration process is simplified when broken down into the following three steps:

1. Determine the speed of the tractor
2. Determine the nozzle size and use the calibration chart to find the correct pressure setting
3. Set the pressure accordingly using the pressure regulating valve

**Note:** All calibration must be done with clean water only!

**Note: it is helpful for future references to record the exact RPM and gear that was used to attain the desired speed**

<b>Tractor RPM</b>	<b>Tractor Gear =</b>	<b>Speed</b>
_____	_____	_____

### 1. Determining the Speed

It is important to determine what speed the tractor will be traveling at, while spraying. While some tractors have speedometers, it is still recommended that speed is calculated for all tractors for accuracy purposes. To determine the speed follow these steps:

1. Set the tractor throttle to operate between 75%-100% of the tractor's RPM range. This will allow the pump to operate at full volume
2. Measure a 200 foot or 300 foot distance on a field or a surface similar to where you will be spraying
3. Drive the tractor and sprayer (tank half-full is optimal) across the measured distance at a constant rate of speed. There should be no changes in speed while you are measuring the time. This should be a comfortable speed for spraying
4. Have someone measure the amount of time (in seconds) it takes to travel the measured distance
5. Your speed can be found by entering your data into the equation below or by consulting the speed table

$$\text{Speed (MPH)} = (\text{Distance (FT)} \times 60) / (\text{Time (Seconds)} \times 88)$$

$$\text{_____ (MPH)} = \text{_____ (FT)} \times 60 / \text{_____ (SEC)} \times 88$$

**Note:** When calculating tractor speed be sure to select a gear that allows the tractor to operate between 75%-100% of the tractor's RPM range. This will allow the pump to operate at full volume. Selecting a higher gear will not allow the pump to work efficiently.

Speed Chart			
Speed in M.P.H. (Miles Per Hour)	Time Required in seconds to travel a distance of		
	100 Ft.	200 Ft.	300 Ft.
1.0	68 sec.	136	205
2.0	34	68	102
3.0	23	45	68
4.0	17	34	51
5.0	14	27	41
6.0	11	23	34
7.0	9.7	19	29
8.0	8.5	17	26
9.0	7.6	15	23
10.0	6.8	14	20

# Calibrating the Sprayer

## 2. Determine the nozzle size and use the calibration chart

Always follow the chemical manufacturers label recommendations for application rate (GPA). There are five things you will need to know to be able to figure your nozzle size and pressure setting. They are:

1. Application rate — GPA or GAL/1000 Sq. Ft.
2. Speed — MPH
3. Width — Nozzle Spacing (in inches) for broadcast boom spraying  
— Spray width (in inches) for boomless nozzles
4. Spraying Pressure — Follow chemical label recommendations for pressure/droplet size requirements
5. Solution weight and conversion factor (CF)

### Spraying Solutions Other than Water

Since all the tabulations are based on spraying water, which weighs 8.34 lbs. per USA gallon, conversion factors must be used when spraying solutions which are heavier or lighter than water. To determine the proper size nozzle for the solution to be sprayed, first multiply the desired GPM or GPA of solution by the rate conversion factor. Then use the new converted GPM or GPA rate to select the proper size nozzle and pressure.

**Example:** Desired application rate is 20 GPA of 28% Nitrogen. Determine the correct nozzle size as follows:

GPA (Solution) x Conversion Factor = Converted GPA

20 GPA (28% x 1.13 = 22.6 GPA (Water), the applicator should choose a nozzle size that will supply 22.6 GPA of water at the desired pressure.

See the appropriate **Application Chart** for your boom spraying nozzle or boomless nozzle. Using the tractor speed, nozzle width or spray width, nozzle size being used and desired gallons per acre (GPA), find the pressure (psi) necessary to achieve the desired GPA.

Weight of Solution	Specific Gravity	Conversion Factors
7.0 lbs. per gallon	.84	.92
8.0 lbs. per gallon	.96	.98
8.345 lbs. per gallon (Water)	1.00	1.00
9.0 lbs. per gallon	1.08	1.04
10.0 lbs. per gallon	1.20	1.10
10.66 lbs. per gallon (28% Nitrogen)	1.28	1.13
11.0 lbs. per gallon	1.32	1.15
12.0 lbs. per gallon	1.44	1.20
14.0 lbs. per gallon	1.68	1.30

**Example for traditional boom sprayer:** Assume you have found your tractor speed to be 6 MPH, your nozzle spacing is 20", and you want to spray 15 GPA and your sprayer has blue AIXR11003VP nozzles. Upon looking at the application chart, you will find that you should set the sprayer's pressure at about 40 psi in order to apply about 15 GPA.

**Example for boomless sprayer:** Assume you have found your tractor speed to be 5 MPH, your nozzle will cover 216 inches (18 Ft) mounted 48" height above the target spray zone, and you will want to spray 15 GPA and your sprayer has yellow XT024 nozzles. Upon looking at the application chart, you will find that you should set the sprayer's pressure at about 50 psi in order to apply about 15 GPA.

### Useful Formulas

$$\text{GPM (Per Nozzle)} = \frac{\text{GPA} \times \text{MPH} \times \text{W}}{5,940}$$

$$\text{GPM (Per Nozzle)} = \frac{\text{GAL/1000 Sq. Ft.} \times \text{MPH} \times \text{W}}{136}$$

**GPM** — Gallons Per Minute

**GPA** — Gallons Per Acre

**GAL/1000 Sq. Ft.** — Gallons Per 1000 Square Feet

**MPH** — Miles Per Hour

**W** — Nozzle Spacing (in inches) for broadcast spraying  
— Spray width (in inches) for single nozzle, Band spraying or Boomless spraying

## Calibrating the Sprayer

### 3. Adjusting the Sprayer Pressure

Once you have found the correct pressure (psi) setting, you must now adjust the sprayer to that pressure setting. Before you adjust the sprayer's pressure, it is important to follow these steps:

1. Make sure the sprayer tank is at least half full of clean water and the tank supply shutoff valve to the pump is open.
2. Make sure the pressure relief valve is backed out so at least 4 threads are showing. If not, loosen the jam nut and screw the knob out until at least 4 threads can be seen.
3. Make sure the valves to the agitator are open, if equipped.
4. With the booms on, idle tractor and engage the tractor PTO to start the pump. Slowly increase tractor RPM, paying attention to the sprayer pressure gauge. **(Do NOT spike the sprayer pressure gauge)**. If you over pressurize the spray system you can damage the pressure gauge and sprayer plumbing. Increase the tractor's RPM until you reach RPM that was used to set the tractor's speed.
5. Adjust the pressure relief valve to reach your desired psi for your speed and GPA. This is achieved by loosening the jam nut on the pressure relief valve and screwing the knob in to increase pressure and out to decrease pressure. Once you have reached your desired pressure, tighten the jam nut to lock the pressure control knob. If you can not achieve enough pressure, slowly close the agitation valve. Tighten the valve nut to lock the agitation valve, if equipped.

You have successfully calibrated the sprayer.

# Calibrating the Sprayer

## Calibration Chart

There are many different sizes and styles of spray tips available to meet your spraying needs. If you need further information, please contact an Cimarron Service Center for assistance.

**Please Note: Flow rates are calculated using fresh water.**

**Always remember to double check application rates.**

## Boomless Nozzle Application

### Hypro Boom X Tender Boomless Nozzles

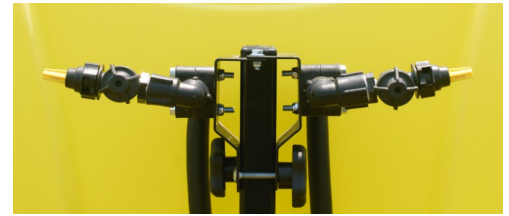

Nozzle Size (MNPT)	Pressure (PSI)	Flow Rate (GPM)	Gallons per Acre								GAL/1000 Sq. Ft.				Swath (Ft) at 40 PSI 48" High
			MPH								MPH				
			4	5	6	8	10	12	15	20	2	3	4	5	
10 (1/4")	30	0.9	8.9	7.1	5.9	4.5	3.6	3.0	2.4	1.8	0.41	0.27	0.20	0.16	13
	40	1.0	9.9	7.9	6.6	5.0	4.0	3.3	2.6	2.0	0.45	0.30	0.23	0.18	
	50	1.1	10.9	8.7	7.3	5.4	4.4	3.6	2.9	2.2	0.50	0.33	0.25	0.20	
	60	1.2	11.9	9.5	7.9	5.9	4.8	4.0	3.2	2.4	0.55	0.36	0.27	0.22	
15 (1/4")	30	1.3	10.9	8.7	7.3	5.4	4.4	3.6	2.9	2.2	0.53	0.35	0.26	0.21	14
	40	1.5	12.5	10.0	8.3	6.3	5.0	4.2	3.4	2.5	0.61	0.41	0.30	0.24	
	50	1.7	13.7	11.0	9.2	6.9	5.5	4.6	3.7	2.8	0.67	0.45	0.33	0.27	
20 (1/4")	30	1.7	13.6	10.9	9.0	6.8	5.4	4.5	3.6	2.7	0.62	0.42	0.31	0.25	15
	40	2.0	16.0	12.8	10.6	8.0	6.4	5.3	4.3	3.2	0.73	0.49	0.37	0.29	
	50	2.2	17.6	14.1	11.7	8.8	7.0	5.9	4.7	3.5	0.81	0.54	0.40	0.32	
	60	2.4	19.2	15.3	12.8	9.6	7.7	6.4	5.1	3.8	0.88	0.59	0.44	0.35	
24 (1/4")	30	2.1	16.2	13.0	10.8	8.1	6.5	5.4	4.3	3.2	0.75	0.50	0.37	0.30	16
	40	2.4	18.6	14.9	12.4	9.3	7.4	6.2	5.0	3.7	0.85	0.57	0.43	0.34	
	50	2.7	20.9	16.7	13.9	10.4	8.4	7.0	5.6	4.2	0.96	0.64	0.48	0.38	
	60	2.9	22.4	17.9	15.0	11.2	9.0	7.5	6.0	4.5	1.03	0.69	0.51	0.41	
43 (3/8")	30	3.7	31.6	25.3	21.1	15.8	12.6	10.5	8.4	6.3	1.45	0.97	0.72	0.58	14
	40	4.3	36.7	29.4	24.5	18.3	14.7	12.2	9.8	7.3	1.68	1.12	0.75	0.67	
	50	4.8	41.0	32.8	27.3	20.5	16.4	13.7	10.9	8.2	1.88	1.25	0.94	0.75	
	60	5.3	45.2	36.2	30.2	22.6	18.1	15.1	12.1	9.0	2.08	1.38	1.04	0.83	
80 (1/2")	30	6.9	68.3	54.6	45.5	34.2	27.3	22.8	18.2	13.7	3.14	2.09	1.57	1.25	13
	40	8.0	79.2	63.4	52.8	39.6	31.7	26.4	21.1	15.8	3.64	2.42	1.82	1.45	
	50	8.9	88.1	70.5	58.7	44.1	35.2	29.4	23.5	17.6	4.04	2.70	2.02	1.62	
	60	9.8	97.0	77.6	64.7	48.5	38.8	32.3	25.9	19.4	4.45	2.97	2.23	1.78	
167 (3/4")	30	14.5	128.0	103.0	85.4	64.1	51.3	42.7	34.2	25.6	5.88	3.92	2.94	2.35	15
	40	16.7	148.0	118.0	98.4	73.8	59.0	49.2	39.4	29.5	6.78	4.52	3.39	2.71	
	50	18.7	165.0	132.0	110.0	82.6	66.1	55.1	44.1	33.1	7.59	5.06	3.79	3.03	
	60	20.5	181.0	145.0	121.0	90.6	72.5	60.4	48.3	36.2	8.32	5.54	4.16	3.33	
215 (3/4")	30	18.6	144.0	115.0	95.9	71.9	57.5	48.0	38.4	28.8	6.60	4.40	3.30	2.64	16
	40	21.5	166.0	133.0	111.0	83.1	66.5	55.4	44.3	33.3	7.63	5.09	3.82	3.05	
	50	24.0	186.0	149.0	124.0	92.8	74.3	61.9	49.5	37.1	8.52	5.68	4.26	3.41	
	60	26.3	203.0	163.0	136.0	102.0	81.4	67.8	54.2	40.7	9.34	6.22	4.67	3.73	

NOTE: Application rates are based on overall swath widths listed at 48" height. Refer to operating instructions if using a different swath.

## HAMILTON BOOMLESS NOZZLES



Operating Data for 1800 Nozzles								
Orifice No.	PSI	GPM 180°	Swath 180°	Gallons per Acre				
				3 MPH	4 MPH	5 MPH	8 MPH	10 MPH
#5	30	1.7	44'	6.4	4.8	3.8	2.4	1.9
	40	2.0	46'	7.2	5.4	4.3	2.7	2.2
	50	2.2	48'	7.6	5.7	4.5	2.9	2.3
	60	2.4	50'	7.9	5.9	4.8	3.0	2.4
#10	30	3.7	50'	12.2	9.2	7.3	4.6	3.7
	40	4.2	50'	13.9	10.4	8.3	5.2	4.2
	50	4.6	52'	14.6	10.9	8.8	5.5	4.4
	60	5.0	52'	15.8	11.9	9.5	5.9	4.8
#20	30	5.1	54'	15.6	11.6	9.3	5.8	4.7
	40	5.9	54'	18.0	13.5	10.8	6.8	5.4
	50	6.7	56'	19.7	14.8	11.8	7.4	5.9
	60	7.1	58'	20.2	15.1	12.1	7.6	6.1

NOTE: 90° nozzles have the same GPA, but 1/2 GPM and swath



# Calibrating the Sprayer

## BROADCAST & TURF APPLICATION CHART—20" SPACING

Nozzle Size	Pressure (PSI)	Flow Rate (GPM)	Gallons per Acre 20-inch Nozzle Spacing										GAL/1000 Sq. Ft. 20-inch Nozzle Spacing				
			MPH										MPH				
			4	5	6	7	8	10	12	14	16	18	20	2	3	4	5
01	15	0.06	4.5	3.6	3.0	2.5	2.2	1.8	1.5	1.3	1.1	1.0	0.9	0.20	0.14	1.00	0.08
	30	0.09	6.7	5.3	4.5	3.8	3.3	2.7	2.2	1.9	1.7	1.5	1.3	0.31	0.20	0.15	0.12
	40	0.10	7.4	5.9	5.0	4.2	3.7	3.0	2.5	2.1	1.9	1.7	1.5	0.34	0.23	0.17	0.14
	60	0.12	8.9	7.1	5.9	5.1	4.5	3.6	3.0	2.5	2.2	2.0	1.8	0.41	0.27	0.20	0.16
	80	0.14	10.4	8.3	6.9	5.9	5.2	4.2	3.5	3.0	2.6	2.3	2.1	0.48	0.32	0.24	0.19
	100	0.16	11.9	9.5	7.9	6.8	5.9	4.8	4.0	3.4	3.0	2.6	2.4	0.55	0.36	0.27	0.22
115	0.17	12.6	10.1	8.4	7.2	6.3	5.0	4.2	3.6	3.2	2.8	2.5	0.58	0.39	0.29	0.23	
015	15	0.09	6.7	5.3	4.5	3.8	3.3	2.7	2.2	1.9	1.7	1.5	1.3	0.31	0.20	0.15	0.12
	30	0.13	9.7	7.7	6.4	5.5	4.8	3.9	3.2	2.8	2.4	2.1	1.9	0.44	0.30	0.22	0.18
	40	0.15	11.1	8.9	7.4	6.4	5.6	4.5	3.7	3.2	2.8	2.5	2.2	0.51	0.34	0.26	0.20
	60	0.18	13.4	10.7	8.9	7.6	6.7	5.3	4.5	3.8	3.3	3.0	2.7	0.61	0.41	0.31	0.25
	80	0.21	15.6	12.5	10.4	8.9	7.8	6.2	5.2	4.5	3.9	3.5	3.1	0.72	0.48	0.36	0.29
	100	0.24	17.8	14.3	11.9	10.2	8.9	7.1	5.9	5.1	4.5	4.0	3.6	0.82	0.55	0.41	0.33
115	0.25	18.6	14.9	12.4	10.6	9.3	7.4	6.2	5.3	4.6	4.1	3.7	0.85	0.57	0.43	0.34	
02	15	0.12	8.9	7.1	5.9	5.1	4.5	3.6	3.0	2.5	2.2	2.0	1.8	0.41	0.27	0.20	0.16
	30	0.17	12.6	10.1	8.4	7.2	6.3	5.0	4.2	3.6	3.2	2.8	2.5	0.58	0.39	0.29	0.23
	40	0.20	14.9	11.9	9.9	8.5	7.4	5.9	5.0	4.2	3.7	3.3	3.0	0.68	0.45	0.34	0.27
	60	0.24	17.8	14.3	11.9	10.2	8.9	7.1	5.9	5.1	4.5	4.0	3.6	0.82	0.55	0.41	0.33
	80	0.28	20.8	16.6	13.9	11.9	10.4	8.3	6.9	5.9	5.2	4.6	4.2	0.95	0.64	0.48	0.38
	100	0.32	23.8	19.0	15.8	13.6	11.9	9.5	7.9	6.8	5.9	5.3	4.8	1.09	0.73	0.55	0.44
115	0.34	25.2	20.2	16.8	14.4	12.6	10.1	8.4	7.2	6.3	5.6	5.0	1.16	0.77	0.58	0.46	
025	15	0.15	11.1	8.9	7.4	6.4	5.6	4.5	3.7	3.2	2.8	2.5	2.2	0.51	0.34	0.26	0.20
	30	0.22	16.3	13.1	10.9	9.3	8.2	6.5	5.4	4.7	4.1	3.6	3.3	0.75	0.50	0.38	0.30
	40	0.25	18.6	14.9	12.4	10.6	9.3	7.4	6.2	5.3	4.6	4.1	3.7	0.85	0.57	0.43	0.34
	60	0.31	23.0	18.4	15.3	13.2	11.5	9.2	7.7	6.6	5.8	5.1	4.6	1.06	0.70	0.53	0.42
	80	0.35	26.0	20.8	17.3	14.9	13.0	10.4	8.7	7.4	6.5	5.8	5.2	1.19	0.80	0.60	0.48
	100	0.40	29.7	23.8	19.8	17.0	14.9	11.9	9.9	8.5	7.4	6.6	5.9	1.36	0.91	0.68	0.55
115	0.42	31.2	24.9	20.8	17.8	15.6	12.5	10.4	8.9	7.8	6.9	6.2	1.43	0.95	0.72	0.57	
03	15	0.18	13.4	10.7	8.9	7.6	6.7	5.3	4.5	3.8	3.3	3.0	2.7	0.61	0.41	0.31	0.25
	30	0.26	19.3	15.4	12.9	11.0	9.7	7.7	6.4	5.5	4.8	4.3	3.9	0.89	0.59	0.44	0.35
	40	0.30	22.3	17.8	14.9	12.7	11.1	8.9	7.4	6.4	5.6	5.0	4.5	1.02	0.68	0.51	0.41
	60	0.37	27.5	22.0	18.3	15.7	13.7	11.0	9.2	7.8	6.9	6.1	5.5	1.26	0.84	0.63	0.50
	80	0.42	31.2	24.9	20.8	17.8	15.6	12.5	10.4	8.9	7.8	6.9	6.2	1.43	0.95	0.72	0.57
	100	0.47	34.9	27.9	23.3	19.9	17.4	14.0	11.6	10.0	8.7	7.8	7.0	1.60	1.07	0.80	0.64
115	0.51	37.9	30.3	25.2	21.6	18.9	15.1	12.6	10.8	9.5	8.4	7.6	1.74	1.16	0.87	0.70	
035	15	0.21	15.6	12.5	10.4	8.9	7.8	6.2	5.2	4.5	3.9	3.5	3.1	0.72	0.48	0.36	0.29
	30	0.30	22.3	17.8	14.9	12.7	11.1	8.9	7.4	6.4	5.6	5.0	4.5	1.02	0.68	0.51	0.41
	40	0.35	26.0	20.8	17.3	14.9	13.0	10.4	8.7	7.4	6.5	5.8	5.2	1.19	0.80	0.60	0.48
	60	0.43	31.9	25.5	21.3	18.2	16.0	12.8	10.6	9.1	8.0	7.1	6.4	1.47	0.98	0.73	0.59
	80	0.49	36.4	29.1	24.3	20.8	18.2	14.6	12.1	10.4	9.1	8.1	7.3	1.67	1.11	0.84	0.67
	100	0.55	40.8	32.7	27.2	23.3	20.4	16.3	13.6	11.7	10.2	9.1	8.2	1.88	1.25	0.94	0.75
115	0.59	43.8	35.0	29.2	25.0	21.9	17.5	14.6	12.5	11.0	9.7	8.8	2.01	1.34	1.01	0.80	
04	15	0.24	17.8	14.3	11.9	10.2	8.9	7.1	5.9	5.1	4.5	4.0	3.6	0.82	0.55	0.41	0.33
	30	0.35	26.0	20.8	17.3	14.9	13.0	10.4	8.7	7.4	6.5	5.8	5.2	1.19	0.80	0.60	0.48
	40	0.40	29.7	23.8	19.8	17.0	14.9	11.9	9.9	8.5	7.4	6.6	5.9	1.36	0.91	0.68	0.55
	60	0.49	36.4	29.1	24.3	20.8	18.2	14.6	12.1	10.4	9.1	8.1	7.3	1.67	1.11	0.84	0.67
	80	0.57	42.3	33.9	28.2	24.2	21.2	16.9	14.1	12.1	10.6	9.4	8.5	1.94	1.30	0.97	0.78
	100	0.63	46.8	37.4	31.2	26.7	23.4	18.7	15.6	13.4	11.7	10.4	9.4	2.15	1.43	1.07	0.86
115	0.68	50.5	40.4	33.9	28.9	25.2	20.2	16.8	14.4	12.6	11.2	10.1	2.32	1.55	1.16	0.93	
05	15	0.31	23.0	18.4	15.3	13.2	11.5	9.2	7.7	6.6	5.8	5.1	4.6	1.06	0.70	0.53	0.42
	30	0.43	31.9	25.5	21.3	18.2	16.0	12.8	10.6	9.1	8.0	7.1	6.4	1.47	0.98	0.73	0.59
	40	0.50	37.1	29.7	24.8	21.2	18.6	14.9	12.4	10.6	9.3	8.3	7.4	1.71	1.14	0.85	0.68
	60	0.61	45.3	36.2	30.2	25.9	22.6	18.1	15.1	12.9	11.3	10.1	9.1	2.08	1.39	1.04	0.83
	80	0.71	52.7	42.2	35.1	30.1	26.4	21.1	17.6	15.1	13.2	11.7	10.5	2.42	1.61	1.21	0.97
	100	0.79	58.7	46.9	39.1	33.5	29.3	23.5	19.6	16.8	14.7	13.0	11.7	2.69	1.80	1.35	1.08
115	0.85	63.1	50.5	42.1	36.1	31.6	25.2	21.0	18.0	15.8	14.0	12.6	2.90	1.93	1.45	1.16	
06	15	0.37	27.5	22.0	18.3	15.7	13.7	11.0	9.2	7.8	6.9	6.1	5.5	1.26	0.84	0.63	0.50
	30	0.52	38.6	30.9	25.7	22.1	19.3	15.4	12.9	11.0	9.7	8.6	7.7	1.77	1.18	0.89	0.71
	40	0.60	44.6	35.6	29.7	25.5	22.3	17.8	14.9	12.7	11.1	9.9	8.9	2.05	1.36	1.02	0.82
	60	0.73	54.2	43.4	36.1	31.0	27.1	21.7	18.1	15.5	13.6	12.0	10.8	2.49	1.66	1.24	1.00
	80	0.85	63.1	50.5	42.1	36.1	31.6	25.2	21.0	18.0	15.8	14.0	12.6	2.90	1.93	1.45	1.16
	100	0.95	70.5	56.4	47.0	40.3	35.3	28.2	23.5	20.2	17.6	15.7	14.1	3.24	2.16	1.62	1.30
115	1.02	75.7	60.6	50.5	43.3	37.9	30.3	25.2	21.6	18.9	16.8	15.1	3.48	2.32	1.74	1.39	
08	15	0.49	36.4	29.1	24.3	20.8	18.2	14.6	12.1	10.4	9.1	8.1	7.3	1.67	1.11	0.84	0.67
	30	0.69	51.2	41.0	34.2	29.3	25.6	20.5	17.1	14.6	12.8	11.4	10.2	2.35	1.57	1.18	0.94
	40	0.80	59.4	47.5	39.6	33.9	29.7	23.8	19.8	17.0	14.9	13.2	11.9	2.73	1.82	1.36	1.09
	60	0.98	72.8	58.2	48.5	41.6	36.4	29.1	24.3	20.8	18.2	16.2	14.6	3.34	2.23	1.67	1.34
	80	1.13	83.9	67.1	55.9	47.9	42.0	33.6	28.0	24.0	21.0	18.6	16.8	3.85	2.57	1.93	1.54
	100	1.26	93.6	74.8	62.4	53.5	46.8	37.4	31.2	26.7	23.4	20.8	18.7	4.30	2.86	2.15	1.72
115	1.36	101.0	80.8	67.3	57.7	50.5	40.4	33.7	28.9	25.2	22.4	20.2	4.64	3.09	2.32	1.86	
010	15	0.61	45.3	36.2	30.2	25.9	22.6	18.1	15.1	12.9	11.3	10.1	9.1	2.08	1.39	1.04	0.83
	30	0.87	64.6	51.7	43.1	36.9	32.3	25.8	21.5	18.5	16.1	14.4	12.9	2.97	1.98	1.48	1.19
	40	1.00	74.3	59.4	49.5	42.4	37.1	29.7	24.8	21.2	18.6	16.5	14.9	3.41	2.27	1.71	1.36
	60	1.22	90.6	72.5	60.4	51.8	45.3	36.2	30.2	25.9	22.6	20.1	18.1	4.16	2.77	2.08	1.66
	80	1.41	104.7	83.8	69.8	59.8	52.3	41.9	34.9	29.9	26.2	23.3	20.9	4.81	3.21	2.40	1.92
	100	1.58	117.3	93.9	78.2	67.0	58.7	46.9	39.1	33.5	29.3	26.1	23.5	5.39	3.59	2.69	2.16
115	1.70	126.2	101.0	84.2	72.1	63.1	50.5	42.1	36.1	31.6	28.1	25.2	5.80	3.86	2.90	2.32	
015	15	0.92	68.3	54.6	45.5	39.0	34.2	27.3	22.8	19.5	17.1	15.2	13.7	3.14	2.09	1.57	1.25
	30	1.30	96.														

# Calibrating the Sprayer

- 110° wide, tapered flat spray angle with air induction technology for better drift management
- Made of 2-piece UHMWPE polymer construction which provides excellent chemical resistance, including acids, as well as exceptional wear life
- Compact size to prevent tip damage
- Excellent for systemic products and drift management

## AIXR11002VP Nozzles

**AIXR11002VP Spray Tip Rate Chart (20" Spacing)**

	Pressure (psi)	Capacity (GPM)	1 MPH	2 MPH	3 MPH	4 MPH	5 MPH	6 MPH	8 MPH
Gallons Per Acre Based on Water	15	.12	35.6	17.8	11.8	8.9	7.1	5.9	4.5
	20	.14	41.6	20.8	13.8	10.4	8.3	6.9	5.2
	30	.17	50.4	25.2	16.8	12.6	10.1	8.4	6.3
	40	.20	59.6	29.8	19.8	14.9	11.9	9.9	7.4
Gallons Per 1000 Sq. Ft. Based on Water	15	.12		.41	.27	.20	.16		
	20	.14		.48	.32	.24	.19		
	30	.17		.58	.39	.29	.23		
	40	.20		.68	.45	.34	.27		

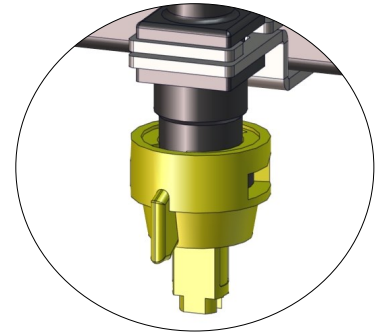

Based on the minimum overlap required to obtain uniform distribution with 110° tips and 20" spacing. Suggested Minimum Spray Height: 16"-18" above what is being sprayed (to plant, not ground). Optimum Spray Height: 20"

## AIXR110025VP Nozzles

**AIXR110025VP Spray Tip Rate Chart (20" Spacing)**

	Pressure (psi)	Capacity (GPM)	2 MPH	3 MPH	4 MPH	5 MPH	6 MPH	8 MPH	10 MPH
Gallons Per Acre Based on Water	15	.15			11.1	8.9	7.4	5.6	4.5
	20	.18			13.4	10.7	8.9	6.7	5.3
	30	.22			16.3	13.1	10.9	8.2	6.5
	40	.25			18.6	14.9	12.4	9.3	7.4
Gallons Per 1000 Sq. Ft. Based on Water	15	.15	0.51	0.34	0.26	0.20			
	20	.18	0.61	0.41	0.31	0.24			
	30	.22	0.75	0.50	0.37	0.30			
	40	.25	0.85	0.57	0.43	0.34			

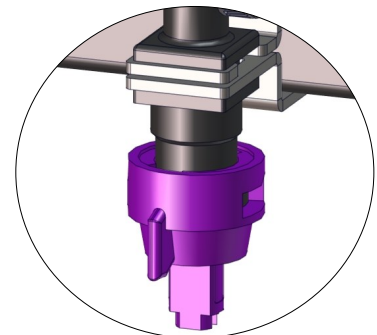

Based on the minimum overlap required to obtain uniform distribution with 110° tips and 20" spacing. Suggested Minimum Spray Height: 16"-18" above what is being sprayed (to plant, not ground). Optimum Spray Height: 20"

## AIXR11003VP Nozzles

**AIXR11003VP Spray Tip Rate Chart (20" Spacing)**

	Pressure (psi)	Capacity (GPM)	1 MPH	2 MPH	3 MPH	4 MPH	5 MPH	6 MPH	8 MPH
Gallons Per Acre Based on Water	15	.18	53.6	26.8	17.8	13.4	10.7	8.9	6.7
	20	.21	62.4	31.2	20.8	15.6	12.5	10.4	7.8
	30	.26	77.2	38.6	25.8	19.3	15.4	12.9	9.7
	40	.30	88.0	44.0	29.8	22.0	17.8	14.9	11.1
Gallons Per 1000 Sq. Ft. Based on Water	15	.18		.61	.41	.31	.24		
	20	.21		.71	.48	.36	.29		
	30	.26		.88	.59	.44	.35		
	40	.30		1.0	.68	.51	.41		

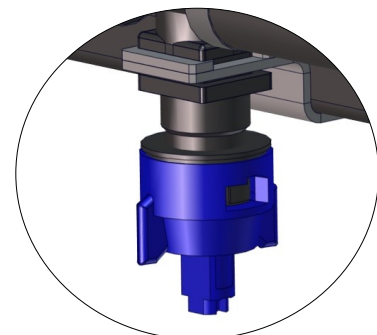

Based on the minimum overlap required to obtain uniform distribution with 110° tips and 20" spacing. Suggested Minimum Spray Height: 16"-18" above what is being sprayed (to plant, not ground). Optimum Spray Height: 20"

# Hamilton Boomless Assembly Component Breakdown & Parts List

## Hamilton #20 Boomless Kit MC1-20HAM-KIT (5282525)

Ref. #	Part #	Description	Qty
1	5070259-BLK	MC 3-PT BXT Boom Bracket	1
2	5046448	Square Cap, Black (1 1/4" Square Tube)	1
3	5282524	Hamilton #20 Boomless Assembly	1
3.1	5034609	1/4-20 x 0.50 Fing Hex Bolt	2
3.2	5095983-BLK	Boomless Nozzle Mount	2
3.3	5006344	1/4-20 Fing Top-Lock Hex Nut	4
3.4	5051174	1/2" Wet Boom Clamp (2-Piece)	1
3.5	5034615	1/4-20 x 2.00 Fing Hex Bolt (Full Thread)	2
3.6	5088026	5 Lobe Knob 1/4-20UNC	2
3.7	5034807	1/4-20 x 1.75 Carriage Bolt	2
3.8	5282523	Hamilton #20 Boomless Kit	1
3.8.1	654201	W.L. Hamilton #20 Boomless Nozzle	1
3.8.2	5011258	1/2" Pipe Nipple, 4" Long, 304 SS	1
3.8.3	5149158	Poly Elbow, 1/2" FNPT x 1/2" Hose Barb	1
4	5020099	Hose, 3/8"-2 Brd. x 25 Ft.	1
5	HC08	Hose Clamp, 1/2"	2

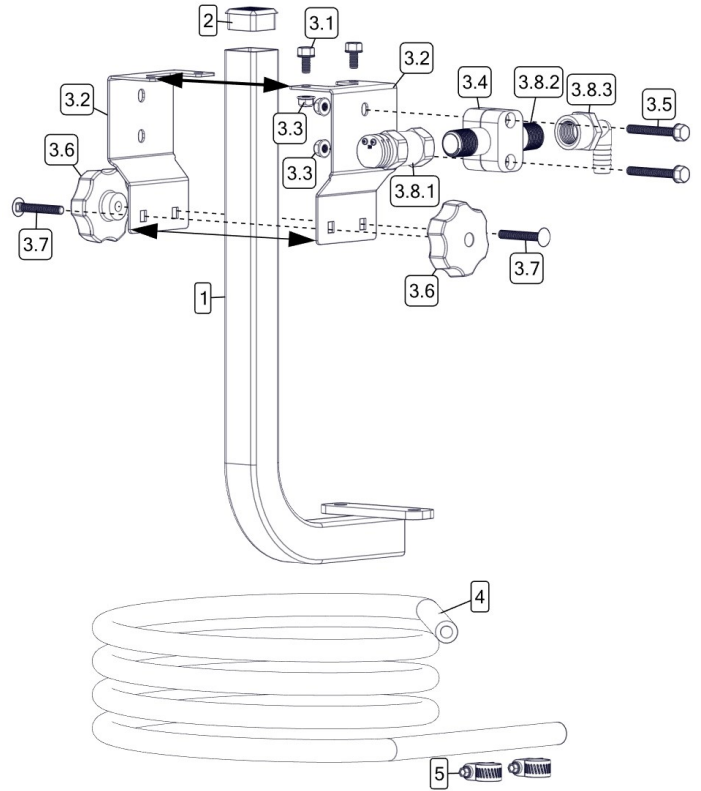



# Warranty Info

## LIMITED WARRANTY FOR NEW Cimarron EQUIPMENT

**WHO MAY USE THIS LIMITED WARRANTY.** This limited warranty (the "Limited Warranty") is provided by Fimco, Inc. ("Cimarron Equipment") to the original purchaser ("you") of the Equipment (as defined below) from Cimarron Equipment or one of Cimarron Equipment's authorized dealers. This Limited Warranty does not apply to any subsequent owner or other transferee of the Equipment. THIS LIMITED WARRANTY GIVES YOU SPECIFIC LEGAL RIGHTS, AND YOU MAY ALSO HAVE OTHER RIGHTS WHICH VARY FROM STATE TO STATE.

**WHAT THIS LIMITED WARRANTY COVERS AND FOR HOW LONG.** Cimarron Equipment warrants that any new Equipment will be free from defects in material and workmanship for a period of **one (1) year** (homeowner), **90 days** (commercial user), after delivery of the Equipment to you (the "Warranty Period"). The Warranty Period is not extended if Cimarron Equipment repairs or replaces the Equipment.

**WHAT IS NOT COVERED BY THIS LIMITED WARRANTY.** This Limited Warranty does not apply to: (1) used Equipment; (2) any Equipment that has been altered, changed, repaired or treated since its delivery to you, other than by Cimarron Equipment or its authorized dealers; (3) damage or depreciation due to normal wear and tear; (4) defects or damage due to failure to follow Cimarron Equipment's operator's manual, specifications or other written instructions, or improper storage, operation, maintenance, application or installation of parts; (5) defects or damage due to mis-use, accident or neglect, "acts of God" or other events beyond Cimarron Equipment's reasonable control; (6) accessories, attachments, tools or parts that were not manufactured by Cimarron Equipment, whether or not sold or operated with the Equipment; or (7) rubber parts, such as tires, hoses and grommets.

**HOW TO OBTAIN WARRANTY SERVICE.** To obtain warranty service under this Limited Warranty, you must (1) provide written notice to Cimarron Equipment of the defect during the Warranty Period and within **thirty (30) days** after the defect becomes apparent or the repair becomes necessary, at the following address: Cimarron Equipment, 1000 Fimco Lane, North Sioux City, SD 57049; and (2) make the Equipment available to Cimarron Equipment or an authorized dealer within a reasonable period of time. For more information about this Limited Warranty, please call: **800-274-1025**

**WHAT REMEDIES ARE AVAILABLE UNDER THIS LIMITED WARRANTY.** If the conditions set forth above are fulfilled and the Equipment or any part thereof is found to be defective, Cimarron Equipment shall, at its own cost, and at its option, either repair or replace the defective Equipment or part. Cimarron Equipment will pay for shipping and handling fees to return the repaired or replacement Equipment or part to you.

**LIMITATION OF IMPLIED WARRANTIES AND OTHER REMEDIES.** THE REMEDIES DESCRIBED ABOVE ARE YOUR SOLE AND EXCLUSIVE REMEDIES, AND Cimarron EQUIPMENT'S SOLE LIABILITY, FOR ANY BREACH OF THIS LIMITED WARRANTY. TO THE EXTENT APPLICABLE, ANY IMPLIED WARRANTIES, INCLUDING, WITHOUT LIMITATION, THE IMPLIED WARRANTIES OF MERCHANTABILITY AND FITNESS FOR A PARTICULAR PURPOSE, SHALL BE LIMITED IN DURATION TO THE WARRANTY PERIOD, AND THE REMEDIES AVAILABLE FOR BREACH THEREOF SHALL BE LIMITED TO THE REMEDIES AVAILABLE UNDER THIS EXPRESS LIMITED WARRANTY. SOME STATES DO NOT ALLOW LIMITATIONS ON HOW LONG AN IMPLIED WARRANTY LASTS, SO THE ABOVE LIMITATION MAY NOT APPLY TO YOU. IN NO EVENT SHALL Cimarron EQUIPMENT'S LIABILITY UNDER THIS LIMITED WARRANTY EXCEED THE ACTUAL AMOUNT PAID BY YOU FOR THE DEFECTIVE EQUIPMENT, NOR SHALL Cimarron EQUIPMENT BE LIABLE, UNDER ANY CIRCUMSTANCES, FOR ANY CONSEQUENTIAL, INCIDENTAL, SPECIAL OR PUNITIVE DAMAGES OR LOSSES, WHETHER DIRECT OR INDIRECT. SOME STATES DO NOT ALLOW THE EXCLUSION OR LIMITATION OF INCIDENTAL OR CONSEQUENTIAL DAMAGES, SO THE ABOVE LIMITATION OR EXCLUSION MAY NOT APPLY TO YOU.