

OWNER'S MANUAL

MX Series Boom Assemblies

Models:

MX408-QJD (5303666)

MX410-QJD (5303667)

Models:

MX412-QJD (5303668)

MX517-QJD (5282865)

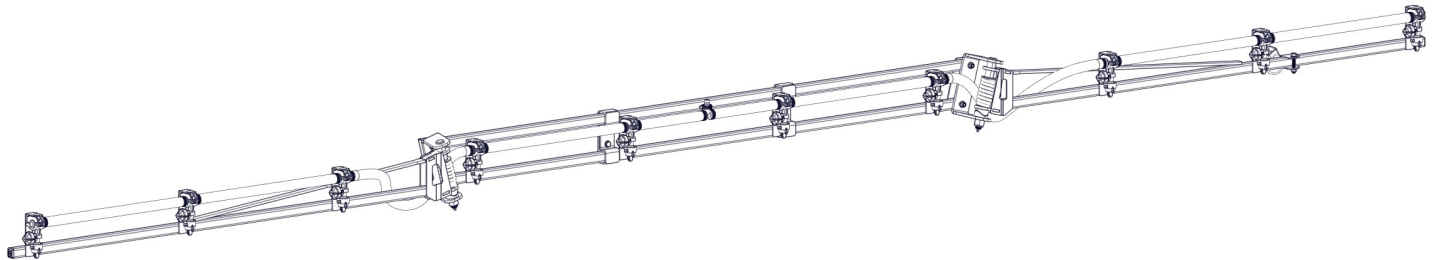

MX410-QJD (Shown)

WARNING: Always be aware of surroundings when folding and unfolding boom, especially overhead powerlines.

General Information

Thank You and Congratulations on purchasing your new boom. The purpose of this manual is to assist you in operating and maintaining your boom.

Please read it carefully, as it furnishes information which will help you achieve years of trouble-free operation.



WARNING: To reduce the risk of injury, the user must read and understand the operator's manual before using this product.



WARNING: Cancer and Reproductive Harm.
www.P65Warnings.ca.gov

Any Questions, Comments or Problems: Call your nearest Cimarron Location and speak with one of our Friendly Technical Support Staff.



[5195965

(08/23)]

BAKERSFIELD, CA 877-724-2236	COLUMBUS, NE 800-274-1025	DOTHAN, AL 800-227-4098	FARGO, ND 701-280-2862	HOPKINSVILLE, KY 800-637-7172	
MANKATO, MN 507-388-6295	NEWTON, KS 800-394-7662	PASCO, WA 800-634-2026	TEMPE, AZ 877-974-7166		

Contents

Technical Specifications	2	MX412-QJD Exploded Views/Parts List.....	8 - 9
Calibration.....	3	MX517-QJD Exploded Views/Parts List.....	10 - 11
MX408-QJD Exploded Views/Parts List	4 - 5	Warranty.....	12
MX410-QJD Exploded Views/Parts List	6 - 7		

MX Series Boom Assemblies

These booms weighs approx.:

MX408-QJD (5303666)	45 Lbs.	MX412-QJD (5303668).....	55 Lbs.
MX410-QJD (5303667)	50 Lbs.	MX517-QJD (5282865).....	95 Lbs.

**Always check the vehicle load rating before using a boom with sprayer, ensuring total weight is acceptable.
Do not exceed the recommended rating.**

~~~~~IMPORTANT~~~~~

Remove tank lid and be sure the tank is clean and free of any foreign material. Rinse tank out of any tank residue before filling with water to test.

~~~~~IMPORTANT~~~~~

It is VERY important to test the sprayer, after connecting a boom, with plain water before actual spraying is attempted. This will enable you to familiarize yourself with the sprayer and check for leaks without the possibility of losing any expensive chemicals.

~~~~~WARNING~~~~~



Read and Understand the Owner's Manual before using this boom. Test and use in accordance to instructions.
Read and Follow chemical label instructions and wear protective gear when filling, using, cleaning and servicing the boom.

Exercise Caution in vehicle handling when towing/hauling a filled sprayer to avoid loss of control or overturning.

Keep Sprayer and Spray materials away from other people, children and pets.

Do Not Turn on Power to the sprayer, until ready to spray in order to avoid unintentional spray release.

Do Not Use on steep slopes. A full sprayer could cause loss of control or overturn sprayer and vehicle.

Always operate up and down a slope, never across the face of a slope.

Keep all movement on slopes slow and gradual. Do not make sudden changes in speed, directions or turning. Do not start or stop suddenly when going uphill or downhill.

Stop on level ground, set the parking brake and shut off engine before leaving the operator's position for any reason.

Keep all parts in good condition and properly installed. Fix damaged or worn parts immediately.

Caution should be taken when towing and/or using any sprayer. The sprayer combined with the weight distribution, turning radius and speed of vehicle can result in damage to vehicle, sprayer and/or boom or severe injury or death, if not used properly.

Improper use or handling of chemicals could result in serious injury or illness, or could cause damage to the environment.

Calibration

Chemical labels may show application rates in gallons per acre, gallons per 1000 square feet or gallons per 100 square feet. You will note that the tip chart shows 2 of these rating systems.

Once you know how much you are going to spray, then determine (from the tip chart) the spraying pressure (PSI) and the spraying speed (MPH).

Determining the proper speed of the pulling vehicle can be done by marking off 100, 200 and 300 feet. The speed chart indicates the number of seconds it takes to travel the distances. Adjust the throttle until you travel the distances in the number of seconds indicated by the speed chart. Once you have reached the throttle setting needed, mark the throttle location, so you can stop and go again, returning to the same speed.

Add water and proper amount of chemical to the tank and drive to the starting place for spraying.

	Pressure (psi)	Capacity (GPM)	1 MPH	2 MPH	3 MPH	4 MPH	5 MPH	6 MPH	8 MPH
Gallons Per Acre Based on Water	15	.18	53.6	26.8	17.8	13.4	10.7	8.9	6.7
	20	.21	62.4	31.2	20.8	15.6	12.5	10.4	7.8
	30	.26	77.2	38.6	25.8	19.3	15.4	12.9	9.7
	40	.30	88.0	44.0	29.8	22.0	17.8	14.9	11.1
Gallons Per 1000 Sq. Ft. Based on Water	15	.18		.61	.41	.31	.24		
	20	.21		.71	.48	.36	.29		
	30	.26		.88	.59	.44	.35		
	40	.30		1.0	.68	.51	.41		

Speed in M.P.H. (Miles Per Hour)	Time Required in seconds to travel a distance of		
	100 Ft.	200 Ft.	300 Ft.
1.0	68 sec.	136	205
2.0	34	68	102
3.0	23	45	68
4.0	17	34	51
5.0	14	27	41
6.0	11	23	34
7.0	9.7	19	29
8.0	8.5	17	26

Tip Selection

Important Note:

The tips supplied as standard with this boom assembly are number AIXR11003VP tips, when you refer to the spray tip rate chart found in this owner's manual, you will note that they have a GPA range of 10.7 to 17.8 GPA (Gallons Per Acre). This is tabulated at 5 MPH and from 15-40 psi and 20" nozzle spacing. These rates are based on water. Please read this tip selection section carefully before attempting to operate your boom assembly.

The selection of proper tips for the boom is determined by the gallon per acre (GPA) requirement, which is specified on the chemical label. The following characteristics also have a determining factor and must be considered:

1. Speed of spraying (MPH)
2. Boom nozzle spacing (specified in inches)
3. Solution weight and conversion factor (CF)
4. Gallons of solution to be sprayed per acre
5. Spraying pressure

Nozzle Spacing

If the nozzle spacing on your boom is different from those tabulated, multiply the tabulated GPA coverage by one of the following factors.

Where Tables are Based on 20" Nozzle Spacing									
Other Spacing	8"	10"	12"	14"	16"	18"	22"	24"	30"
Conversion Factor	2.5	2	1.67	1.43	1.25	1.11	.91	.83	.66
Where Tables are Based on 30" Nozzle Spacing									
Other Spacing	26"	28"	32"	34"	36"	38"	40"	42"	44"
Conversion Factor	1.15	1.07	.94	.88	.83	.79	.75	.71	.68
Where Tables are Based on 40" Nozzle Spacing									
Other Spacing	28"	30"	32"	34"	36"	38"	42"	44"	48"
Conversion Factor	1.43	1.33	1.25	1.18	1.11	1.05	.95	.91	.83

Based on the minimum overlap required to obtain uniform distribution with 110° tips and 20" spacing.

Suggested Minimum Spray Height: 16"-18" above what is being sprayed (to plant, not ground).

Optimum Spray Height: 20"

- 110° wide, tapered flat spray angle with air induction technology for better drift management
- Made of 2-piece UHMWPE polymer construction which provides excellent chemical resistance, including acids, as well as exceptional wear life
- Compact size to prevent tip damage
- Excellent for systemic products and drift management

MX408-QJD (5303666) Series Boom Component Breakdown & Parts List

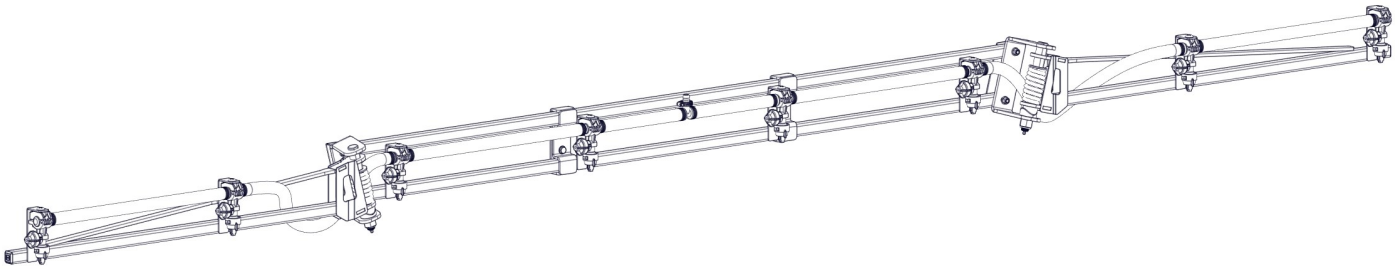

Ref. #	Part #	Description	Qty
1	5034637	5/16-18 x 1.25 Flng Hex Bolt	4
2	5051179-BLK	MX4 Saddle Mount Clamp	2
3	5282551-BLK	MX4 Center Section	1
4	5029212-BLK	MX4 Saddle Base	2
5	5006389	5/16-18 Flng Top-Lock Hex Nut	8
6	5034871	5/16-18 x 1.75 Carriage Bolt	4
7	5282563	MX4 2-Nozzle Wing Assembly, LH	1
7.1	5282560-BLK	MX4, LH Wing Mount	1
7.2	5101378	Pivot Pin	1
7.3	5282554-BLK	MX4 2-Nozzle Wing, LH	1
7.4	5016323	3/4 (.785) X 1.50" OD Flat Washer	1
7.5	5019762	Compression Spring, 3.75"	1
7.6	5006401	5/8-18 Nylock Hex Nut	1
7.7	5012025	3/16" Straight Drive Ball Check Grease Fitting	1
7.8	5046106	1" Square Cap, Black	1
8	5282564	MX4 2-Nozzle Wing Assembly, RH	1
8.1	5282561-BLK	MX4, RH Wing Mount	1
8.2	5101378	Pivot Pin	1
8.3	5282555-BLK	MX4 2-Nozzle Wing, RH	1
8.4	5016323	3/4 (.785) x 1.50" OD Flat Washer	1
8.5	5019762	Compression Spring, 3.75"	1
8.6	5006401	5/8-18 Nylock Hex Nut	1

Ref. #	Part #	Description	Qty
8.7	5012025	3/16" Straight Drive Ball Check Grease Fitting	1
8.8	5046106	1" Square Cap, Black	1
9	5034879	5/16-18 x 0.50 Phillips Truss Head Locking Screw	8
10	5282569	MX4 Boom Harness, 1-Way for Center	1
10.1	5086026	Poly Hose Tee, 1/2" HB	1
10.2	5020572	Hose, 1/2"-1 Brd. x 10"	2
10.3	5051114	Hose Clamp (1/2")	10
10.4	5002522	QJ17560A-1/2 w/AIXR11003 x 1/2 HB Tee	4
10.5	5020977	Hose, 1/2" (2SP) x 18-1/2" NBR & PVC	2
10.6	5020576	Hose, 1/2" (2SP) X 26"	2
11	5282570	MX4 LH Boom Harness, 2-Nozzle Wing	1
11.1	5002522	QJ17560A-1/2 w/AIXR11003 x 1/2 HB Tee	1
11.2	5020977	Hose, 1/2" (2SP) x 18-1/2" NBR & PVC	1
11.3	5051114	Hose Clamp (1/2")	2
11.4	5002523	QJ17560A-1/2 w/AIXR11003 x 1/2 HB Single (LH)	1
12	5282571	MX4 RH Boom Harness, 2-Nozzle Wing	1
12.1	5002522	QJ17560A-1/2 w/AIXR11003 x 1/2 HB Tee	1
12.2	5020977	Hose, 1/2" (2SP) x 18-1/2" NBR & PVC	1
12.3	5051114	Hose Clamp (1/2")	2
12.4	5002524	QJ17560A-1/2 w/AIXR11003 x 1/2 HB Single (RH)	1
13	5051114	Hose Clamp (1/2")	3

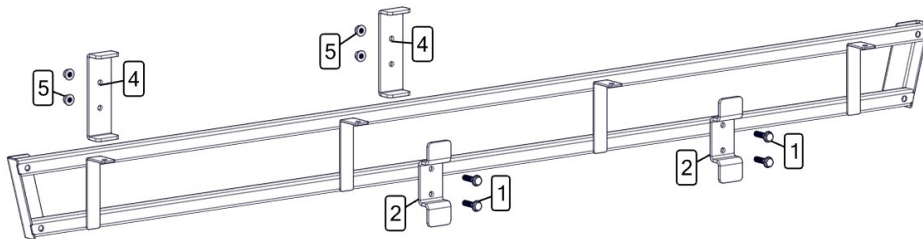

MX4 Center Section

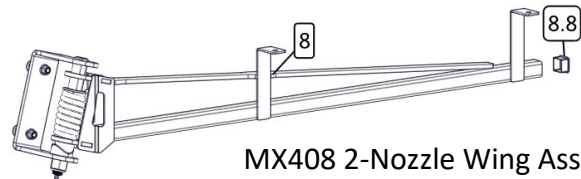

MX408 2-Nozzle Wing Assembly (RH)

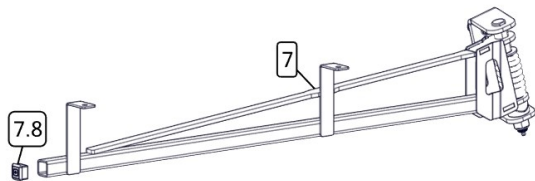

MX408 2-Nozzle Wing Assembly (LH)

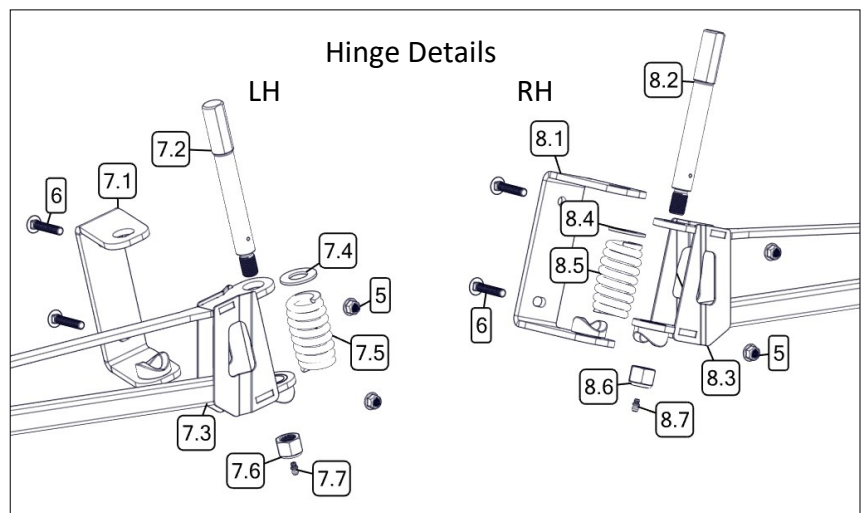

Hinge Details

MX408-QJD (5303666) Series Boom Component Breakdown & Parts List

MX4 Center Boom Harness

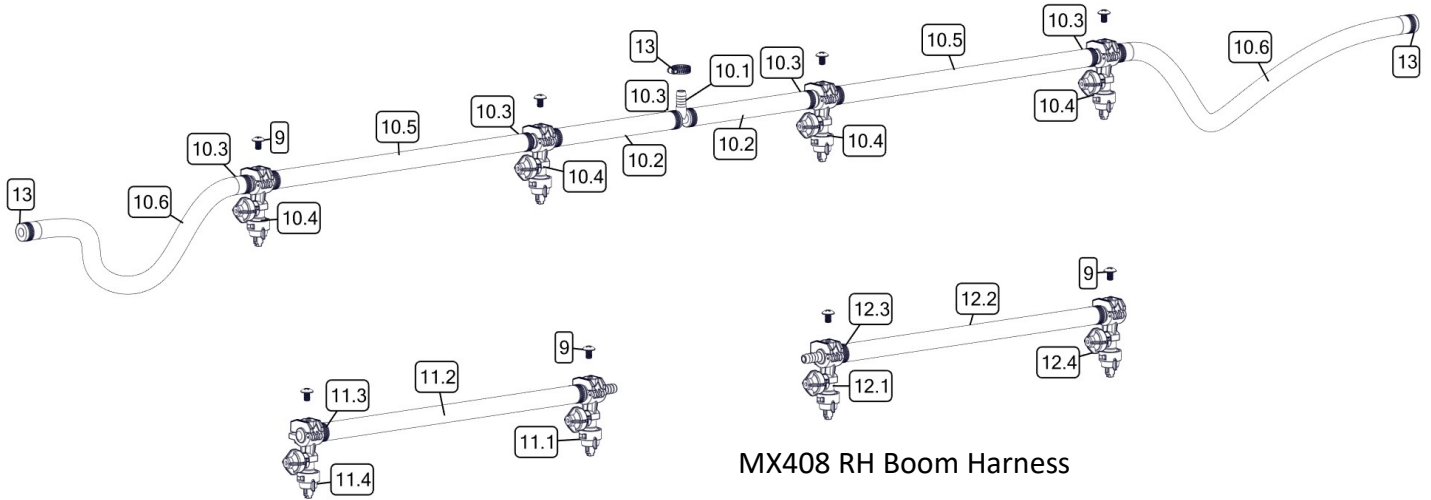

MX408 RH Boom Harness

MX408 LH Boom Harness

5002523
LH Nozzle Assy

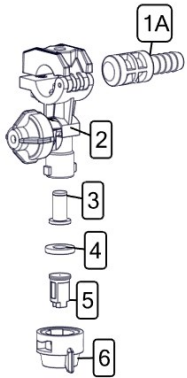

5002522
Nozzle Assy

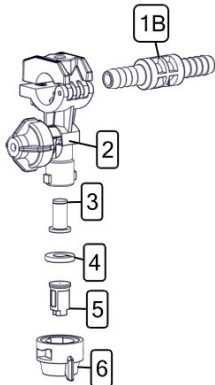

5002524
RH Nozzle Assy

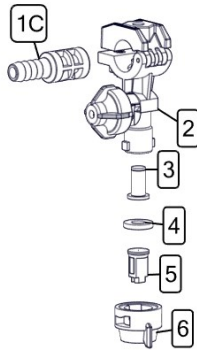

The AIXR TeeJet Flat Spray Tip offers the benefits of obtaining excellent drift resistance without compromising spray coverage. Tips producing very coarse droplets do minimize drift but do not provide the same surface coverage as tips that produce smaller droplets. In some applications, inadequate coverage decreases the effectiveness of the applied chemicals.

AIXR Features and Benefits

- 110° wide, tapered flat spray angle with air induction technology for better drift management
- Made of 2-piece UHMWPE polymer construction which provides excellent chemical resistance, including acids, as well as exceptional wear life
- Compact size to prevent tip damage
- Removable pre-orifice
- Excellent for systemic products and drift management

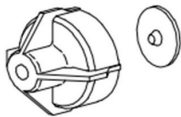

Check Valve Cap: 5046113
Diaphragm: 5063132

Ref. #	Part #	Description	Qty
1A	5002514	Single 1/2" Dry Boom Nozzle Adapter	1
1B	5002513	Double 1/2" Dry Boom Nozzle Adapter	1
1C	5002514	Single 1/2" Dry Boom Nozzle Adapter	1
2	5056125	QJ17560A-1/2 1/2" Wet Boom QJ Nozzle Body	3
3	5116019	Nozzle Strainer, Blue (50 Mesh)	3
4	5016157	Seat Washer - EPDM - QJ Caps	3
5	AIXR11003VP	Air-Induction XR Flat Spray Tip	3
6	5046217	Quick Cap - Blue	3
7	5034873	5/16-18 Low Profile Hex Nut (Not Shown)	3

MX410-QJD (5303667) Series Boom Component Breakdown & Parts List

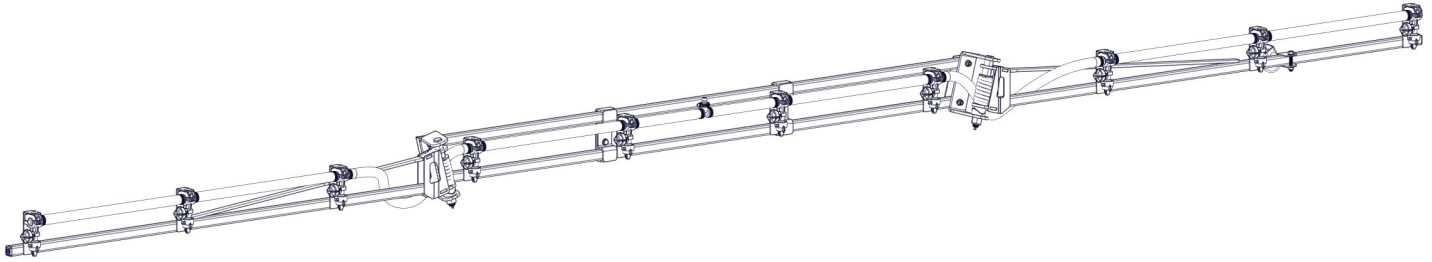

Ref. #	Part #	Description	Qty
1	5034637	5/16-18 x 1.25 Fling Hex Bolt	4
2	5051179-BLK	MX4 Saddle Mount Clamp	2
3	5282551-BLK	MX4 Center Section	1
4	5029212-BLK	MX4 Saddle Base	2
5	5006389	5/16-18 Fling Top-Lock Hex Nut	9
6	5034871	5/16-18 x 1.75 Carriage Bolt	4
7	5282565	MX4 3-Nozzle Wing Assembly, LH	1
7.1	5282560-BLK	MX4, LH Wing Mount	1
7.2	5101378	Pivot Pin	1
7.3	5282556-BLK	MX4 3-Nozzle Wing, LH	1
7.4	5016323	3/4 (.785) X 1.50" OD Flat Washer	1
7.5	5019762	Compression Spring, 3.75"	1
7.6	5006401	5/8-18 Nylock Hex Nut	1
7.7	5012025	3/16" Straight Drive Ball Check Grease Fitting	1
7.8	5046106	1" Square Cap, Black	1
8	5282566	MX4 3-Nozzle Wing Assembly, RH	1
8.1	5282561-BLK	MX4, RH Wing Mount	1
8.2	5101378	Pivot Pin	1
8.3	5282557-BLK	MX4 3-Nozzle Wing, RH	1
8.4	5016323	3/4 (.785) X 1.50" OD Flat Washer	1
8.5	5019762	Compression Spring, 3.75"	1
8.6	5006401	5/8-18 Nylock Hex Nut	1
8.7	5012025	3/16" Straight Drive Ball Check Grease Fitting	1
8.8	5046106	1" Square Cap, Black	1

Ref. #	Part #	Description	Qty
9	5034879	5/16-18 x 0.50 Phillips Truss Head Locking Screw	10
10	5282569	MX4 Boom Harness, 1-Way for Center	1
10.1	5086026	Poly Hose Tee, 1/2" HB	1
10.2	5020572	Hose, 1/2"-1 Brd. x 10"	2
10.3	5051114	Hose Clamp (1/2")	10
10.4	5002522	QJ17560A-1/2 w/AIXR11003 x 1/2 HB Tee	4
10.5	5020977	Hose, 1/2" (2SP) x 18-1/2" NBR & PVC	2
10.6	5020576	Hose, 1/2" (2SP) X 26"	2
11	5282572	MX4 LH Boom Harness, 3-Nozzle Wing	1
11.1	5002522	QJ17560A-1/2 w/AIXR11003 x 1/2 HB Tee	2
11.2	5020977	Hose, 1/2" (2SP) x 18-1/2" NBR & PVC	2
11.3	5051114	Hose Clamp (1/2")	4
11.4	5002523	QJ17560A-1/2 w/AIXR11003 x 1/2 HB Single (LH)	1
12	5282573	MX4 RH Boom Harness, 3-Nozzle Wing	1
12.1	5002522	QJ17560A-1/2 w/AIXR11003 x 1/2 HB Tee	2
12.2	5020977	Hose, 1/2" (2SP) x 18-1/2" NBR & PVC	2
12.3	5051114	Hose Clamp (1/2")	4
12.4	5002524	QJ17560A-1/2 w/AIXR11003 x 1/2 HB Single (RH)	1
13	5051114	Hose Clamp (1/2")	3
14	5034639	5/16-18 x 1.75 Fling Hex Bolt (Full Thread)	1
15	5282562-BLK	MX4 Boom Wing Lock	1
16	5101260	5/16" x 1-3/4" Lynch Pin	1

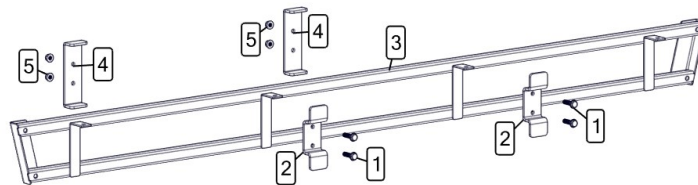

MX4 Center Section

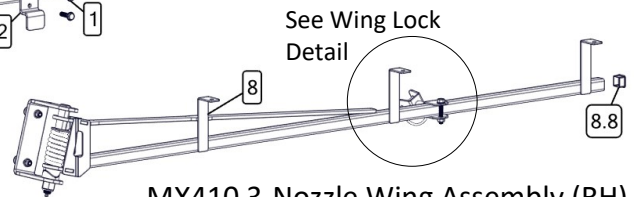

MX410 3-Nozzle Wing Assembly (RH)

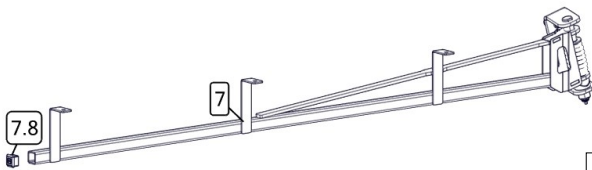

MX410 3-Nozzle Wing Assembly (LH)

Wing Lock Detail

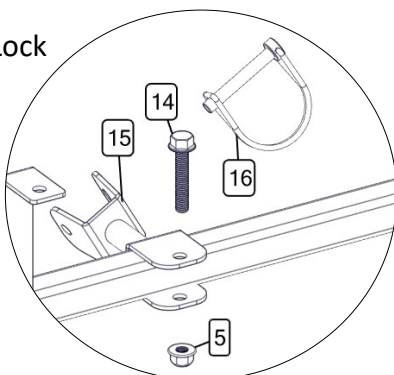

Hinge Details

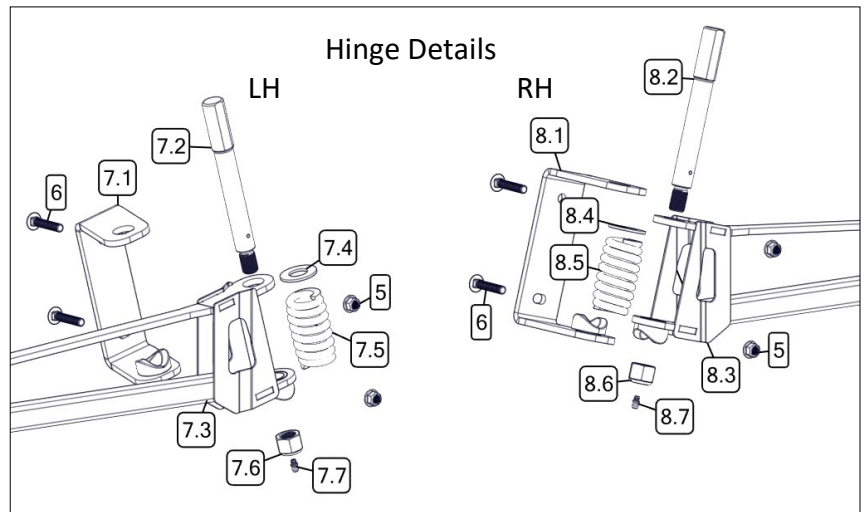

MX410-QJD (5303667) Series Boom Component Breakdown & Parts List

MX4 Center Boom Harness

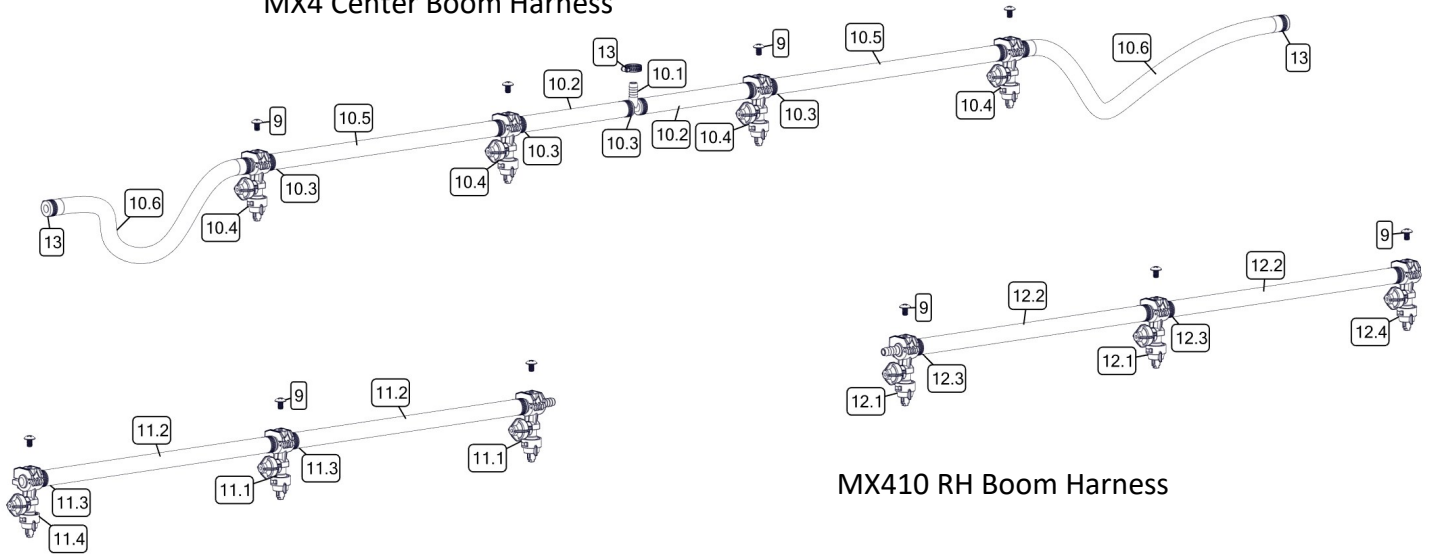

MX410 LH Boom Harness

MX410 RH Boom Harness

**5002523
LH Nozzle Assy**

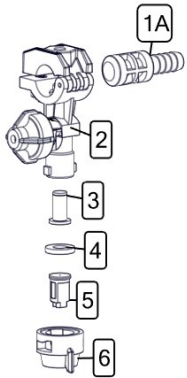

**5002522
Nozzle Assy**

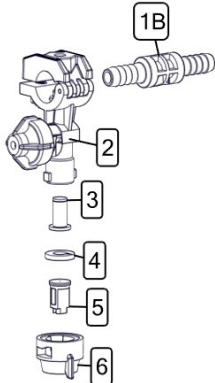

**5002524
RH Nozzle Assy**

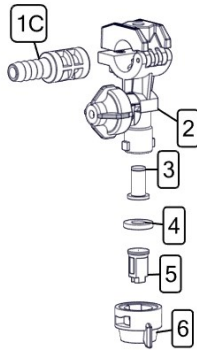

The AIXR TeeJet Flat Spray Tip offers the benefits of obtaining excellent drift resistance without compromising spray coverage. Tips producing very coarse droplets do minimize drift but do not provide the same surface coverage as tips that produce smaller droplets. In some applications, inadequate coverage decreases the effectiveness of the applied chemicals.

AIXR Features and Benefits

- 110° wide, tapered flat spray angle with air induction technology for better drift management
- Made of 2-piece UHMWPE polymer construction which provides excellent chemical resistance, including acids, as well as exceptional wear life
- Compact size to prevent tip damage
- Removable pre-orifice
- Excellent for systemic products and drift management

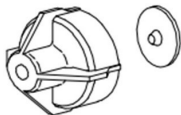

Check Valve Cap: 5046113
Diaphragm: 5063132

Ref. #	Part #	Description	Qty
1A	5002514	Single 1/2" Dry Boom Nozzle Adapter	1
1B	5002513	Double 1/2" Dry Boom Nozzle Adapter	1
1C	5002514	Single 1/2" Dry Boom Nozzle Adapter	1
2	5056125	QJ17560A-1/2 1/2" Wet Boom QJ Nozzle Body	3
3	5116019	Nozzle Strainer, Blue (50 Mesh)	3
4	5016157	Seat Washer - EPDM - QJ Caps	3
5	AIXR11003VP	Air-Induction XR Flat Spray Tip	3
6	5046217	Quick Cap - Blue	3
7	5034873	5/16-18 Low Profile Hex Nut (Not Shown)	3

MX412-QJD (5303668) Series Boom Component Breakdown & Parts List

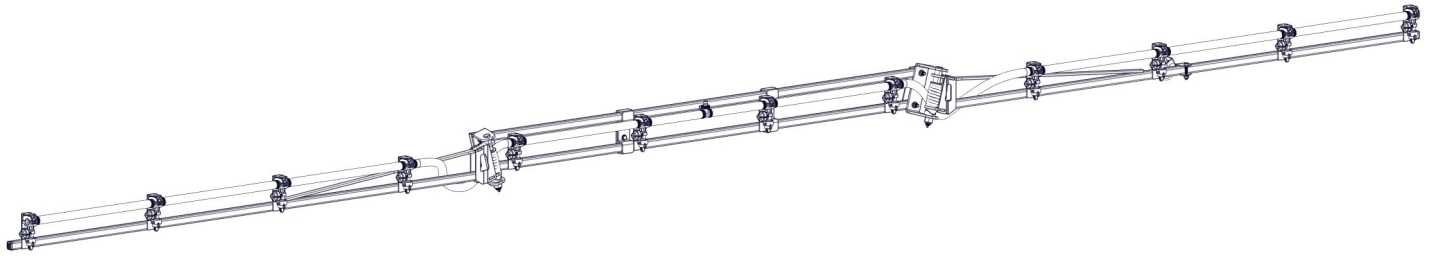

Ref. #	Part #	Description	Qty
1	5034637	5/16-18 x 1.25 Fling Hex Bolt	4
2	5051179-BLK	MX4 Saddle Mount Clamp	2
3	5282551-BLK	MX4 Center Section	1
4	5029212-BLK	MX4 Saddle Base	2
5	5006389	5/16-18 Fling Top-Lock Hex Nut	5
6	5034485	3/8-16 x 2.00 Carriage Bolt	4
7	5282567	MX4 4-Nozzle Wing Assembly, LH	1
7.1	5282560-BLK	MX4, LH Wing Mount	1
7.2	5101378	Pivot Pin	1
7.3	5282558-BLK	MX4 4-Nozzle Wing, LH	1
7.4	5016323	3/4 (.785) X 1.50" OD Flat Washer	1
7.5	5019762	Compression Spring, 3.75"	1
7.6	5006401	5/8-18 Nylock Hex Nut	1
7.7	5012025	3/16" Straight Drive Ball Check Grease Fitting	1
7.8	5046106	1" Square Cap, Black	1
8	5282568	MX4 4-Nozzle Wing Assembly, RH	1
8.1	5282561-BLK	MX4, RH Wing Mount	1
8.2	5101378	Pivot Pin	1
8.3	5282559-BLK	MX4 4-Nozzle Wing, RH	1
8.4	5016323	3/4 (.785) X 1.50" OD Flat Washer	1
8.5	5019762	Compression Spring, 3.75"	1
8.6	5006401	5/8-18 Nylock Hex Nut	1
8.7	5012025	3/16" Straight Drive Ball Check Grease Fitting	1
8.8	5046106	1" Square Cap, Black	1

Ref. #	Part #	Description	Qty
9	5034879	5/16-18 x 0.50 Phillips Truss Head Locking Screw	12
10	5282569	MX4 Boom Harness, 1-Way for Center	1
10.1	5086026	Poly Hose Tee, 1/2" HB	1
10.2	5020572	Hose, 1/2"-1 Brd. x 10"	2
10.3	5051114	Hose Clamp (1/2")	10
10.4	5002522	QJ17560A-1/2 w/AIXR11003 x 1/2 HB Tee	4
10.5	5020977	Hose, 1/2" (2SP) x 18-1/2" NBR & PVC	2
10.6	5020576	Hose, 1/2" (2SP) X 26"	2
11	5282574	MX4 LH Boom Harness, 4-Nozzle Wing	1
11.1	5002522	QJ17560A-1/2 w/AIXR11003 x 1/2 HB Tee	3
11.2	5020977	Hose, 1/2" (2SP) x 18-1/2" NBR & PVC	3
11.3	5051114	Hose Clamp (1/2")	6
11.4	5002523	QJ17560A-1/2 w/AIXR11003 x 1/2 HB Single (LH)	1
12	5282575	MX4 RH Boom Harness, 4-Nozzle Wing	1
12.1	5002522	QJ17560A-1/2 w/AIXR11003 x 1/2 HB Tee	3
12.2	5020977	Hose, 1/2" (2SP) x 18-1/2" NBR & PVC	3
12.3	5051114	Hose Clamp (1/2")	6
12.4	5002524	QJ17560A-1/2 w/AIXR11003 x 1/2 HB Single (RH)	1
13	5051114	Hose Clamp (1/2")	3
14	5034639	5/16-18 x 1.75 Fling Hex Bolt (Full Thread)	1
15	5282562-BLK	MX4 Boom, Wing Lock	1
16	5101260	5/16" x 1-3/4" Lynch Pin	1
17	5006345	3/8-16 Fling Top-Lock Hex Nut	4

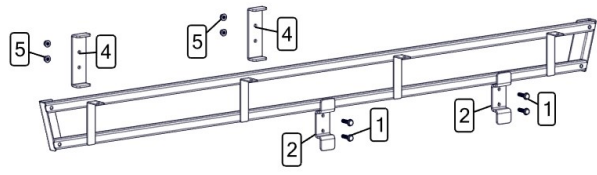

MX4 Center Section

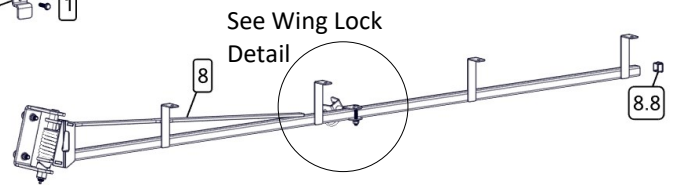

MX412 4-Nozzle Wing Assembly (RH)

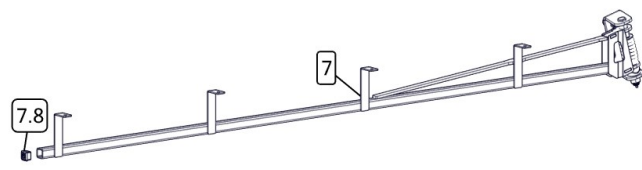

MX412 4-Nozzle Wing Assembly (LH)

Wing Lock Detail

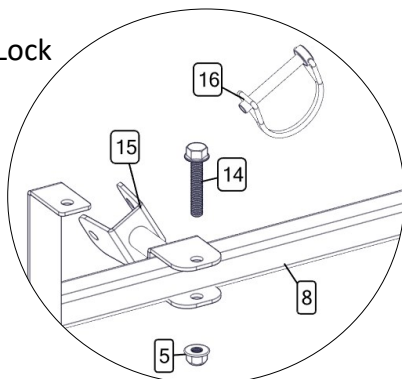

Hinge Details

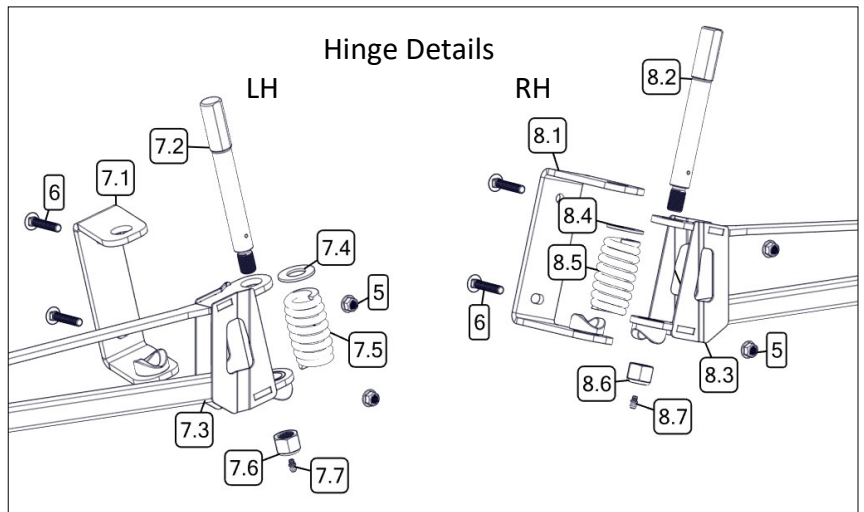

MX412-QJD (5303668) Series Boom Component Breakdown & Parts List

MX4 Center Boom Harness

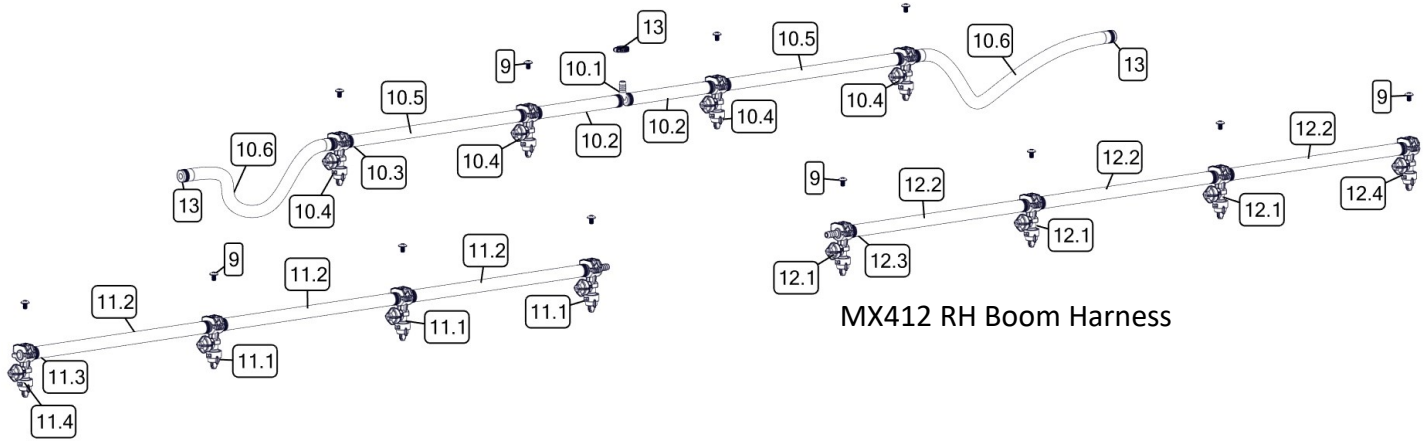

MX412 LH Boom Harness

5002523
LH Nozzle Assy

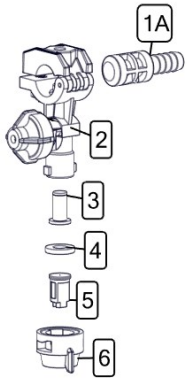

5002522
Nozzle Assy

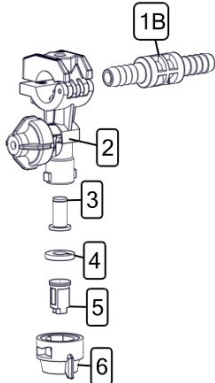

5002524
RH Nozzle Assy

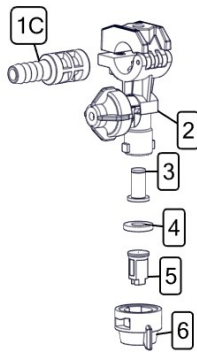

The AIXR TeeJet Flat Spray Tip offers the benefits of obtaining excellent drift resistance without compromising spray coverage. Tips producing very coarse droplets do minimize drift but do not provide the same surface coverage as tips that produce smaller droplets. In some applications, inadequate coverage decreases the effectiveness of the applied chemicals.

AIXR Features and Benefits

- 110° wide, tapered flat spray angle with air induction technology for better drift management
- Made of 2-piece UHMWPE polymer construction which provides excellent chemical resistance, including acids, as well as exceptional wear life
- Compact size to prevent tip damage
- Removable pre-orifice
- Excellent for systemic products and drift management

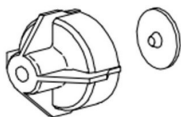

Check Valve Cap: 5046113
Diaphragm: 5063132

Ref. #	Part #	Description	Qty
1A	5002514	Single 1/2" Dry Boom Nozzle Adapter	1
1B	5002513	Double 1/2" Dry Boom Nozzle Adapter	1
1C	5002514	Single 1/2" Dry Boom Nozzle Adapter	1
2	5056125	QJ17560A-1/2 1/2" Wet Boom QJ Nozzle Body	3
3	5116019	Nozzle Strainer, Blue (50 Mesh)	3
4	5016157	Seat Washer - EPDM - QJ Caps	3
5	AIXR11003VP	Air-Induction XR Flat Spray Tip	3
6	5046217	Quick Cap - Blue	3
7	5034873	5/16-18 Low Profile Hex Nut (Not Shown)	3

MX517-QJD (5282865) Series Boom Component Breakdown & Parts List

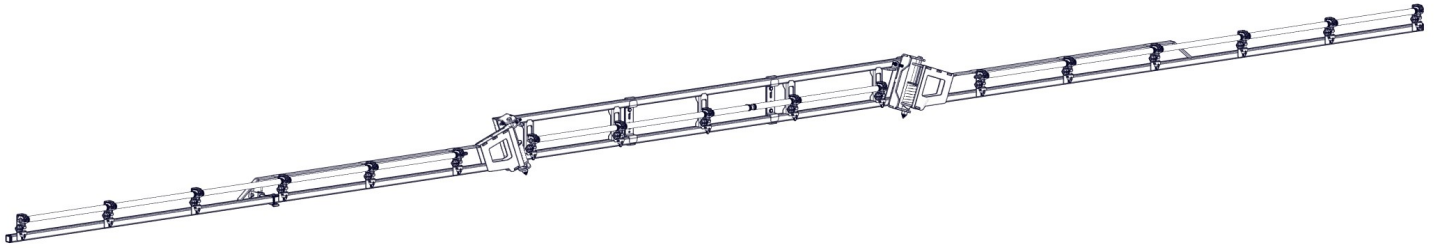

Ref. #	Part #	Description	Qty
1	5034637	5/16-18 x 1.25 Flng Hex Bolt	4
2	5051181-BLK	MX5 Saddle Mount Clamp	2
3	5282866-BLK	MX5 Center Section	1
4	5070313-BLK	MX5 Saddle Mount Base	2
5	5006389	5/16-18 Flng Top-Lock Hex Nut	5
6	5034544	3/8-16 x 2.50 Carriage Bolt	6
7	5282860	MX5 6-Nozzle Wing Assembly (LH)	1
7.1	5282867-BLK	MX5 Pivot Bracket (LH)	1
7.2	5101382-CNC	MX5 Pivot Pin	1
7.3	5282869-BLK	MX5 6-Nozzle Wing (LH)	1
7.4	5101383-CNC	Thrust Washer	1
7.5	5019763	Compression Spring, 4.50"	1
7.6	5006401	5/8-18 Nylock Hex Nut	1
7.7	5012025	3/16" Straight Drive Ball Check Grease Fitting	1
8	5282861	MX5 6-Nozzle Wing Assembly (RH)	1
8.1	5282868-BLK	MX5 Pivot Bracket (RH)	1
8.2	5101382-CNC	MX5 Pivot Pin	1
8.3	5282870-BLK	MX5 6-Nozzle Wing (RH)	1
8.4	5101383-CNC	Thrust Washer	1
8.5	5019763	Compression Spring, 4.50"	1
8.6	5006401	5/8-18 Nylock Hex Nut	1
8.7	5012025	3/16" Straight Drive Ball Check Grease Fitting	1
9	5034879	5/16-18 x 0.50 Phillips Truss Head Locking Screw	17
10	5282862	MX5 Center Boom Harness	1

Ref. #	Part #	Description	Qty
10.1	5086026	Poly Hose Tee, 1/2" HB	1
10.2	5020572	Hose, 1/2"-1 Brd. x 10"	2
10.3	5051114	Hose Clamp (1/2")	10
10.4	5002522	QJ17560A-1/2 w/AIXR11003 x 1/2 HB Tee	3
10.5	5020977	Hose, 1/2" (2SP) x 18-1/2" NBR & PVC	3
10.6	5002523	QJ17560A-1/2 w/AIXR11003 x 1/2 HB Single (LH)	1
10.7	5002524	QJ17560A-1/2 w/AIXR11003 x 1/2 HB Single (RH)	1
11	5282863	MX5 Boom Harness, 6-Nozzle Wing (LH)	1
11.1	5002522	QJ17560A-1/2 w/AIXR11003 x 1/2 HB Tee	5
11.2	5020977	Hose, 1/2" (2SP) x 18-1/2" NBR & PVC	5
11.3	5051114	Hose Clamp (1/2")	10
11.4	5002523	QJ17560A-1/2 w/AIXR11003 x 1/2 HB Single (LH)	1
12	5282864	MX5 Boom Harness, 6-Nozzle Wing (RH)	1
12.1	5002522	QJ17560A-1/2 w/AIXR11003 x 1/2 HB Tee	5
12.2	5020977	Hose, 1/2" (2SP) x 18-1/2" NBR & PVC	5
12.3	5051114	Hose Clamp (1/2")	10
12.4	5002524	QJ17560A-1/2 w/AIXR11003 x 1/2 HB Single (RH)	1
13	5034639	5/16-18 x 1.75 Flng Hex Bolt (Full Thread)	1
14	5282871-BLK	MX5 Travel Lock	1
15	5101260	5/16" x 1-3/4" Lynch Pin	1
16	5006362	3/8-16 Hex Jam Nut	4
17	5006345	3/8-16 Flng Top-Lock Hex Nut	4
18	5046448	1-1/4" Square Tube Cap	2

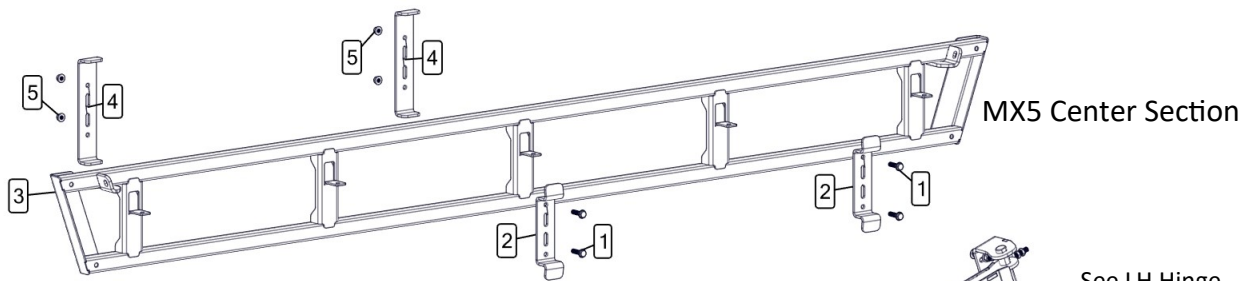

MX5 Center Section

MX517 6-Nozzle Wing Assembly (LH)

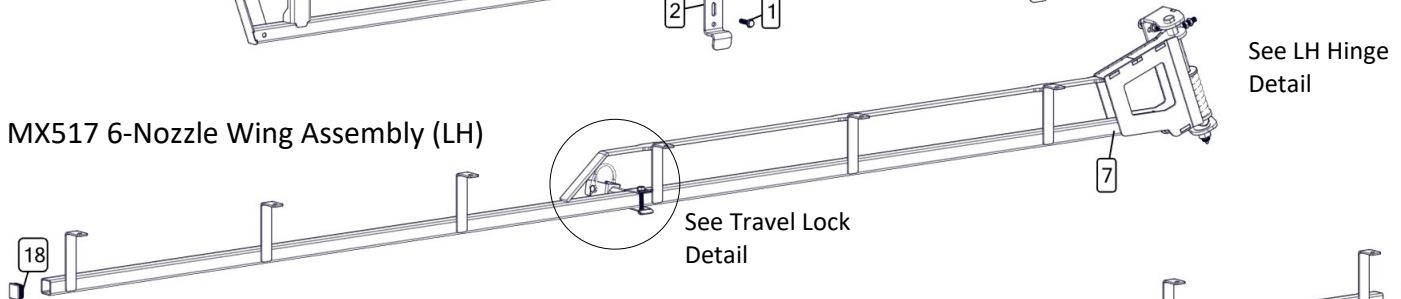

See LH Hinge Detail

See Travel Lock Detail

See RH Hinge Detail

MX517 6-Nozzle Wing Assembly (RH)

MX517-QJD (5282865) Series Boom Component Breakdown & Parts List

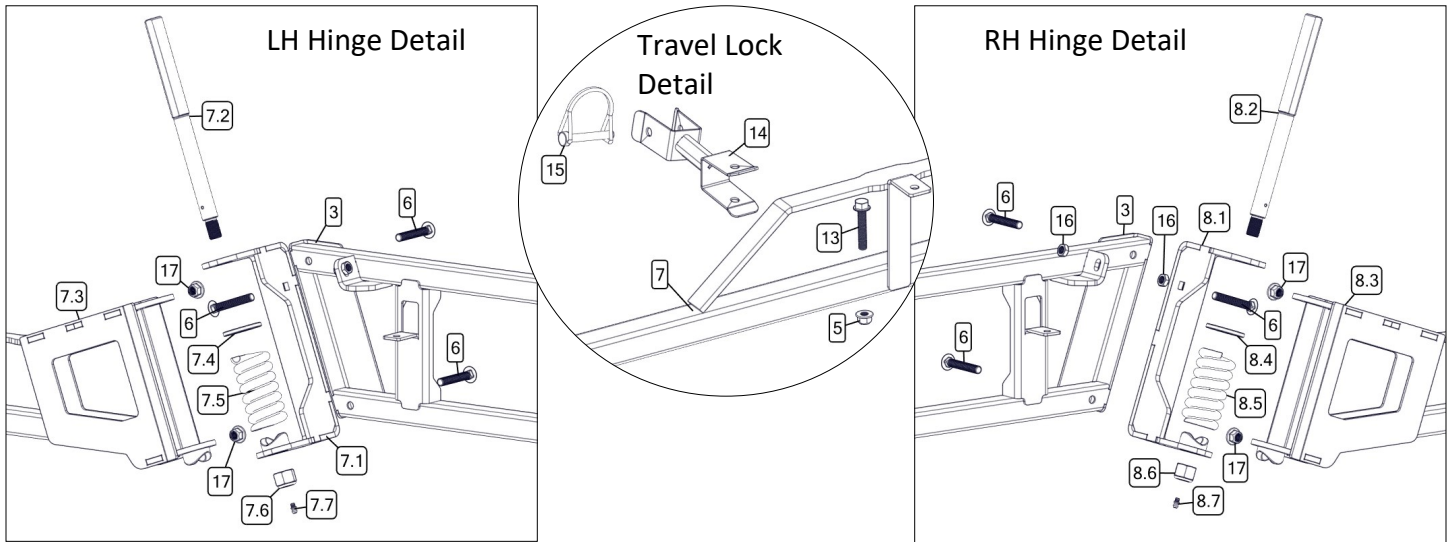

MX5 Center Boom Harness

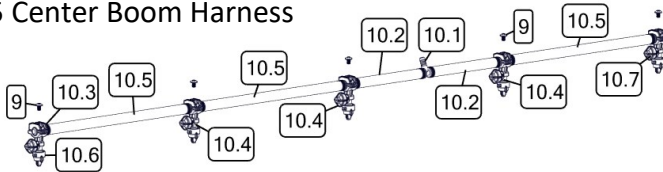

MX517 LH Boom Harness

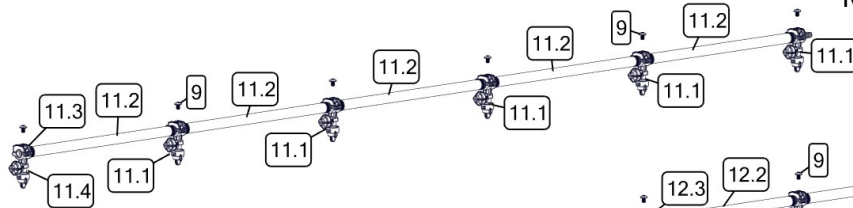

MX517 RH Boom Harness

5002524
RH Nozzle Assy

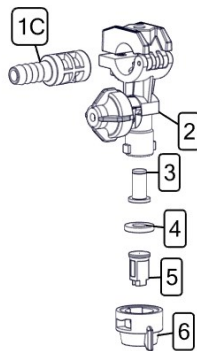

5002522
Nozzle Assy

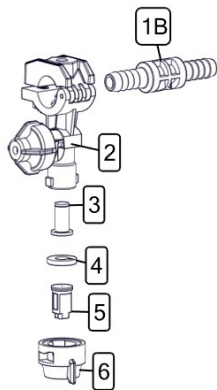

5002523
LH Nozzle Assy

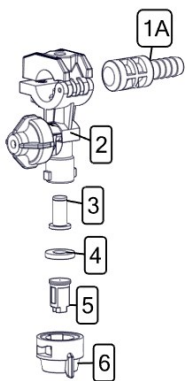

AIXR TeeJet Flat Spray Tip offers the benefits of obtaining excellent drift resistance without compromising spray coverage. Tips producing very coarse droplets do minimize drift but do not provide the same surface coverage as tips that produce smaller droplets. In some applications, inadequate coverage decreases effectiveness of the applied chemicals. AIXR Features and Benefits

- 110° wide, tapered flat spray angle with air induction technology for better drift management
- Made of 2-piece UHMWPE polymer construction which provides excellent chemical resistance, including acids, as well as exceptional wear life
- Compact size to prevent tip damage
- Removable pre-orifice
- Excellent for systemic products and drift management

Check Valve Cap: 5046113
Diaphragm: 5063132

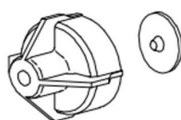

Ref. #	Part #	Description	Qty
1A	5002514	Single 1/2" Dry Boom Nozzle Adapter	1
1B	5002513	Double 1/2" Dry Boom Nozzle Adapter	1
1C	5002514	Single 1/2" Dry Boom Nozzle Adapter	1
2	5056125	QJ17560A-1/2 1/2" Wet Boom QJ Nozzle Body	3
3	5116019	Nozzle Strainer, Blue (50 Mesh)	3
4	5016157	Seat Washer - EPDM - QJ Caps	3
5	AIXR11003VP	Air-Induction XR Flat Spray Tip	3
6	5046217	Quick Cap - Blue	3
7	5034873	5/16-18 Low Profile Hex Nut (Not Shown)	3

Warranty Info

LIMITED WARRANTY FOR NEW Cimarron EQUIPMENT

WHO MAY USE THIS LIMITED WARRANTY. This limited warranty (the "Limited Warranty") is provided by Fimco, Inc. ("Cimarron Equipment") to the original purchaser ("you") of the Equipment (as defined below) from Cimarron Equipment or one of Cimarron Equipment's authorized dealers. This Limited Warranty does not apply to any subsequent owner or other transferee of the Equipment. THIS LIMITED WARRANTY GIVES YOU SPE-CIFIC LEGAL RIGHTS, AND YOU MAY ALSO HAVE OTHER RIGHTS WHICH VARY FROM STATE TO STATE.

WHAT THIS LIMITED WARRANTY COVERS AND FOR HOW LONG. Cimarron Equipment warrants that any registered new Equipment will be free from defects in material and workmanship for a period of **one (1) year** after delivery of the Equipment to you (the "Warranty Period"). The Warranty Period is not extended if Cimarron Equipment repairs or replaces the Equipment.

WHAT IS NOT COVERED BY THIS LIMITED WARRANTY. This Limited Warranty does not apply to: (1) used Equipment; (2) any Equipment that has been altered, changed, repaired or treated since its delivery to you, other than by Cimarron Equipment or its authorized dealers; (3) damage or depreciation due to normal wear and tear; (4) defects or damage due to failure to follow Cimarron Equipment's operator's manual, specifications or other written instructions, or improper storage, operation, maintenance, application or installation of parts; (5) defects or damage due to misuse, accident or neglect, "acts of God" or other events beyond Cimarron Equipment's reasonable control; (6) accessories, attachments, tools or parts that were not manufactured by Cimarron Equipment, whether or not sold or operated with the Equipment; or (7) rubber parts, such as tires, hoses and grommets.

HOW TO OBTAIN WARRANTY SERVICE. To obtain warranty service under this Limited Warranty, you must (1) provide written notice to Cimarron Equipment of the defect during the Warranty Period and within **thirty (30) days** after the defect becomes apparent or the repair becomes necessary, at the following address: Cimarron Equipment, 1000 Fimco Lane, North Sioux City, SD 57049; and (2) make the Equipment available to Cimarron Equipment or an authorized dealer within a reasonable period of time. For more information about this Limited Warranty, please call: **800-274-1025**

WHAT REMEDIES ARE AVAILABLE UNDER THIS LIMITED WARRANTY. If the conditions set forth above are fulfilled and the Equipment or any part thereof is found to be defective, Cimarron Equipment shall, at its own cost, and at its option, either repair or replace the defective Equipment or part. Cimarron Equipment will pay for shipping and handling fees to return the repaired or replacement Equipment or part to you.

LIMITATION OF IMPLIED WARRANTIES AND OTHER REMEDIES. THE REMEDIES DESCRIBED ABOVE ARE YOUR SOLE AND EXCLUSIVE REMEDIES, AND Cimarron EQUIPMENT'S SOLE LIABILITY, FOR ANY BREACH OF THIS LIMITED WARRANTY. TO THE EXTENT APPLICABLE, ANY IMPLIED WARRANTIES, INCLUDING, WITHOUT LIMITATION, THE IMPLIED WARRANTIES OF MERCHANTABILITY AND FITNESS FOR A PARTICULAR PURPOSE, SHALL BE LIMITED IN DURATION TO THE WARRANTY PERIOD, AND THE REMEDIES AVAILABLE FOR BREACH THEREOF SHALL BE LIMITED TO THE REMEDIES AVAILABLE UNDER THIS EXPRESS LIMITED WARRANTY. SOME STATES DO NOT ALLOW LIMITATIONS ON HOW LONG AN IMPLIED WARRANTY LASTS, SO THE ABOVE LIMITATION MAY NOT APPLY TO YOU. IN NO EVENT SHALL Cimarron EQUIPMENT'S LIABILITY UNDER THIS LIMITED WARRANTY EXCEED THE ACTUAL AMOUNT PAID BY YOU FOR THE DEFECTIVE EQUIPMENT, NOR SHALL Cimarron EQUIPMENT BE LIABLE, UNDER ANY CIRCUMSTANCES, FOR ANY CONSEQUENTIAL, INCIDENTAL, SPECIAL OR PUNITIVE DAMAGES OR LOSSES, WHETHER DIRECT OR INDIRECT. SOME STATES DO NOT ALLOW THE EXCLUSION OR LIMITATION OF INCIDENTAL OR CONSEQUENTIAL DAMAGES, SO THE ABOVE LIMITATION OR EXCLUSION MAY NOT APPLY TO YOU.

BAKERSFIELD, CA
4618 SACO RD, 93308
661.391.9081
Toll Free: 877.724.2236
F: 661.391.9085

COLUMBUS, NE
5834 23rd ST, 68601
402.564.4544
Toll Free: 800.274.1025
F: 402.564.0549

DOTHAN, AL
2401 FORRESTER RD, 36301
334.673.0580
Toll Free: 800.227.4098
F: 334.673.1974

FARGO, ND
4350 48th AVE N, 58102
701.280.2862
Toll Free: 800.373.4084
F: 701.293.0961

HOPKINSVILLE, KY
3303 PEMBROKE RD, 42240
270.886.0296
Toll Free: 800.637.7172
F: 270.885.7392

MANKATO, MN
907 SOUTHBEND AVE, 56001
507.377.6295
Toll Free: 800.722.9376
F: 507.388.4668

NEWTON, KS
7000 SCHABEN CT, 67114
316.283.4444
Toll Free: 800.394.7662
F: 316.293.4646

PASCO, WA
3035 TRAVEL PLAZA WAY, 99301
509.488.6631
Toll Free: 800.634.2026
F: 509.488.2927

TEMPE, AZ
8464 KYRENE RD, 85284
480.705.8047
Toll Free: 877.705-8047
F: 480.705.8048